



PDM Workbench

PDM Workbench Release 20.0 for Aras Innovator

User Manual

Version 1

Copyright

© 2005-2025 T-Systems International GmbH.

All rights reserved. Printed in Germany.

Contact

T-Systems International GmbH
Business Unit PLM
Fasanenweg 5
70771 Leinfelden-Echterdingen
Germany

<https://plm.t-systems.net/en-DE/pdm-workbench>

☎ +49 (0) 40 30600 5544

✉ +49 (0) 3915 80125688

mail : cmi_support@t-systems.com

Manual History

Version	Date	Version	Date	Version	Date
1.0	Apr 2005	3.6	Apr 2014	11.0	Nov 2019
2.0	Nov 2006	3.7	Oct 2014	12.0	May 2020
2.1	Nov 2007	3.8	Apr 2015	13.0	Nov 2020
2.2	Sep 2008	3.9	Oct 2015	14.0	May 2021
2.5	Sep 2010	4.0	Apr 2016	15.0	Jan 2022
3.0	Oct 2011	5.0	Oct 2016	16.0	Nov 2022
3.1	Feb 2012	6.0	Apr 2017	17.0	Jun 2023
3.2	Mar 2012	7.0	Oct 2017	18.0	May 2024
3.3	Oct 2012	8.0	May 2018	19.0	Mar 2025
3.4	Apr 2013	9.0	Dec 2018	20.0	Dec 2025
3.5	Oct 2013	10.0	May 2019		

This edition 20.0 of the manual obsoletes all previous editions.

Your Comments are Welcome

Please feel free to tell us your opinion; we are always interested in improving our publications. Mail your comments to:

T-Systems International GmbH
Business Unit PLM
Fasanenweg 5
70771 Leinfelden-Echterdingen
Germany

mail: cmi_support@t-systems.com

Preface

About this Manual

This manual describes the main functionality delivered by the PDM Workbench.

The functionality of the PDM Workbench as described in this manual uses Aras Innovator as backend PDM system for CATIA V5.

Other PDM systems might support the functionality of the PDM Workbench with their own types of objects. Layout of dialogs as well as object and relation types or classes might vary accordingly.

This manual is intended for end users of the PDM Workbench.

It assumes that the reader is familiar with the CATIA application and with Aras Innovator.

Related Documents

The following manuals contain information about installation, administration, usage, and customization of the PDM Workbench:

Manual Title	Version
<i>PDM Workbench Installation & Administration Manual</i>	20.0
<i>PDM Workbench User Manual</i>	20.0

Organization

This manual contains the following chapters:

Chapter 1 provides basic information about the PDM Workbench and describes some features of this application.

Chapter 2 describes the supported data models.

Chapter 3 describes the functionality which is implemented in the CATIA V5 workshop.

Chapter 4 describes the additional optional functionality.

Glossary contains the PDM Workbench terminology.

Trademarks

CATIA is a registered trademark of Dassault Systèmes.

Aras and Aras Innovator are registered trademarks of Aras Corporation.

Names of other products mentioned in this manual are used for identification purpose only and might be trademarks of their companies.

Table of Contents

CHAPTER 1	1
OVERVIEW	1
INTRODUCING PDM WORKBENCH	1
CHAPTER 2	3
SUPPORTED DATA MODELS	3
BOM PART STRUCTURE DATA MODEL	3
CAD DOCUMENT STRUCTURE DATA MODEL	4
CHAPTER 3	5
GETTING STARTED	5
LOGIN	5
QUERY.....	6
<i>“Select Date” Widget</i>	9
<i>Download Drawing Option</i>	9
<i>Automatically loading CATDrawings or linked CATParts</i>	10
<i>Additional Options for “Load with Links”</i>	11
<i>Filter Attribute Values are kept when changing the Type</i>	13
<i>Load of multiple Assemblies in the Query Dialog</i>	14
EXPAND SINGLE LEVEL	14
<i>“Current” and “Released” Expand Modes for “CAD Structure”</i>	15
EXPAND MULTIPLE LEVELS	19
EXPLICIT DISPLAY AND CONTROL OF “ASSAVED” AND “CURRENT” EXPAND RESOLUTIONS ..	20
DE-EXPAND	21
PROPERTIES	23
CLAIM	26
<i>Claim Part in PDM Workbench Window</i>	26
<i>Claim Object in Query Dialog</i>	27
<i>Claim Document in CATIA V5 Window</i>	27
UNCLAIM	28
<i>Unclaim Part in PDM Workbench Window</i>	28
<i>Unclaim Object in Query Dialog</i>	30
<i>Unclaim Document in CATIA V5 Window</i>	30
CLAIM ALL.....	31
<i>Claim All Parts in PDM Workbench Window</i>	31
<i>Claim All Documents in CATIA V5 Window</i>	33
UNCLAIM ALL.....	34
<i>Unclaim All Parts in PDM Workbench Window</i>	34
<i>Unclaim All Documents in CATIA V5 Window</i>	35
WARNING WHEN THE USER WANTS TO UNCLAIM MODIFIED FILES	36
PROMOTE	36
REVISE	38
UPDATE STRUCTURE RELATIONS	40
UPDATE PARENT RELATION	42
DELETE.....	43
CREATE NEW VERSION	44
DELETE NEWEST VERSION	45
ONLY ONE NEW GENERATION OF A CAD DOCUMENT PER “CLAIM” ACTION	47
UNLINK AND DELETE NEWEST VERSION	47
OPEN FILE	49
OPEN FILE TEMPORARY.....	51
LOAD	54
<i>Additional Options for “Loading PDM Structures”</i>	56
LOAD SUBSTRUCTURES IN CONTEXT	57

<i>BOM Part Structure Data Model</i>	57
<i>CAD Document Structure Data Model</i>	60
ADD TEMP.....	63
DUPLICATE.....	66
IMPROVED “PARTS IN SESSION” FUNCTIONALITY IN CAD DOCUMENT STRUCTURE DATA MODEL.....	70
Duplicate Structure.....	72
<i>Variant A (only available in CAD Document Structure Data Model)</i>	73
<i>Variant B</i>	81
<i>Variant B - Duplicate Structure enhancements</i>	87
CREATE RELATION BETWEEN WINDOWS	88
CREATE CAD IN PARENT	90
UPDATE	92
<i>Option to block the Update if linked File is not saved</i>	94
<i>Option: “Update to PDM” Dialog only shown if new Documents to be created exist</i>	94
ADD NEWLY CREATED AND UPDATED PART OR CAD ITEMS TO EXISTING ITEMS	94
DENY CREATE OF CAD AT TOP-LEVEL STRUCTURE IN BOM PART STRUCTURE DATA MODEL	96
SELECT TYPE OF ADDITIONAL PARTS IN CAD DOCUMENT STRUCTURE DATA MODEL.....	97
<i>Non-BOM CATParts and CATProducts</i>	99
<i>Attach additional non-BOM CATParts to Part</i>	102
RECONNECT AT UPDATE	103
<i>Import Product Structure</i>	104
<i>Import CATDrawing</i>	104
SHOW PDM STRUCTURE	106
REFRESH PDM STRUCTURE	107
<i>“Refresh” is active in the Main Toolbar</i>	108
PDM STATUS INFORMATION IN THE CATIA TREE.....	109
HIGHLIGHT PDM NODES.....	109
HIGHLIGHT CATIA NODES	110
OPEN IN NEW WINDOW.....	111
COMPARING PDM STRUCTURE TREES	112
SELECTING NODES IN THE PDM STRUCTURE WINDOW	113
FORCE LOAD CATPART.....	115
INSERT FROM PDM.....	115
<i>Insert from Aras Innovator keep “PDM Query” Dialog</i>	118
REPLACE FROM PDM	118
SYNCHRONIZE CAD STRUCTURE TO BOM	121
ATTRIBUTE MAPPING	124
<i>CATPart and CATProduct</i>	124
<i>CATDrawing</i>	136
<i>Inertia attributes mapping</i>	139
<i>PDM to CAD Attribute Mapping only for CATIA Files claimed by the User</i>	141
<i>Allow mapping of Part and CAD Property to the same CATIA Standard Attribute</i> ..	141
INTERNAL CATIA INFORMATION CAN BE WRITTEN TO USER-DEFINED CATIA PROPERTIES.	141
CREATE CAD DOCUMENT AND PART WITH TEMPLATES	143
MANAGE CATIA TEMPLATES IN ARAS INNOVATOR	145
TEMPLATE FILE SUPPORT FOR “CREATE PART” WITH TEMPLATES DEPENDING ON THE PART TYPE.....	146
<i>Usage</i>	147
STANDARD PART SUPPORT.....	149
<i>“Standard Part” Functionality for BOM Part Structure Data Model</i>	150
<i>“Standard Part” Functionality for CAD Document Structure Data Model</i>	150
CATIA DESIGN TABLE SUPPORT.....	156
ARCHIVE SUPPORT	158
CATIA CATALOG SUPPORT	159
<i>Create Catalog</i>	160
<i>Update Catalog</i>	161
<i>Open Catalog Browser</i>	162
<i>Open Catalog for special Usage</i>	163
<i>Support floating Content in Catalog</i>	164
<i>Configurable Catalog Keywords</i>	164

CATPROCESS FILE SUPPORT	165
CONFIGURABLE CATIA COMPONENT SUPPORT	168
ELECTRICAL/TUBING SUPPORT	168
ADDITIONAL REP TYPES.....	170
SUPPORT GENERIC SHAPE REPRESENTATIONS	171
CATIA DOCUMENTS ARE SET TO READ-ONLY IF CORRESPONDING PDM NODE IS NOT MODIFIABLE	171
CHECK WHETHER CATIA STRUCTURE IS VALID BEFORE UPDATE	172
THUMBNAILS	172
LINK MANAGEMENT.....	172
BASIC DRAWING LINK SUPPORT	174
CATDRAWING: LOADING REFERENCED DATA AS “CURRENT”	176
BASIC MULTI-MODEL LINK SUPPORT	179
SUPPORT FOR RELATING A NEW CATIA FILE TO AN EXISTING PART	181
DELETE RELATION.....	182
DELETE RELATIONS OF NON-LOADED INSTANCES	183
BOUNDING BOX MANAGEMENT / “SHOW NEIGHBOR” FUNCTIONALITY	184
AUTOMATIC PART CREATION IN CAD DOCUMENT STRUCTURE DATA MODEL.....	188
SUPPORT FOR THE NEW CAD STRUCTURE INSTANCE HANDLING INTRODUCED IN ARAS INNOVATOR 9.4 AND 10.0.....	189
“CAD IS MASTER FOR INSTANCES” FUNCTIONALITY.....	191
CHECK FOR CAD DOCUMENT CATIA RELEASE AT “UPDATE” PROCESS.....	191
LOCAL WORKSPACE INFORMATION.....	191
CONFIGURATION OF BOM PART STRUCTURE.....	192
CHECK CAD LINKS.....	197
DISPLAYING PDM STRUCTURE INSTANCES AS SEPARATE NODES	198
SAVING PDM SESSION INFORMATION.....	198
ALLOW DEACTIVATED CATPRODUCT AND CATPART INSTANCES	203
SETTING CONFIGURATION INFORMATION ON STRUCTURE RELATIONS.....	204
RELEASED CACHE MODE	205
<i>Set the Cache File Download Mode in User Settings</i>	205
<i>Command “Get original Geometry”</i>	207
“OPEN IN CATIA” FROM THE ARAS INNOVATOR CLIENT	207
“OPEN IN CATIA” FROM THE ARAS INNOVATOR CLIENT WITH CONSTRUCTION SPACE	210
<i>Configuration</i>	211
<i>Access Rights</i>	211
<i>Usage</i>	211
“OPEN IN ARAS” FROM CATIA V5 CLIENT.....	213
CREATE DRAWING CAD DOCUMENT: AUTOMATICALLY SELECT LOADED PART IN SESSION IF A SINGLE LINK EXISTS	213
MANAGE CONTEXT PRODUCTS.....	215
OPTIONS.....	215
<i>Query Dialog</i>	216
<i>PDM Relations</i>	217
<i>CATDrawings</i>	218
<i>Loading related Files</i>	218
<i>Loading PDM Structures</i>	218
<i>Cache File Download Mode</i>	218
<i>Expand Neighborhood</i>	218
<i>Copy Position</i>	218
PDM SESSION CONFIGURATION.....	218
LOGOUT	218
CHAPTER 4.....	221
ADDITIONAL OPTIONAL FUNCTIONALITY	221
COPY ELEMENT ATTRIBUTES.....	221
AUTONAME SUPPORT USING ARAS INNOVATOR SEQUENCE ITEMS.....	223
POSSIBILITY TO CALL A SERVER METHOD FOR A PDM ITEM	224
GLOSSARY	227

Table of Figures

PICTURE 1: PDM WORKBENCH WORKSHOP IN CATIA V5	1
PICTURE 2: PDM STRUCTURE IN THE BOM PART STRUCTURE DATA MODEL	3
PICTURE 3: PDM STRUCTURE IN THE CAD DOCUMENT STRUCTURE DATA MODEL.....	4
PICTURE 4: THE PDM WORKBENCH TOOLBAR BEFORE THE LOGIN.....	5
PICTURE 5: "LOGIN" DIALOG.....	5
PICTURE 6: THE PDM WORKBENCH TOOLBAR AFTER THE LOGIN	6
PICTURE 7: THE PDM WORKBENCH CONTEXT COMMANDS TOOLBAR	6
PICTURE 8: "PDM QUERY" DIALOG	7
PICTURE 9: "PDM QUERY" DIALOG – ENTER QUERY CRITERIA.....	7
PICTURE 10: "PDM QUERY" DIALOG – FOUND OBJECTS	8
PICTURE 11: "PDM QUERY" DIALOG – ACTION "OPEN IN NEW PDM WINDOW"	8
PICTURE 12: QUERY RESULT IN PDM STRUCTURE WINDOW.....	8
PICTURE 13: DATE FIELD AND DATE SELECTION DIALOG.....	9
PICTURE 14: DATE FIELD FILLED AFTER THE "DATE SELECTION DIALOG"	9
PICTURE 15: CATDRAWING DOCUMENTS RELATED TO PART ITEM.....	9
PICTURE 16: "QUERY" RESULT DIALOG WITH "DOWNLOAD CATDRAWING RELATED TO BOM PART" CHECK BOX.....	10
PICTURE 17: CATDRAWINGS OPENED IN CATIA SESSION.....	10
PICTURE 18: "LOAD WITH LINKS" AND "LOAD WITH DRAWINGS" CHECK BOXES	11
PICTURE 19: ACTIVATE "LOAD WITH LINKS"	11
PICTURE 20: ADDITIONAL OPTIONS FOR "LOAD WITH LINKS"	12
PICTURE 21: DOCUMENT NUMBER QUERY VALUE FOR CAD DOCUMENTS.....	13
PICTURE 22: SWITCHING TO PART ITEMS.....	13
PICTURE 23: PART NUMBER VALUE IS TAKEN FROM CAD DOCUMENT NUMBER VALUE.....	14
PICTURE 24: ACTION "EXPAND SINGLE LEVEL"	14
PICTURE 25: RESULT OF EXPAND SINGLE LEVEL.....	15
PICTURE 26: RESULT OF EXPAND SINGLE LEVEL WITHOUT RELATIONS	15
PICTURE 27: THREE CAD STRUCTURE EXPAND MODES.....	16
PICTURE 28: GENERATION 1 OF CATPART.....	16
PICTURE 29: CAD STRUCTURE CONTAINING GENERATION 1 OF CATPART	17
PICTURE 30: WARNING ABOUT DIFFERENT EXPAND RESOLUTION	17
PICTURE 31: CAD STRUCTURE EXPANDED AS "CURRENT"	18
PICTURE 32: CATIA STRUCTURE CONTAINING THE LATEST GENERATIONS OF THE CATIA DOCUMENTS	18
PICTURE 33: CONFIRM "UPDATE" ACTION	19
PICTURE 34: ACTION "EXPAND MULTIPLE LEVELS".....	19
PICTURE 35: RESULT OF EXPAND MULTIPLE LEVELS	20
PICTURE 36: CAD STRUCTURE EXPANDED AS "CURRENT"	20
PICTURE 37: CAD STRUCTURE EXPANDED "ASSAVED"	21
PICTURE 38: "UPDATE TO PDM" DIALOG WITH "UPDATE TO CURRENT" INFORMATION.....	21
PICTURE 39: PDM STRUCTURE BEFORE THE DE-EXPAND	22
PICTURE 40: ACTION "DE-EXPAND".....	22
PICTURE 41: PDM STRUCTURE AFTER THE DE-EXPAND.....	23
PICTURE 42: ACTION "PROPERTIES".....	23
PICTURE 43: "PROPERTIES" DIALOG – TAB "PROPERTIES"	24
PICTURE 44: "PROPERTIES" DIALOG – TAB "UPDATE ITEM"	25
PICTURE 45: ACTION "CLAIM"	26
PICTURE 46: OBJECT IS CLAIMED	26
PICTURE 47: CLAIMED OBJECT.....	27
PICTURE 48: ACTION "CLAIM" IN THE QUERY RESULT LIST.....	27
PICTURE 49: ACTION "CLAIM" IN THE CATIA V5 WINDOW.....	28
PICTURE 50: ACTION "UNCLAIM"	29
PICTURE 51: OBJECT IS UNCLAIMED.....	29
PICTURE 52: UNCLAIMED OBJECT	30
PICTURE 53: ACTION "UNCLAIM" IN THE QUERY RESULT LIST.....	30
PICTURE 54: ACTION "UNCLAIM" IN THE CATIA V5 WINDOW.....	31

PICTURE 55: ACTION "CLAIM ALL"	32
PICTURE 56: CONFIRM THE "CLAIM ALL" ACTION	32
PICTURE 57: OBJECTS ARE CLAIMED	32
PICTURE 58: CLAIMED OBJECTS	33
PICTURE 59: ACTION "CLAIM ALL" IN THE CATIA V5 WINDOW	33
PICTURE 60: ACTION "UNCLAIM ALL"	34
PICTURE 61: CONFIRM THE "UNCLAIM ALL" ACTION	34
PICTURE 62: OBJECTS ARE UNCLAIMED	35
PICTURE 63: UNCLAIMED OBJECTS	35
PICTURE 64: ACTION "UNCLAIM ALL" IN THE CATIA V5 WINDOW	36
PICTURE 65: WARNING DIALOG AT UNCLAIM	36
PICTURE 66: ACTION "PROMOTE"	37
PICTURE 67: CONFIRM THE "PROMOTE" ACTION	38
PICTURE 68: OBJECT IS PROMOTED	38
PICTURE 69: ACTION "REVISE"	39
PICTURE 70: CONFIRM THE "REVISE" ACTION	39
PICTURE 71: OBJECT IS REVISED	40
PICTURE 72: ACTION "UPDATE STRUCTURE RELATIONS"	41
PICTURE 73: STRUCTURE RELATIONS ARE UPDATED	41
PICTURE 74: ACTION "UPDATE PARENT RELATION"	42
PICTURE 75: ACTION "UPDATE PARENT RELATION" – SELECT VERSION	42
PICTURE 76: PARENT RELATION IS UPDATED	43
PICTURE 77: UPDATED STRUCTURE RELATION	43
PICTURE 78: ACTION "DELETE"	44
PICTURE 79: CONFIRM THE "DELETE" ACTION	44
PICTURE 80: OBJECTS ARE DELETED	44
PICTURE 81: ACTION "CREATE NEW VERSION"	45
PICTURE 82: ACTION "DELETE NEWEST VERSION"	46
PICTURE 83: CONFIRM THE "DELETE NEWEST VERSION" ACTION	46
PICTURE 84: NEWEST GENERATION OBJECT IS DELETED	47
PICTURE 85: RE-EXPAND OF THE DOCUMENT	47
PICTURE 86: ACTION "UNLINK AND DELETE NEWEST VERSION"	48
PICTURE 87: CONFIRM THE "UNLINK AND DELETE NEWEST VERSION" ACTION	48
PICTURE 88: NEWEST GENERATION OBJECT IS UNLINKED AND DELETED	49
PICTURE 89: ACTION "OPEN FILE"	50
PICTURE 90: OPEN FILE – PROGRESS BAR	50
PICTURE 91: SPLIT WINDOW AFTER OPEN FILE – PDM WORKBENCH NODE AND CATIA DRAWING	51
PICTURE 92: ACTION "OPEN FILE"	51
PICTURE 93: CURRENT FILE	52
PICTURE 94: ACTION "OPEN FILE TEMPORARY"	53
PICTURE 95: TEMPORARILY OPENED FILE	54
PICTURE 96: ACTION "LOAD"	55
PICTURE 97: LOAD - PROGRESS BAR	55
PICTURE 98: SPLIT WINDOW AFTER LOAD – PDM WORKBENCH AND CATIA V5 NODES	56
PICTURE 99: ADDITIONAL OPTIONS FOR "LOADING PDM STRUCTURES"	57
PICTURE 100: ACTION "LOAD IN CONTEXT" – WITH SOME STRUCTURE NODES SELECTED	58
PICTURE 101: CONFIRM THE "LOAD IN CONTEXT" ACTION	59
PICTURE 102: "LOAD IN CONTEXT" – SELECTED OBJECTS LOADED TO CATIA	60
PICTURE 103: ACTION "LOAD IN CONTEXT" – WITH SOME STRUCTURE NODES SELECTED	61
PICTURE 104: CONFIRM THE "LOAD IN CONTEXT" ACTION	61
PICTURE 105: "LOAD IN CONTEXT" – REDUCED PDM STRUCTURE IN PDM STRUCTURE WINDOW	62
PICTURE 106: "LOAD IN CONTEXT" – REDUCED STRUCTURE LOADED TO CATIA	62
PICTURE 107: ACTION "LOAD"	63
PICTURE 108: LOADED GEOMETRY FOR REVISION "B"	64
PICTURE 109: ACTION "ADD TEMP"	65
PICTURE 110: LOADED GEOMETRY FOR REVISION "A"	66
PICTURE 111: ACTION "DUPLICATE"	67
PICTURE 112: "PDM CREATE" DIALOG FOR DUPLICATE	68
PICTURE 113: FILLED "PDM CREATE" DIALOG FOR DUPLICATE	69
PICTURE 114: DUPLICATED CATPRODUCT OBJECT	70

PICTURE 115: DROPDOWN LIST CONTAINING RELATED PARTS.....	70
PICTURE 116: DIALOG WHERE A NEW PART IS CREATED	71
PICTURE 117: DROPDOWN LIST CONTAINING NEWLY CREATED PART.....	71
PICTURE 118: DIALOG WITH NEWLY CREATED PART SELECTED.....	72
PICTURE 119: DIALOG WITH NEWLY CREATED PART SELECTED.....	72
PICTURE 120: STRUCTURE TO BE DUPLICATED	73
PICTURE 121: PRE-SELECTED LIST OF DOCUMENTS	74
PICTURE 122: DOCUMENT LIST WITH UNCHECKED DOCUMENTS	75
PICTURE 123: SELECTING A SUBSTRUCTURE TO DUPLICATE	76
PICTURE 124: EXAMPLE WITH SMALL SUBSTRUCTURE	76
PICTURE 125: CHANGED KEY ATTRIBUTE	77
PICTURE 126: STRUCTURE BEING DUPLICATED.....	77
PICTURE 127: DUPLICATE STRUCTURE – PROGRESS BAR.....	78
PICTURE 128: EXISTING PDM STRUCTURE CONTAINING OLD SUBSTRUCTURE	78
PICTURE 129: CATIA STRUCTURE CONTAINING NEW SUBSTRUCTURE.....	79
PICTURE 130: UPDATE WITH NEW SUBSTRUCTURE.....	79
PICTURE 131: UPDATE HAS CHANGED THE STRUCTURE TO THE NEW SUBSTRUCTURE	80
PICTURE 132: EXISTING PDM STRUCTURE CONTAINING NEW SUBSTRUCTURE.....	80
PICTURE 133: STRUCTURE TO BE DUPLICATED	81
PICTURE 134: DUPLICATE STRUCTURE – PRE-SELECTED LIST OF DOCUMENTS	82
PICTURE 135: DUPLICATE STRUCTURE – SELECTED NODE	82
PICTURE 136: DUPLICATE STRUCTURE – UNCHECK SELECTED NODE	82
PICTURE 137: DUPLICATE STRUCTURE – DOCUMENT LIST WITH UNCHECKED DOCUMENTS	83
PICTURE 138: DUPLICATE STRUCTURE – FILL NAMING RULE	83
PICTURE 139: DUPLICATE STRUCTURE – NEW TARGET NAMES.....	83
PICTURE 140: DUPLICATE STRUCTURE – FILL SINGLE TARGET NAME	84
PICTURE 141: DUPLICATE STRUCTURE – FILLED SINGLE TARGET NAME	84
PICTURE 142: DUPLICATED STRUCTURE IN CATIA.....	84
PICTURE 143: SYNCHRONIZE THE DUPLICATED STRUCTURE	85
PICTURE 144: SELECTING A SUBSTRUCTURE TO DUPLICATE	85
PICTURE 145: EXAMPLE WITH SMALL SUBSTRUCTURE	86
PICTURE 146: EXAMPLE WITH SMALL SUBSTRUCTURE – FILLED TARGET NAMES	86
PICTURE 147: DUPLICATED SUBSTRUCTURE IN NEW CATIA WINDOW.....	87
PICTURE 148: NEW FUNCTION IN THE “DUPLICATE STRUCTURE” DIALOG	87
PICTURE 149: “DUPLICATE STRUCTURE” DIALOG, HIDE “CATIA DISPLAY” COLUMN	88
PICTURE 150: ACTION “COPY” BETWEEN WINDOWS	88
PICTURE 151: ACTION “PASTE” BETWEEN WINDOWS	89
PICTURE 152: SELECT THE NEW RELATION	89
PICTURE 153: PDM STRUCTURE WITH INSERTED OBJECT.....	89
PICTURE 154: ACTION “PDM CREATE IN CONTEXT”.....	90
PICTURE 155: CREATE IN CONTEXT – SELECT OBJECT TYPE	90
PICTURE 156: ACTION “CREATE”	91
PICTURE 157: CREATED OBJECT.....	91
PICTURE 158: UPDATE RESULT WINDOW FOR CREATE OBJECT.....	91
PICTURE 159: UPDATE WINDOW FOR CREATE RELATION.....	91
PICTURE 160: UPDATE RESULT WINDOW FOR CREATE RELATION	92
PICTURE 161: CONFIRM THE “UPDATE” (WITH CREATE) ACTION.....	92
PICTURE 162: UPDATE – PROGRESS BARS	93
PICTURE 163: OBJECTS ARE UPDATED (WITH CREATE)	93
PICTURE 164: CONFIRM THE “UPDATE” ACTION	93
PICTURE 165: OBJECTS ARE UPDATED	94
PICTURE 166: INFORMATION ABOUT CATPARTS TO BE UPDATED.....	94
PICTURE 167: FOLDER LIST	95
PICTURE 168: EXPANDING “IS IN FOLDERS” IN THE PDM STRUCTURE WINDOW.....	95
PICTURE 169: EXPANDING “FOLDER ITEMS” IN THE PDM STRUCTURE WINDOW	96
PICTURE 170: EXPANDED FOLDER ITEMS IN THE PDM STRUCTURE WINDOW	96
PICTURE 171: NON-CAD TOP-LEVEL STRUCTURE WITH ON THE FLY CREATED CATPRODUCTS	97
PICTURE 172: UPDATE NON-CAD TOP-LEVEL STRUCTURE -> RESULT SKIPPED	97
PICTURE 173: ACTION “SET PDM TYPE TO”	98
PICTURE 174: “UPDATE TO PDM” DIALOG FOR CATPRODUCT STRUCTURE.....	98
PICTURE 175: “UPDATE TO PDM” DIALOG FOR CATPART DOCUMENT	99
PICTURE 176: SETTING A CATPRODUCT TO THE NON-BOM TYPE	100

PICTURE 177: SETTING A CATPART TO THE NON-BOM TYPE.....	100
PICTURE 178: "UPDATE TO PDM" DIALOG WITH NON-BOM PART ITEMS	101
PICTURE 179: RESULTING PDM STRUCTURE.....	101
PICTURE 180: SELECT PDM TYPE OF CATPART	102
PICTURE 181: UPDATE NON-BOM FILE IN BOM PART STRUCTURE DATA MODEL.....	102
PICTURE 182: RELATE ACTIVE NON-BOM FILE TO PART	103
PICTURE 183: "PDM WORKBENCH OPTIONS" DIALOG "OPEN LINKED DOCUMENTS IN OWN WINDOW"	103
PICTURE 184: "UPDATE TO PDM" DIALOG WITH "IMPORT WITH RECONNECT" BUTTON.....	104
PICTURE 185: MESSAGES ABOUT RECONNECTED ITEMS.....	104
PICTURE 186: OPENING REFERENCED 3D GEOMETRY FILES	105
PICTURE 187: RECONNECT REFERENCED PRODUCT STRUCTURE.....	105
PICTURE 188: UPDATING THE CURRENT SHEET.....	106
PICTURE 189: PDM STRUCTURE FOR GEOMETRY	106
PICTURE 190: PDM STRUCTURE AND GEOMETRY IN CATIA V5.....	107
PICTURE 191: MAKING CHANGES IN THE GEOMETRY	108
PICTURE 192: REFRESHED PDM STRUCTURE	108
PICTURE 193: PDM STATUS INFORMATION IN THE CATIA TREE.....	109
PICTURE 194: ACTION "HIGHLIGHT PDM NODES"	109
PICTURE 195: HIGHLIGHTED NODES IN PDM STRUCTURE.....	110
PICTURE 196: ACTION "HIGHLIGHT CATIA NODES"	110
PICTURE 197: HIGHLIGHTED NODES IN CATIA GEOMETRY	111
PICTURE 198: ACTION "OPEN IN NEW WINDOW"	112
PICTURE 199: SELECTED OBJECTS IN THE NEW WINDOW	112
PICTURE 200: TWO CAD DOCUMENT STRUCTURES TO BE COMPARED	113
PICTURE 201: WINDOW CONTAINING THE DIFFERENCES BETWEEN THE TWO STRUCTURES	113
PICTURE 202: "SELECT NODES" DIALOG.....	114
PICTURE 203: SELECTED NODES.....	114
PICTURE 204: ACTION "FORCE LOAD CATPART".....	115
PICTURE 205: ACTION "INSERT PDM NODE"	116
PICTURE 206: INSERT PDM NODE – "PDM QUERY" DIALOG TYPE SELECTION.....	116
PICTURE 207: INSERT PDM NODE – QUERY RESULT.....	117
PICTURE 208: ITEM INSERTED IN EXISTING STRUCTURE	117
PICTURE 209: "IMPACTS ON REPLACE" STANDARD CATIA DIALOG.....	118
PICTURE 210: CONSTRAINTS DESTROYED BY "REPLACE" OPERATION	119
PICTURE 211: ACTION "REPLACE NODE"	120
PICTURE 212: SELECT REPLACING NODE	120
PICTURE 213: "REPLACE ALL INSTANCES" PROMPT	121
PICTURE 214: ACTION "SYNCHRONIZE TO BOM"	122
PICTURE 215: ACTION "SYNCHRONIZE TO BOM" – CONFIRMATION.....	122
PICTURE 216: CREATED OR UPDATED PDM STRUCTURE.....	123
PICTURE 217: "SYNCHRONIZE IN BOM" IN ARAS INNOVATOR WEB CLIENT.....	123
PICTURE 218: PART MAPPING – STANDARD ATTRIBUTES IN THE "PROPERTIES" DIALOG.....	124
PICTURE 219: PART MAPPING – CONFIGURATION OF STANDARD ATTRIBUTES IN ARAS INNOVATOR	125
PICTURE 220: PART MAPPING – PRE-FILLED "PDM CREATE" DIALOG.....	126
PICTURE 221: PART MAPPING – STANDARD ATTRIBUTES IN THE "PROPERTIES" DIALOG OF THE PDM NODE.....	127
PICTURE 222: PART MAPPING – STANDARD ATTRIBUTES IN ARAS INNOVATOR.....	128
PICTURE 223: CAD DOCUMENT MAPPING – STANDARD ATTRIBUTES IN THE "PROPERTIES" DIALOG	129
PICTURE 224: CAD DOCUMENT MAPPING – CONFIGURATION OF STANDARD ATTRIBUTES IN ARAS INNOVATOR	130
PICTURE 225: CAD DOCUMENT MAPPING – PRE-FILLED "PDM CREATE" DIALOG	131
PICTURE 226: CAD DOCUMENT MAPPING – STANDARD ATTRIBUTES IN THE "PROPERTIES" DIALOG OF THE PDM NODE	131
PICTURE 227: CAD DOCUMENT MAPPING – STANDARD ATTRIBUTES IN ARAS INNOVATOR	132
PICTURE 228: CONFIGURATION OF USER-DEFINED ATTRIBUTES IN ARAS INNOVATOR.....	132
PICTURE 229: USER-DEFINED ATTRIBUTES MAPPING – STANDARD ATTRIBUTES IN THE "PROPERTIES" DIALOG.....	133
PICTURE 230: USER-DEFINED ATTRIBUTES MAPPING – PRE-FILLED "PDM CREATE" DIALOG..	134

PICTURE 231: USER-DEFINED ATTRIBUTES MAPPING – STANDARD ATTRIBUTES IN THE “PROPERTIES” DIALOG OF THE PDM NODE	135
PICTURE 232: USER-DEFINED ATTRIBUTES MAPPING – STANDARD ATTRIBUTES IN ARAS INNOVATOR	135
PICTURE 233: USER-DEFINED ATTRIBUTES IN THE “PROPERTIES” DIALOG.	136
PICTURE 234: DRAWING ATTRIBUTES MAPPING – CONFIGURATION OF DRAWING ATTRIBUTES IN ARAS INNOVATOR	137
PICTURE 235: DRAWING ATTRIBUTES MAPPING – CATDRAWING ATTRIBUTE MAPPING	137
PICTURE 236: DRAWING ATTRIBUTES MAPPING – MODIFY DRAWING ATTRIBUTE VALUE	138
PICTURE 237: DRAWING ATTRIBUTES MAPPING – MODIFIED DRAWING ATTRIBUTE VALUE	138
PICTURE 238: DRAWING ATTRIBUTES MAPPING – MODIFIED PDM ATTRIBUTE VALUE	138
PICTURE 239: DRAWING ATTRIBUTES MAPPING – PDM ATTRIBUTE VALUE MODIFIED FROM ARAS INNOVATOR	139
PICTURE 240: DRAWING ATTRIBUTES MAPPING – DRAWING ATTRIBUTE VALUE CHANGED TO PDM ATTRIBUTE VALUE	139
PICTURE 241: SAMPLE MATERIAL DEFINITION IN CATIA	140
PICTURE 242: CATIA TREE AND INERTIA PROPERTIES	140
PICTURE 243: INERTIA PROPERTIES MAPPED TO ARAS INNOVATOR.....	141
PICTURE 244: MAPPING OF CATIA ATTRIBUTE NOMENCLATURE FROM CAD AND PART.....	141
PICTURE 245: USER-DEFINED ATTRIBUTES WITH INTERNAL CATIA INFORMATION IN “PROPERTIES” DIALOG.....	142
PICTURE 246: CONFIGURATION OF USER-DEFINED ATTRIBUTES IN ARAS INNOVATOR.....	143
PICTURE 247: SELECT A PDM TYPE FOR THE “PDM CREATE” DIALOG.....	143
PICTURE 248: “PDM CREATE” DIALOG FOR CATPART – SELECT TEMPLATE.....	144
PICTURE 249: “PDM CREATE” DIALOG FOR CATPART IN BOM PART STRUCTURE DATA MODEL	144
PICTURE 250: “PDM CREATE” DIALOG FOR CATPART IN CAD DOCUMENT STRUCTURE DATA MODEL	144
PICTURE 251: CREATED PART	145
PICTURE 252: “TEMPLATE FILE” FUNCTIONALITY – CREATING A CATPART.....	145
PICTURE 253: “TEMPLATE FILE” FUNCTIONALITY – SELECTING A TEMPLATE FILE.....	146
PICTURE 254: “TEMPLATE FILE” FUNCTIONALITY – CREATING AN ASSEMBLY	146
PICTURE 255: CREATING A NEW CATPRODUCT CAD ITEM	147
PICTURE 256: LIST CONTAINING ALL CATPRODUCT TEMPLATE FILES	147
PICTURE 257: CREATING A NEW PART ITEM.....	148
PICTURE 258: LIST CONTAINING TEMPLATE FILES CORRESPONDING TO THE SELECTED PART	148
PICTURE 259: “PDM CREATE IN CONTEXT” CONTEXT MENU ENTRY	148
PICTURE 260: CREATING A NEW PART ITEM IN CONTEXT	149
PICTURE 261: LIST CONTAINING TEMPLATE FILES CORRESPONDING TO THE SELECTED PART IN CONTEXT	149
PICTURE 262: “UPDATE TO PDM” DIALOG AFTER “PDM CREATE IN CONTEXT” ACTION.....	149
PICTURE 263: QUERYING FOR A STANDARD PART	150
PICTURE 264: USING STANDARD PARTS AS A REGULAR USER	151
PICTURE 265: USING STANDARD PARTS IN CATIA STRUCTURES.....	151
PICTURE 266: “UPDATE TO PDM” DIALOG WITH STANDARD PARTS.....	152
PICTURE 267: “UPDATE TO PDM” DIALOG WITH STANDARD PARTS – RESULT	152
PICTURE 268: EXISTING STANDARD PARTS BEING USED IN A NEW STRUCTURE.....	153
PICTURE 269: CATIA CATALOG CONTAINING STANDARD PART CATPARTS	153
PICTURE 270: STANDARD PART CATPARTS CREATED FROM A CATALOG.....	154
PICTURE 271: INSERTED STANDARD PARTS	154
PICTURE 272: “UPDATE TO PDM” DIALOG WITH STANDARD PARTS.....	154
PICTURE 273: UPDATE RESULT	155
PICTURE 274: “SHOW PDM STRUCTURE” ICON	155
PICTURE 275: CAD DOCUMENT STRUCTURE CONTAINING STANDARD PARTS.....	155
PICTURE 276: CATPART WITH DESIGN TABLE.....	156
PICTURE 277: “UPDATE TO PDM” DIALOG CONTAINING A DESIGN TABLE.....	156
PICTURE 278: DESIGN TABLE DOCUMENT RELATED TO CAD DOCUMENT	157
PICTURE 279: EDITING A DESIGN TABLE	157
PICTURE 280: ADDING A LINE TO THE DESIGN TABLE EXCEL SHEET	157
PICTURE 281: THE DESIGN TABLE IS UPDATED IN THE CATIA SESSION.....	158
PICTURE 282: REFRESHED PDM STRUCTURE WINDOW CONTAINING THE DESIGN TABLE.....	158
PICTURE 283: DEFINING A CATPRODUCT STRUCTURE AS AN ARCHIVE	159

PICTURE 284: RESULTING ARCHIVE CAD DOCUMENT IN PDM	159
PICTURE 285: ADD COMPONENT TO CATALOG.....	160
PICTURE 286: SELECT "LOCAL PREVIEW"	160
PICTURE 287: STORE CATALOG DOCUMENT IN ARAS INNOVATOR	161
PICTURE 288: CATALOG EDITOR AFTER UPDATE	161
PICTURE 289: OPEN CATALOG FOR EDIT.....	162
PICTURE 290: OPEN CATALOG BROWSER.....	162
PICTURE 291: CATALOG BROWSER.....	163
PICTURE 292: OPEN AS NEW DOCUMENT	163
PICTURE 293: SELECT LOADED DOCUMENT FOR CATALOG.....	164
PICTURE 294: CONFIGURABLE CATALOG KEYWORDS.....	164
PICTURE 295: CATPROCESS WITH EXTERNAL REFERENCED CATPART IN THE PRODUCTLIST AND INTERNAL COMPONENT IN THE RESOURCESLIST	165
PICTURE 296: ARAS INNOVATOR STRUCTURE OF CATPROCESS WITH EXTERNAL REFERENCED CATPART IN THE PRODUCTLIST AND INTERNAL COMPONENT IN THE RESOURCELIST	165
PICTURE 297: CATPROCESS WITH EXTERNAL REFERENCED STRUCTURES IN THE PRODUCTLIST AND IN THE RESOURCELIST	166
PICTURE 298: ARAS STRUCTURE OF CATPROCESS WITH EXTERNAL REFERENCED STRUCURES IN THE PRODUCTLIST AND IN THE RESOURCELIST.....	167
PICTURE 299: "PDM WORKBENCH OPTIONS" DIALOG – "OPEN LINKED DOCUMENT OF CATPROCESS IN OWN WINDOW"	168
PICTURE 300: EMBEDDED CATIA COMPONENT NODES	168
PICTURE 301: EXAMPLE DOCUMENT CONTAINING ELECTRICAL COMPONENTS	169
PICTURE 302: WARNING ABOUT UNSUPPORTED CATIA COMPONENT NODE	169
PICTURE 303: TWO CATPARTS WITH DIFFERENT REP TYPES RELATED TO THE SAME PART LOADED AT THE SAME TIME	170
PICTURE 304: FILTER REPRESENTATION TYPE COMMAND	170
PICTURE 305: SELECT NON-BOM REPRESENTATION TYPES TO BE LOADED	170
PICTURE 306: MANAGE REPRESENTATIONS	171
PICTURE 307: SAVE MANAGEMENT	171
PICTURE 308: CHECK IF CATIA STRUCTURE IS VALID	172
PICTURE 309: CAD DOCUMENT PROPERTIES IN ARAS INNOVATOR	172
PICTURE 310: EXPAND → ALL POINTED DOCUMENTS	174
PICTURE 311: CREATING A CATDRAWING DOCUMENT WITH A LINK TO 3D GEOMETRY	175
PICTURE 312: PDM MESSAGE ABOUT CREATED DRAWING LINK.....	175
PICTURE 313: EXPANDING NEWLY CREATED DRAWING LINK	175
PICTURE 314: DISPLAYING NEWLY CREATED DRAWING LINK.....	176
PICTURE 315: DISPLAYING ALL CREATED DRAWING LINKS.....	176
PICTURE 316: "AS SAVED" DRAWING LINK	176
PICTURE 317: "CURRENT" DRAWING RELATION	177
PICTURE 318: LOADING "AS SAVED"	177
PICTURE 319: GENERATION 1 OF THE CATPRODUCT STRUCTURE.....	178
PICTURE 320: LOADING "CURRENT"	178
PICTURE 321: GENERATION 2 OF THE CATPRODUCT STRUCTURE.....	179
PICTURE 322: ACTIONS "OPEN WITH RELATED 3D FILES / OPEN WITH CURRENT RELATED 3D FILES" IN "PDM QUERY" DIALOG	179
PICTURE 323: INFORMATION WHEN REFERENCE LINKS ARE CREATED	180
PICTURE 324: INFORMATION WHEN REFERENCE LINKS ARE DELETED	180
PICTURE 325: EXPANDING GEOMETRY LINKS	181
PICTURE 326: GEOMETRY LINK EXPANSION RESULT	181
PICTURE 327: ACTION "RELATE ACTIVE FILE TO PART"	181
PICTURE 328: CONFIRM THE "RELATE ACTIVE FILE TO PART" ACTION – OVERWRITE.....	182
PICTURE 329: INFORMATION PROMPT FOR "RELATE ACTIVE FILE TO PART" ACTION	182
PICTURE 330: ACTION "DELETE RELATION"	183
PICTURE 331: ASSEMBLY IN ARAS INNOVATOR	183
PICTURE 332: STRUCTURE IN PDM WORKBENCH AND CATIA WINDOW	184
PICTURE 333: DELETE BROKEN LINK	184
PICTURE 334: DELETE INSTANCE RELATION.....	184
PICTURE 335: CATPART GEOMETRY IN THE CONTEXT OF A CATPRODUCT STRUCTURE	185
PICTURE 336: CATPART DOCUMENT IN CAD STRUCTURE	186
PICTURE 337: ACTION "SHOW NEIGHBORHOOD".....	186
PICTURE 338: "PDM QUERY" DIALOG FOR CONTEXT ASSEMBLY NODE.....	187

PICTURE 339: REDUCED PDM STRUCTURE CONTAINING ONLY NEIGHBOR MODELS	187
PICTURE 340: REDUCED STRUCTURE LOADED TO CATIA	188
PICTURE 341: THE SELECTED STRUCTURE DOES NOT CONTAIN THE SELECTED CATPART	188
PICTURE 342: "CREATE CORRESPONDING BOM PARTS" CHECK BOX	189
PICTURE 343: CAD STRUCTURE WITH RELATED PART ITEMS	189
PICTURE 344: STRUCTURE WITH FOUR INSTANCES	190
PICTURE 345: ONE CAD STRUCTURE RELATION FOR EACH USED CAD DOCUMENT	190
PICTURE 346: CAD INSTANCE INFORMATION	190
PICTURE 347: ASKING THE USER WHETHER TO CONTINUE THE "UPDATE" PROCESS	191
PICTURE 348: "LOCAL WORKSPACE" ICON	191
PICTURE 349: "LOCAL WORKSPACE" WINDOW	192
PICTURE 350: CREATING CATEGORY "COLOR"	192
PICTURE 351: CREATING OPTIONS "BLUE", "GREEN", AND "YELLOW"	193
PICTURE 352: CREATING BOMCONFIGURATION ITEMS	193
PICTURE 353: CREATING CONFIGURATION EXPRESSION ITEMS	193
PICTURE 354: SAMPLE CATIA STRUCTURE	194
PICTURE 355: RELATING CONFIGURATION EXPRESSIONS TO PLM RELATIONS	194
PICTURE 356: CREATING PRODUCT VARIANT ITEMS	195
PICTURE 357: SETTING A PRODUCT VARIANT FOR THE BOM PART EXPANSION	195
PICTURE 358: EXPANDING AND LOADING THE COMPLETE STRUCTURE	195
PICTURE 359: SETTING DIFFERENT PRODUCT VARIANT EXPAND FILTERS	196
PICTURE 360: LOADED THE "BLUE" VARIANT (ONE BOM INSTANCE)	196
PICTURE 361: LOADED THE "GREEN" VARIANT (ONE PART BOM WITH ALL INSTANCES)	196
PICTURE 362: LOADED THE "YELLOW" VARIANT (ONE BOM INSTANCE)	196
PICTURE 363: "DE-EXPAND" ACTION	196
PICTURE 364: "LOADING PDM STRUCTURES" SETTING	197
PICTURE 365: "CHECK CAD LINKS" ICON	197
PICTURE 366: RESULT OF "CHECK CAD LINKS" ACTION	197
PICTURE 367: PDM STRUCTURE SHOWING EVERY INSTANCE AS A SEPARATE NODE	198
PICTURE 368: EXAMPLE CONTENT OF A PDM STRUCTURE WINDOW	199
PICTURE 369: PWBDOC SAVE DIALOG	199
PICTURE 370: SAVING THE WINDOW CONTENT UNDER A SPECIFIC NAME	200
PICTURE 371: NEWLY CREATED PWBDOC FILE	200
PICTURE 372: OPENING A PWBDOC FILE (1/2)	201
PICTURE 373: OPENING A PWBDOC FILE (2/2)	201
PICTURE 374: OPENING A PWBDOC FILE FROM THE MOST RECENTLY USED FILE LIST	202
PICTURE 375: PDM STRUCTURE WINDOW OPENED FROM PWBDOC FILE	203
PICTURE 376: CATPRODUCT STRUCTURE WITH A DEACTIVATED NODE	204
PICTURE 377: ACTION "UPDATE RELATION CONFIGURATION" SUB-MENU	204
PICTURE 378: CONFIGURATION EXPRESSION ON PART BOM RELATION	205
PICTURE 379: CONFIGURATION EXPRESSION ON BOM INSTANCE RELATION	205
PICTURE 380: "PDM WORKBENCH OPTIONS" DIALOG - SETTING THE RELEASED CACHE OPTIONS	206
PICTURE 381: ACTION "GET ORIGINAL GEOMETRY"	207
PICTURE 382: "OPEN IN CATIA" CONTEXT ACTION	208
PICTURE 383: "OPEN IN CATIA" DIALOG – CAD DOCUMENT STRUCTURE DATA MODEL	209
PICTURE 384: "OPEN IN CATIA" DIALOG – BOM PART STRUCTURE DATA MODEL	209
PICTURE 385: LOADING THE STRUCTURE IN CATIA	210
PICTURE 386: THE LOADED STRUCTURE	210
PICTURE 387: CREATE A "CONSTRUCTION SPACE" ITEM	211
PICTURE 388: "OPEN IN CATIA" OPTION SELECTION	212
PICTURE 389: "OPEN IN CATIA" WITH PREDEFINED CONSTRUCTION SPACE	212
PICTURE 390: "OPEN IN CATIA" WITHOUT PREDEFINED CONSTRUCTION SPACE	212
PICTURE 391: "OPEN IN ARAS" CONTEXT ACTION	213
PICTURE 392: "OPEN IN ARAS" TOOLBAR ACTION	213
PICTURE 393: SINGLE DRAWING LINK TO A CATPART	214
PICTURE 394: CATPART'S PDM ITEMS PRE-SELECTED IN "PDM CREATE" DIALOG FOR CATDRAWING	214
PICTURE 395: SELECT CONTEXT PRODUCT	215
PICTURE 396: CURRENTLY USED CONTEXT PRODUCT	215
PICTURE 397: PDM WORKBENCH OPTIONS	216
PICTURE 398: "CUSTOMIZE LIST VIEW" DIALOG	216

PICTURE 399: "CUSTOMIZE LIST VIEW" DIALOG FOR "ASSEMBLY"	217
PICTURE 400: PREVIEW OF THE "LIST VIEW" DIALOG.....	217
PICTURE 401: PDM WORKBENCH TOOLBAR AFTER LOGIN.....	218
PICTURE 402: ACTION "COPY ELEMENT ATTRIBUTES".....	221
PICTURE 403: "PDM CREATE" DIALOG FOR ASSEMBLY	222
PICTURE 404: "PDM CREATE" DIALOG FOR ASSEMBLY – INSERTED ATTRIBUTE VALUES.....	222
PICTURE 405: CATIA STRUCTURE BEFORE AND AFTER IMPORT TO PDM	223
PICTURE 406: "LOGIN" DIALOG WITH AUTONAME RULE.....	223
PICTURE 407: "SET PDM CONFIGURATION" DIALOG.....	223
PICTURE 408: AUTONAME RULE COMBO BOX IN "SET PDM CONFIGURATION" DIALOG.....	224
PICTURE 409: SELECTED AUTONAME RULE DISPLAYED IN "UPDATE TO PDM" DIALOG	224
PICTURE 410: PDM STRUCTURE NAMED BY SEQUENCE ITEM.....	224
PICTURE 411: SELECTING A CUSTOM METHOD ON A PART ITEM	225
PICTURE 412: DIALOG WITH PRE-FILLED ATTRIBUTES	225

CHAPTER 1

Overview

This chapter provides basic information about the *PDM Workbench* and lists some features of this application.

Introducing PDM Workbench

The *PDM Workbench* is developed by T-Systems as a high-end integration between the CAD system *CATIA V5* and several PDM systems. Those PDM systems might be customized or virtual (a combination of several PDM systems). No matter which type they are the PDM Workbench will integrate them into *CATIA V5*. How those PDM object types are to present their dialogs and functionalities within the PDM Workbench is defined in a configuration file (called *PDM Workbench Schema File*).

The PDM Workbench workshop works with two different windows. The first window type presents the results of your queries. There you also might expand your PDM structure. Or you can create new objects in this window.

You can load this PDM structure into a *CATIA V5* native window, and you can modify the content of this *CATIA V5* native window (see *Picture 1: PDM Workbench workshop in CATIA V5*).

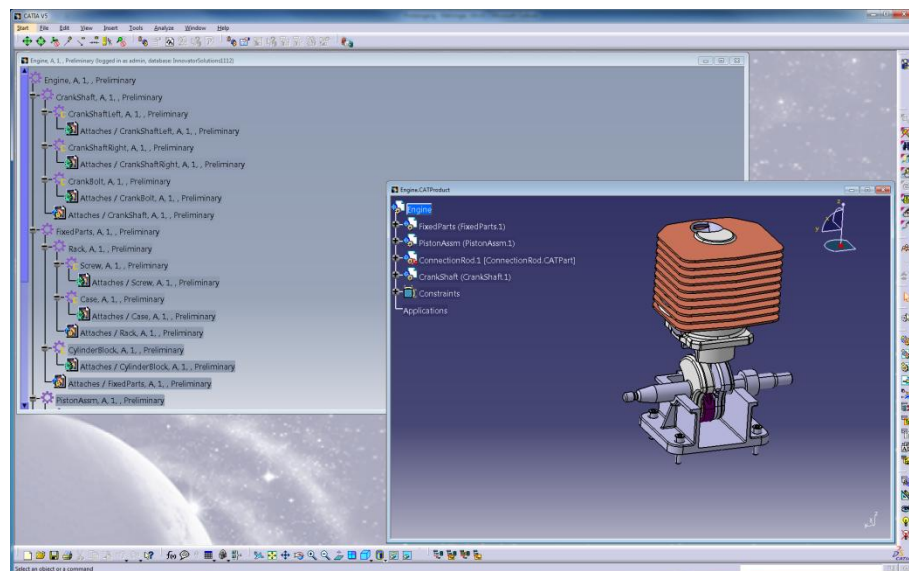

Picture 1: PDM Workbench workshop in CATIA V5

The PDM Workbench maps the structure in the PDM system and the structure of the *CATIA* files. The *CATProducts* and *CATParts* are identified by their Part Number and file types like *.CATDrawing or *.cgr are identified by their File Name. The modified structure can be updated in the PDM system. The Part Numbers and File Names are controlled by the PDM system.

For new CATParts and CATProducts new Parts will be created in the PDM system. Also if a Part Number is changed in CATIA the CATProduct/CATPart will become a new object in the PDM system.

CHAPTER 2

Supported Data Models

The PDM Workbench supports two different data models:

- BOM Part Structure Data Model
- CAD Document Structure Data Model

BOM Part Structure Data Model

In the *BOM Part Structure Data Model* the PDM structure is represented by Parts (Assembly or Component). The relation "Part BOM" is used.

Each Part is described by a CAD Document which includes the CATIA file for a CATProduct, CATPart, or CATDrawing (see *Picture 2: PDM structure in the BOM Part Structure Data Model*).

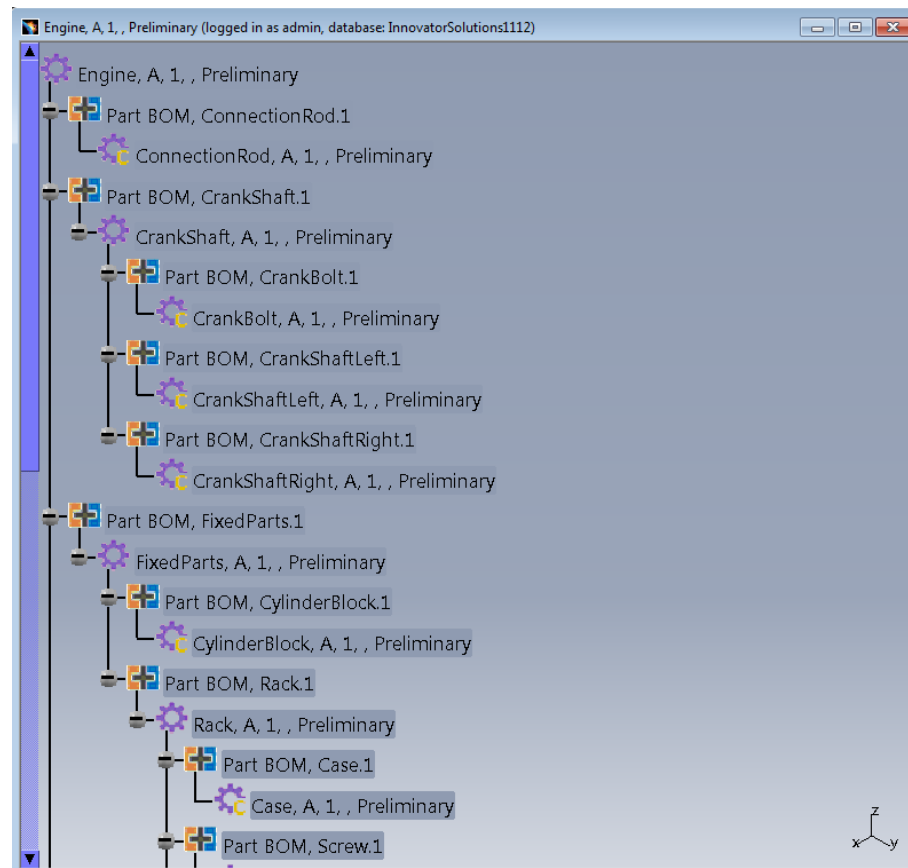

Picture 2: PDM structure in the BOM Part Structure Data Model

CAD Document Structure Data Model

In the *CAD Document Structure Data Model* the PDM structure is represented by CAD Documents. The relation "CAD Structure" is used.

Each CAD Document includes the CATIA file for a CATProduct, CATPart, or CATDrawing (see *Picture 3: PDM structure in the CAD Document Structure Data Model*).

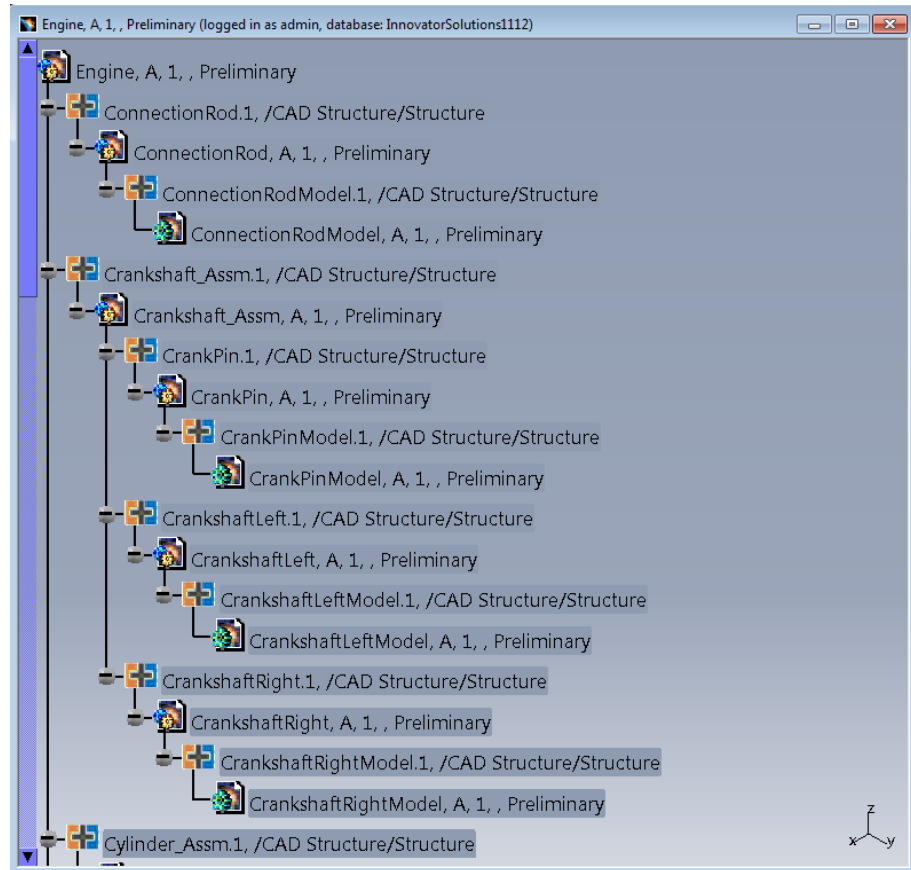

Picture 3: PDM structure in the CAD Document Structure Data Model

CHAPTER 3

Getting Started

This chapter describes the functionality of the PDM Workbench which is implemented in the CATIA V5 workshop.

We suppose that you have installed CATIA V5 with the PDM Workbench workshop on your computer. All configurations for the PDM Workbench (including the configurations for the PDM system) are done properly.

Note: All user actions described below are based on the corresponding configuration of the data model and the actions to be provided by the PDM system.

Login

In order to access the PDM Workbench functionality you must log in into the PDM system.

You select the “Login” icon  within the PDM Workbench toolbar (see *Picture 4: The PDM Workbench toolbar before the login*) in CATIA V5. The other PDM Workbench icons remain deactivated.



Picture 4: The PDM Workbench toolbar before the login

The following dialog (see *Picture 5: “Login” dialog*) prompts you for all information necessary to identify yourself in the PDM system. In our example you are asked to enter your “User”, “Password”, and “Database”. The identification items marked with an asterisk are defined as necessary for Login in the PDM Workbench configuration file.

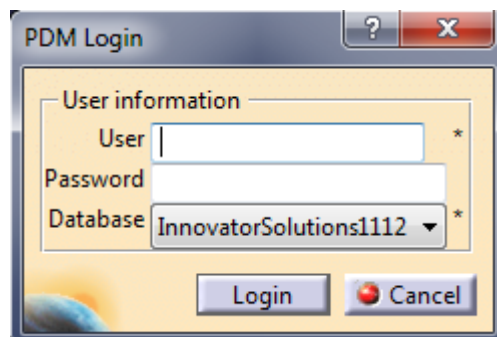

Picture 5: “Login” dialog

Click the “Login” button.

Once the login action was successful most of the icons in the PDM Workbench toolbar will turn active while some will remain inactive as they depend on further user actions to be done to get them available (see *Picture 6: The PDM Workbench toolbar after the login*).

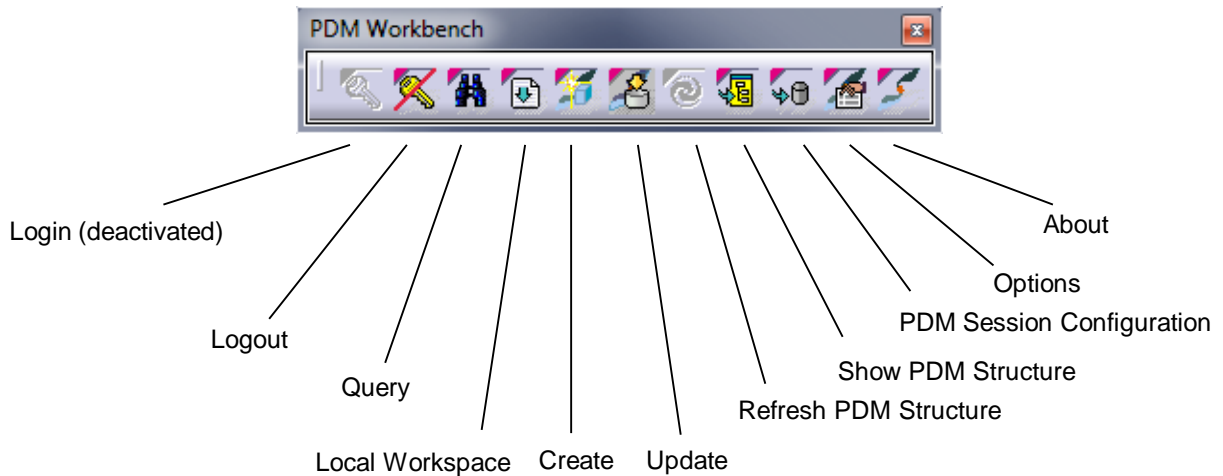

Picture 6: The PDM Workbench toolbar after the login

For CATPart and CATDrawing as top-level object of the CATIA V5 window you have to use the actions "PDM Properties", "Unclaim", "Claim", and "Duplicate" of the "PDM Workbench context commands" toolbar (see *Picture 7: The PDM Workbench context commands toolbar*). The icons in this toolbar are only repainted (e.g. switch from "Claim" to "Unclaim") when you newly activate the CATIA V5 window.

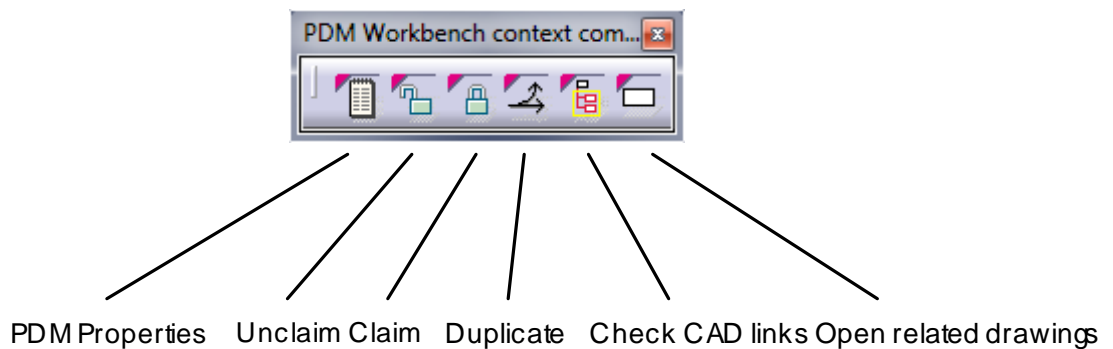

Picture 7: The PDM Workbench context commands toolbar

Query

You can query for any object stored in the PDM system.

Once you click the "Query" icon  within the PDM Workbench toolbar the "PDM Query" dialog opens. On the left side of the dialog you can define the query criteria. On the right side you will see the query results (see *Picture 8: "PDM Query" dialog*).

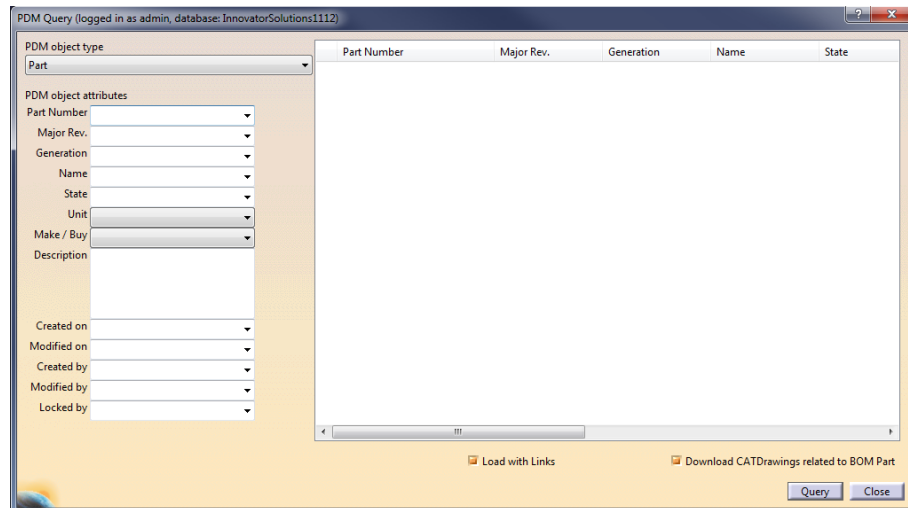

Picture 8: “PDM Query” dialog

The query criteria are defined by the type and the attributes for this type. A default type is selected and its attributes are shown.

You can select a type in the single selector list in the first line. The attributes will be shown automatically.

Specify your selection criteria in the lines below (see *Picture 9: “PDM Query” dialog – enter query criteria*).

You can use the wildcard “*” in this dialog. All attributes visible in this dialog are attributes of the PDM system for the selected object type. (These attributes as well as their adherence to the “PDM Query” dialog of this type are defined in the PDM Workbench configuration file).

Some attribute values can be keyed in as free text while for others a value might be selected from a list.

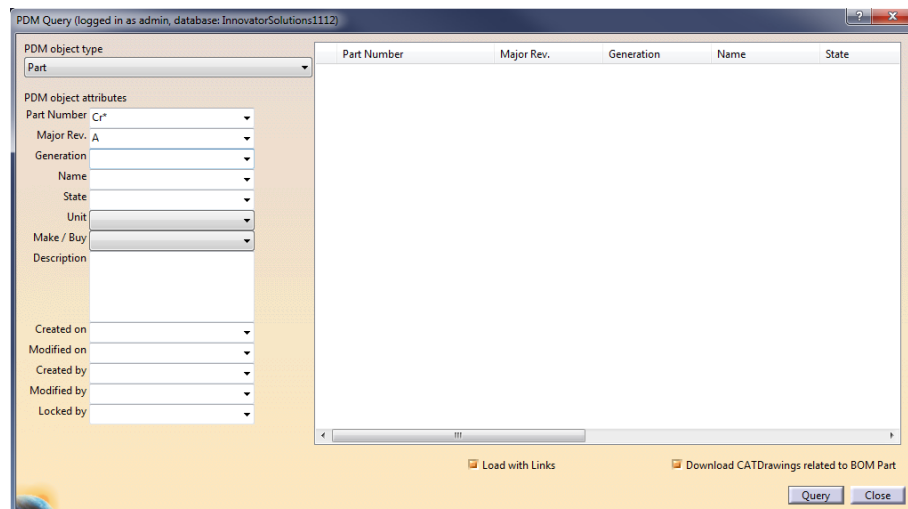

Picture 9: “PDM Query” dialog – enter query criteria

When you have specified the selection criteria you can start the query for PDM objects with a click on the “Query” button.

In the settings of the PDM Workbench you can define the columns for the query result on the right side of the dialog (see chapter *Options - Query Dialog*).

The found objects will be presented on the right side of the dialog. By clicking on the column name, you can sort the query result (see *Picture 10: “PDM Query” dialog – found objects*).

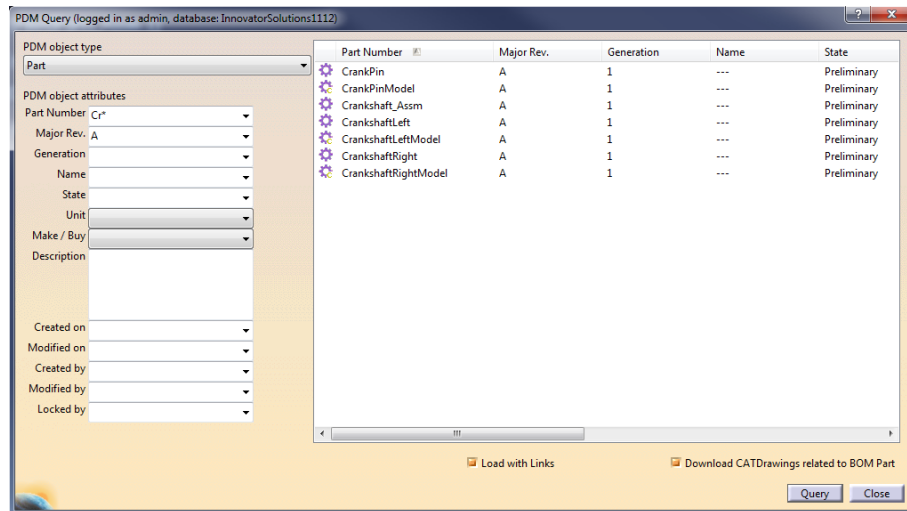

Picture 10: “PDM Query” dialog – found objects

There you can select the object or the objects to be opened in a new PDM Workbench window. Click on the right mouse button and select “Open in new PDM Window” (see *Picture 11: “PDM Query” dialog – Action “Open in new PDM Window”*).

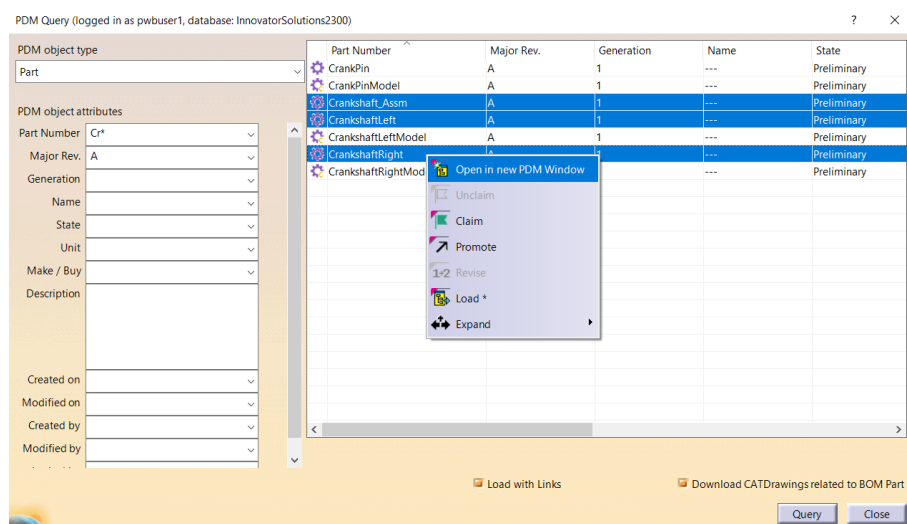

Picture 11: “PDM Query” dialog – Action “Open in new PDM Window”

A double click on a single object opens it in a new PDM Workbench window.

Now you can close the “PDM Query” dialog by clicking on the “Close” button.

The found objects are opened in the PDM Workbench window now (see *Picture 12: Query result in PDM Structure window*).

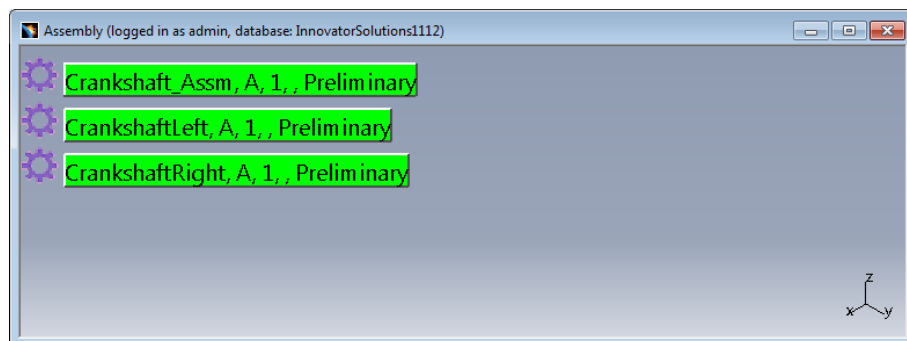

Picture 12: Query result in PDM Structure window

“Select Date” Widget

It can be complicated to write a date in the correct format into the date fields of the query dialog. With this functionality you can select the dates from a calendar widget.

The date fields have a button on the right of the attribute value. Clicking on that button opens the “Date Selection” dialog:

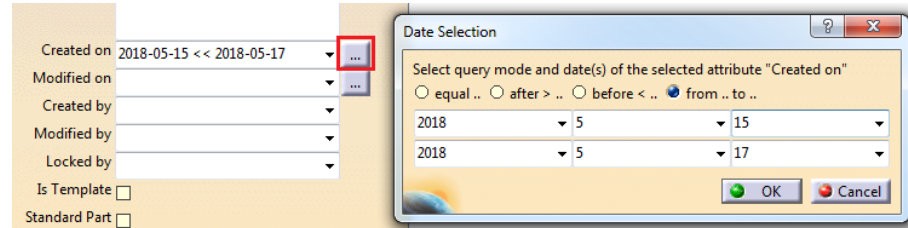

Picture 13: Date Field and Date Selection Dialog

In this dialog you can choose the options

- equal ..
Query for objects with a specific date. Only the values of the first date have to be selected.
- after > ..
Query for objects newer than the selected date. Only the values of the first date have to be selected.
- before < ..
Query for objects older than the selected date. Only the values of the first date have to be selected.
- from .. to ..
Query for objects between two dates. The values of both dates have to be selected.

The values of the dates can be selected from the drop down lists. The user can also type in the values manually.

After OK is pressed the date is filled into the query dialog:

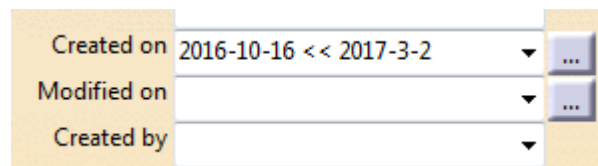

Picture 14: Date field filled after the “Date Selection Dialog”

Download Drawing Option

In the BOM Part Structure Data Model the “Query” result dialog contains a check box with which you can define whether CATDrawings related to the part being loaded should also be downloaded.

In this example two CATDrawing documents are related to the part item, in addition to the CATPart document (see *Picture 15: CATDrawing documents related to part item*):

Document Number	Revision	Name	Type	State	Native File [...]	Viewable File [...]	Authoring Tool
NewPart1	A		Mechanical/Part	Preliminary	NewPart1.CATPart	Select file...	CATIA
NewPart1-Drw1	A		Mechanical/Drawing	Preliminary	NewPart1-Drw1.C...	Select file...	CATIA
NewPart1-Drw2	A		Mechanical/Drawing	Preliminary	NewPart1-Drw2.C...	Select file...	CATIA

Picture 15: CATDrawing documents related to part item

When the check box is checked (see *Picture 16: “Query” result dialog with “Download CATDrawing related to BOM Part” check box*) then the related CATDrawings are downloaded and opened in the CATIA session when the part is loaded (see *Picture 17: CATDrawings opened in CATIA session*).

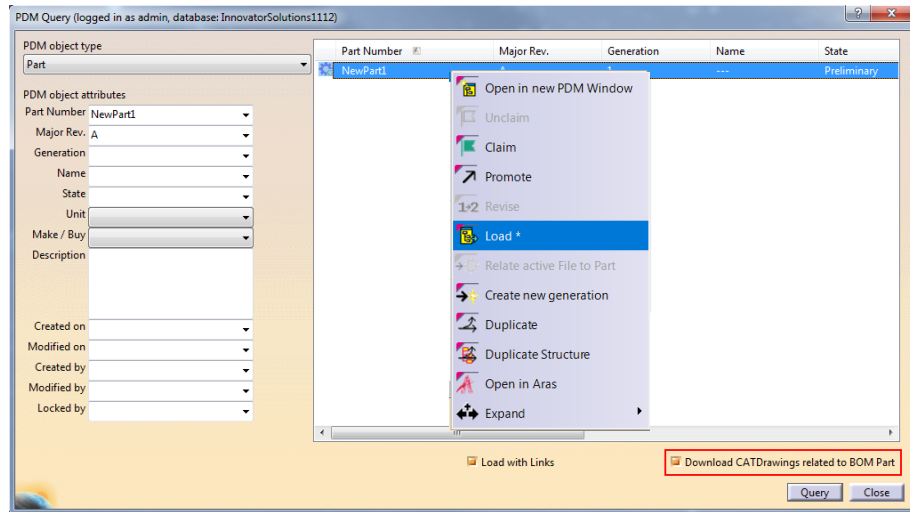

Picture 16: “Query” result dialog with “Download CATDrawing related to BOM Part” check box

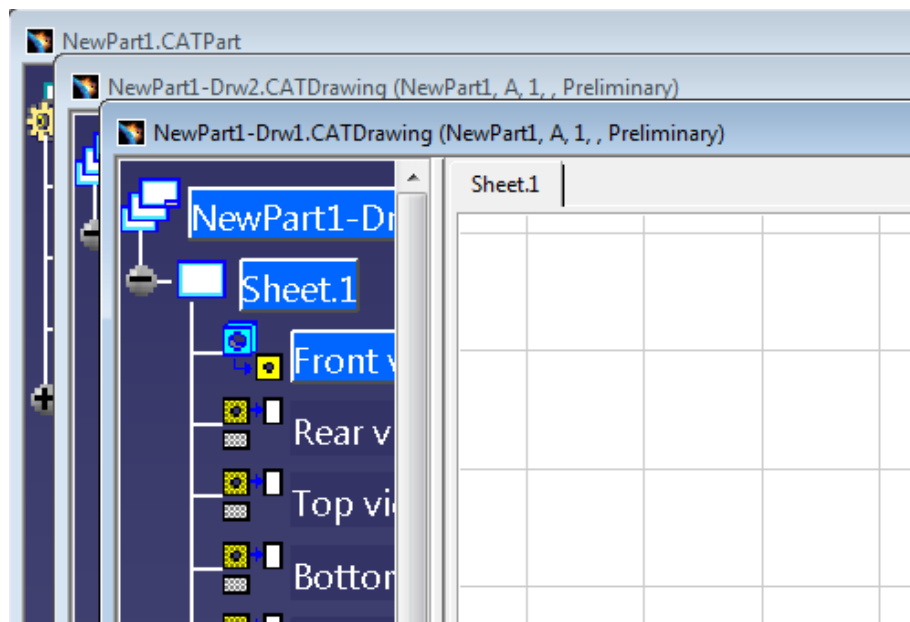

Picture 17: CATDrawings opened in CATIA session

Automatically loading CATDrawings or linked CATParts

It is possible to automatically load linked CATDrawings or CATParts when a CATPart or a CATProduct structure is loaded. There are two check boxes in the “PDM Query” dialog where this behavior can be set (see *Picture 18: “Load with Links” and “Load with Drawings” check boxes*).

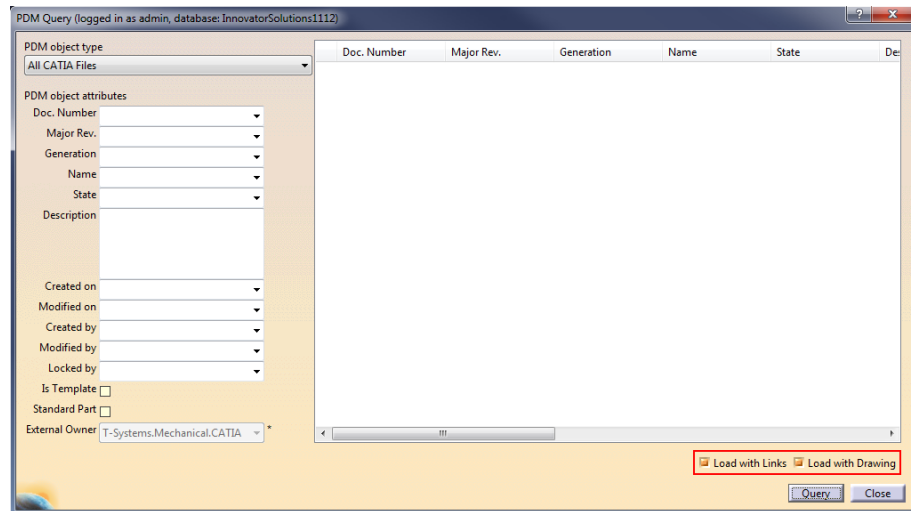

Picture 18: “Load with Links” and “Load with Drawings” check boxes

If the corresponding checkboxes are checked simply opening the CATPart document or loading the CATProduct will also load the related CATDrawing or the linked CATPart documents.

Additional Options for “Load with Links”

The “Load with Links” functionality is used to download documents referenced by CATParts (Aras Innovator relation (default): “/CAD Structure/Reference”) (see *Picture 19: Activate “Load with Links”*).

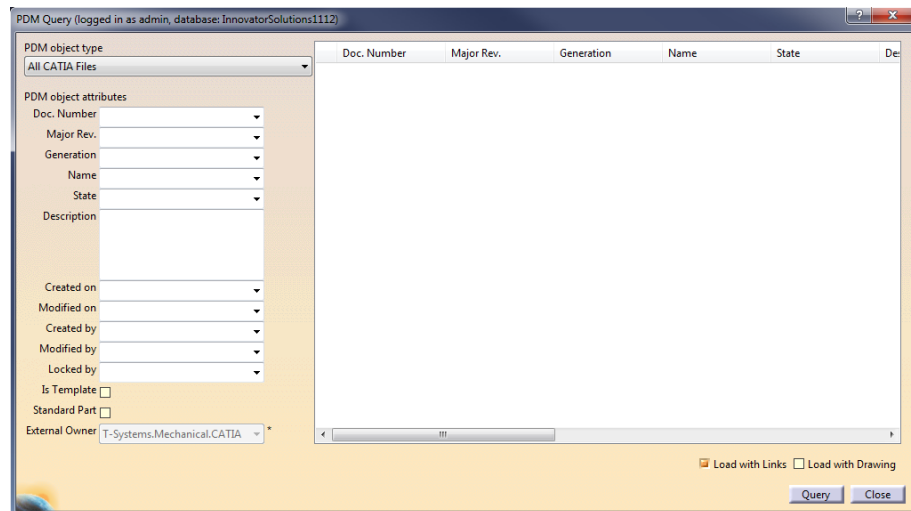

Picture 19: Activate “Load with Links”

By default, the functionality only downloads the linked files into the PDM Workbench exchange directory to make sure that there is no broken link in the referencing CATPart.

In addition to the standard behaviour you can choose three options in the PDM Workbench options panel (see *Picture 20: Additional options for “Load with Links”*).

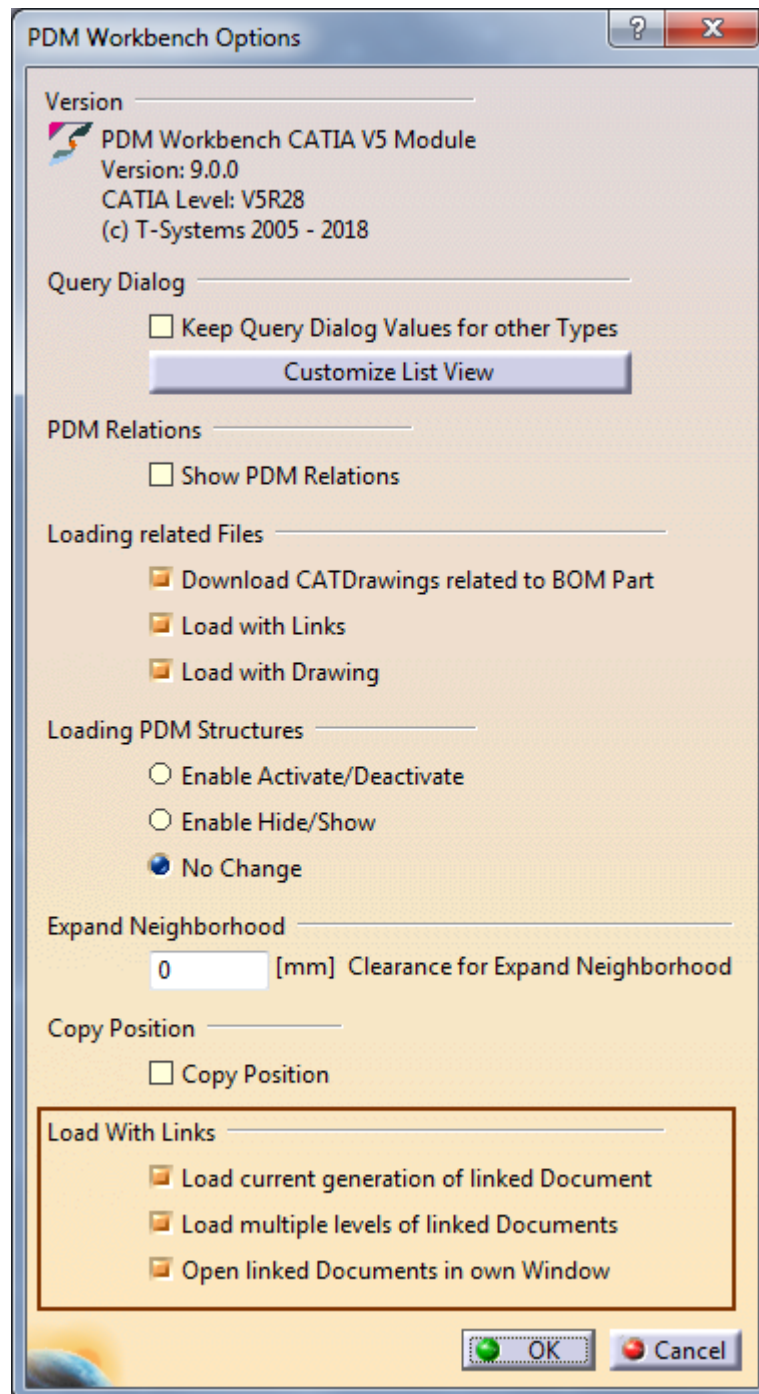

Picture 20: Additional options for “Load with Links”

- Load current generation of linked Document:
Get the “Current” generation instead of “AsSaved”
(this option cannot be used if UseCadStructureVariantExpand=true)
- Load multiple levels of linked Documents:
Also load the documents referenced by a referenced document.
- Open linked Documents in own Window:
This option is only available in CAD Document Structure Data Model.
The linked documents are opened in their own CATIA window and can be used in the same way as if they were opened normally (Update, Claim, Unclaim, ...)

Filter Attribute Values are kept when changing the Type

If the value of an attribute is set, and if the new type has an attribute with the same name, then the value is kept for the new type.

This example shows how the document number attribute value for querying CAD Documents is kept when you switch to querying Part items.

The first query is for All CATIA Files with the criteria Document Number “Engine*” (see *Picture 21: Document number query value for CAD Documents*).

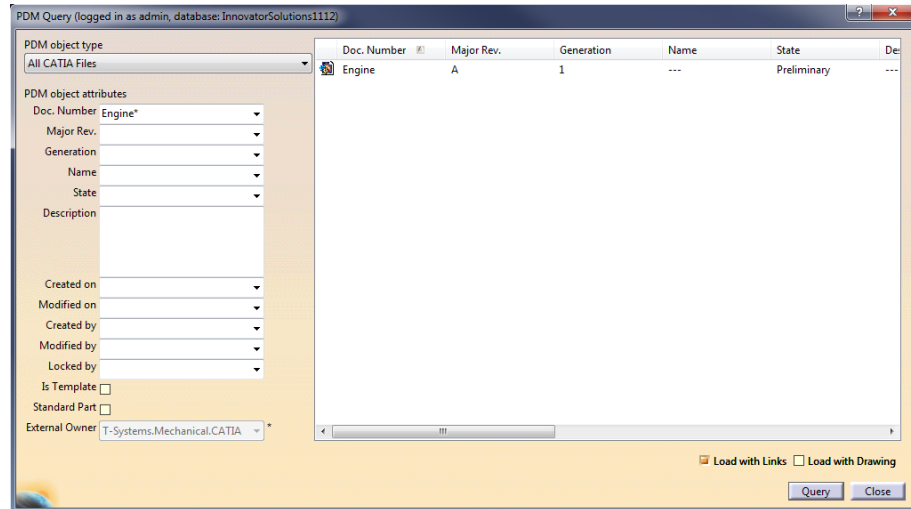

Picture 21: Document number query value for CAD Documents

Then the type will be changed to “Part” (see *Picture 22: Switching to Part items*).

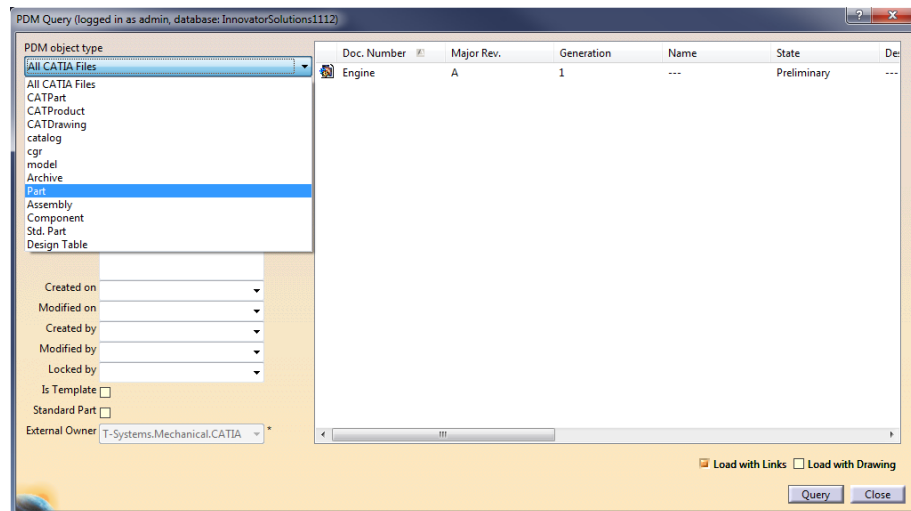

Picture 22: Switching to Part items

The query criteria remains “Engine*” for the Part Number attribute (see *Picture 23: Part number value is taken from CAD Document number value*).

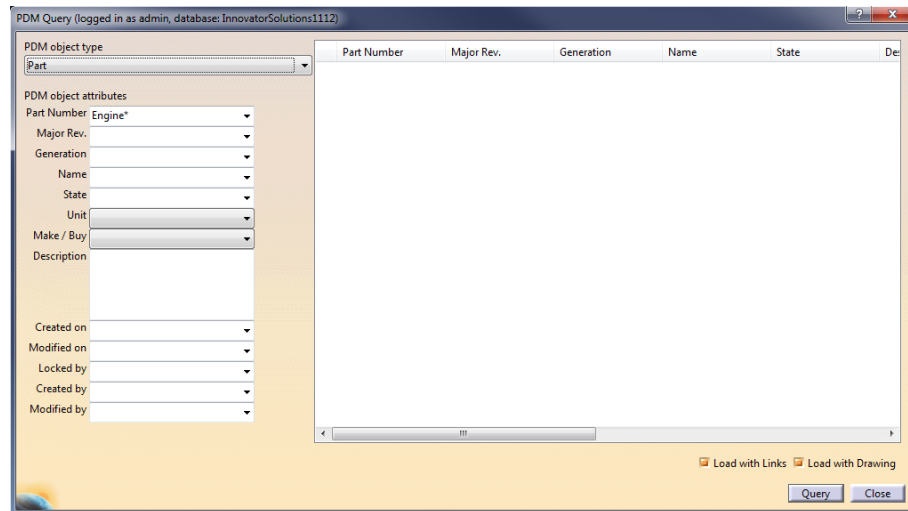

Picture 23: Part number value is taken from CAD Document number value

Load of multiple Assemblies in the Query Dialog

It is possible to select multiple CATProduct CAD Documents in the query dialog for loading. The functionality makes sure that the generations included in the selected structures are unique, that is, that only one generation of each CAD Document is loaded.

Expand Single Level

You can expand from the selected object to other related objects via several relations in two directions.

Select the object from which you want to expand and open the context menu by clicking on the right mouse button. Select the context action “Expand”. The “Expand” sub menu offers the possible relation directions for expansion from the selected object.

In the example you select the direction “Uses Part BOM” for the selected “Assembly” object “Engine” (see *Picture 24: Action “Expand Single Level”*).

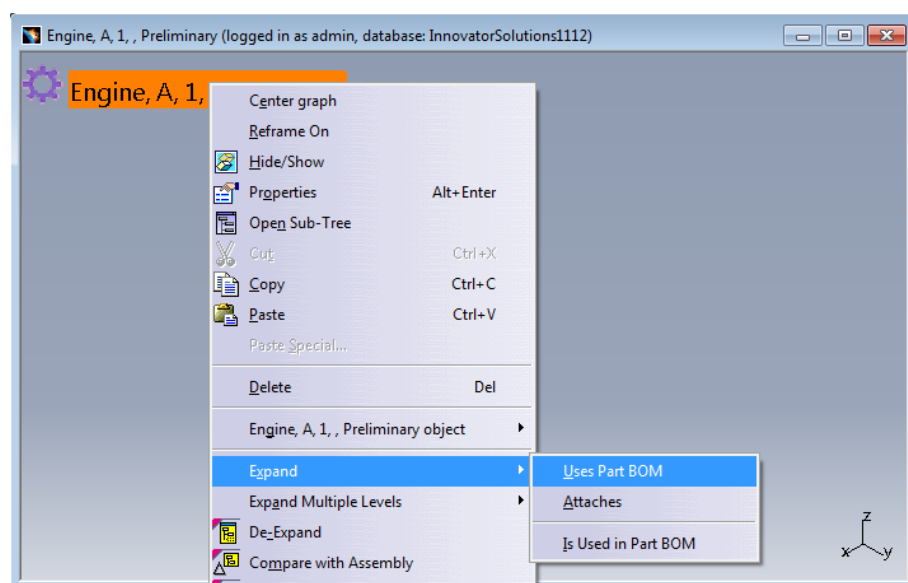

Picture 24: Action “Expand Single Level”

The related objects for the selected “Assembly” object “Engine” are shown (see *Picture 25: Result of expand single level*).

In the PDM structure tree you can see the objects and relations. The type of the relation is displayed in braces in the line of the relation.

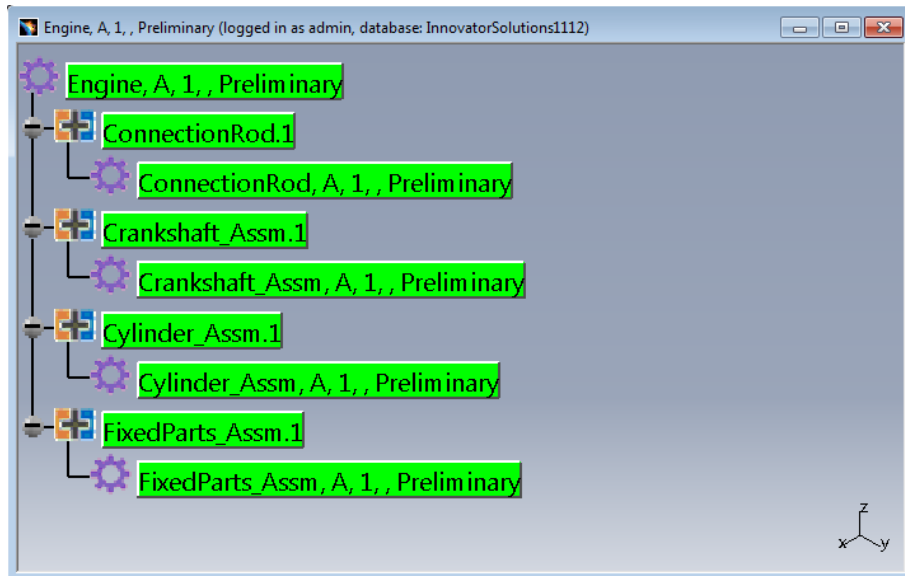

Picture 25: Result of expand single level

When you have switched off the display of the relations in the options (see *Options - PDM Relations*) then the expand tree looks like displayed (see *Picture 26: Result of expand single level without relations*).

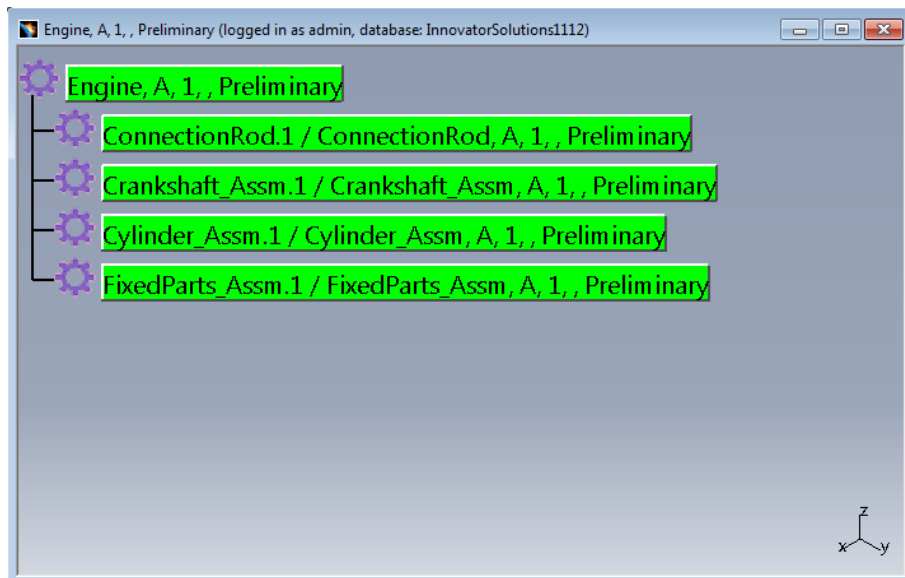

Picture 26: Result of expand single level without relations

The type of the relation, the revision, and the generation of the relation are displayed in the braces in the line of the relation. The attributes can be configured in the PDM Workbench configuration file.

“Current” and “Released” Expand Modes for “CAD Structure”

In addition to the default expand mode for the CAD structure (“As Saved”) the modes “Current” and “Released” are supported.

Two new CAD structure expand modes are available, “Current” and “Released” (see *Picture 27: Three CAD structure expand modes*).

The existing default mode is the “AsSaved” mode.

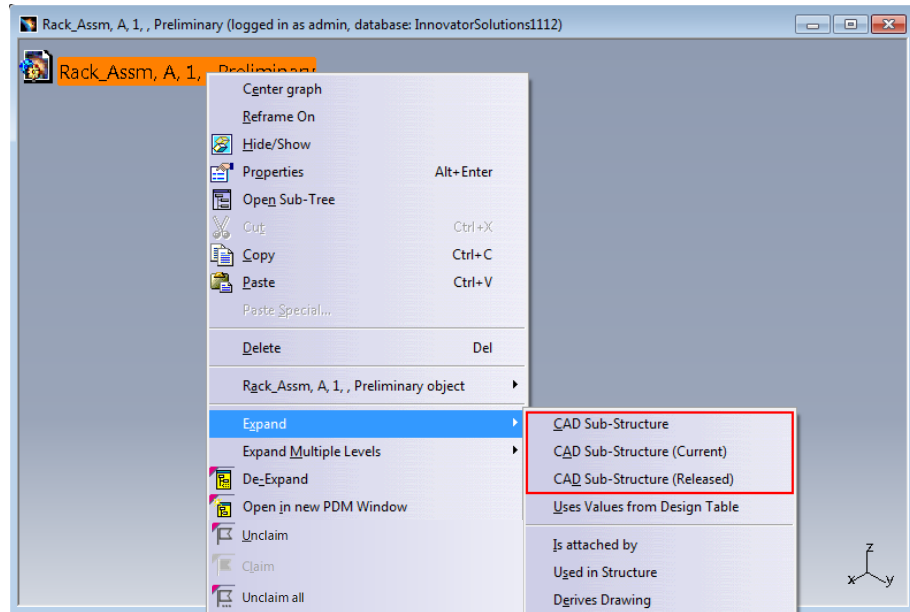

Picture 27: Three CAD structure expand modes

In an example, a CATPart in a structure exists in two generations, generation 1 and generation 2. Generation 1 of the model has no whole (see *Picture 28: Generation 1 of CATPart*).

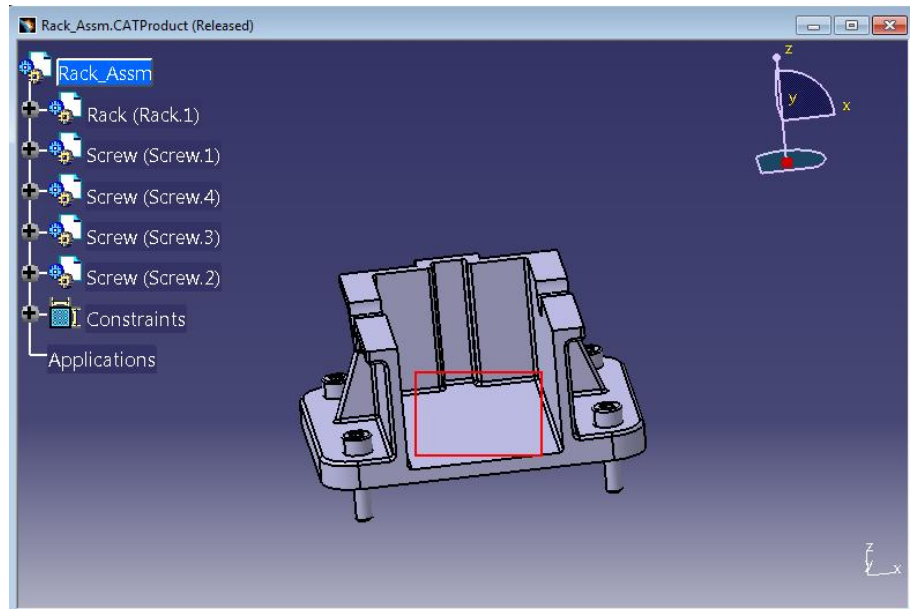

Picture 28: Generation 1 of CATPart

The structure in PDM uses the generation 1 of the CAD Document (see *Picture 29: CAD structure containing generation 1 of CATPart*).

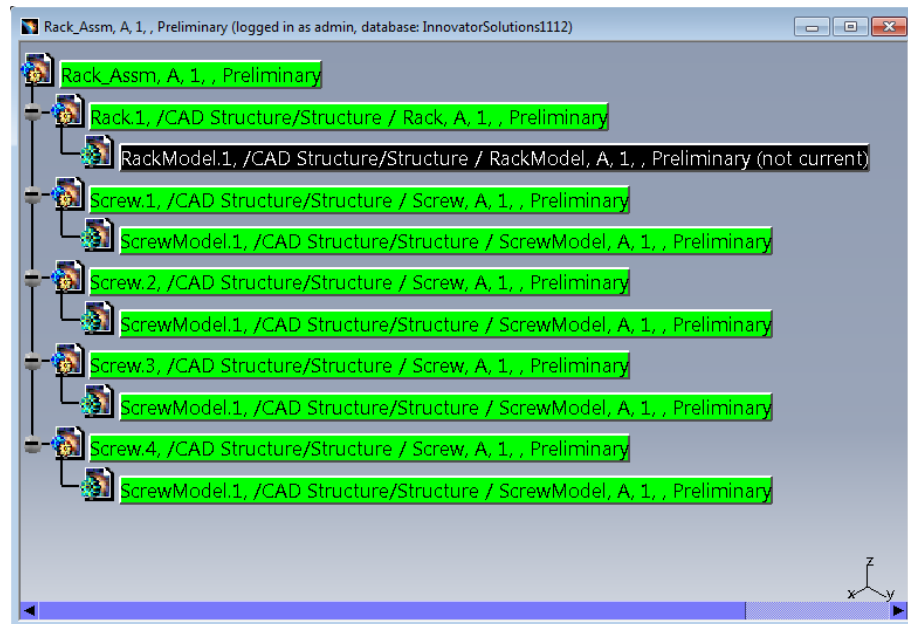

Picture 29: CAD structure containing generation 1 of CATPart

When a CATIA structure is loaded in one expand resolution it is not possible to expand the structure using a different expand mode. If you attempt that, you get a warning (see *Picture 30: Warning about different expand resolution*).

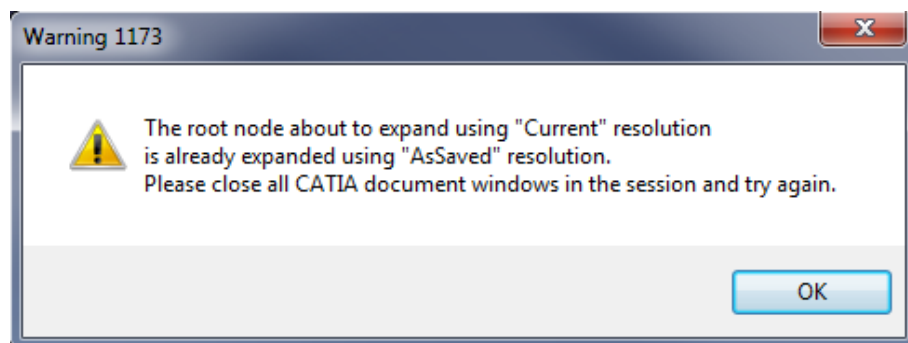

Picture 30: Warning about different expand resolution

When all CATPart and CATProduct windows are closed, it is possible to expand the structure using a different expand resolution, for instance “Current” (see *Picture 31: CAD structure expanded as “Current”*).



Picture 31: CAD structure expanded as “Current”

The “Current” structure, which contains the latest generations of all CAD Documents, can be loaded into the CATIA session (see *Picture 32: CATIA structure containing the latest generations of the CATIA documents*).

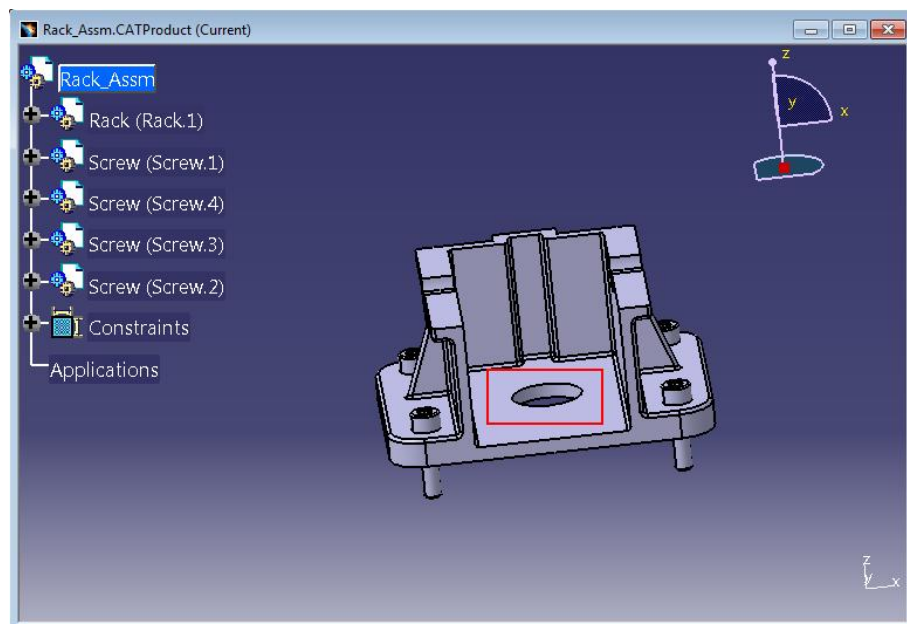

Picture 32: CATIA structure containing the latest generations of the CATIA documents

When you update a CATIA structure that was not expanded as saved a confirmation dialog appears (see *Picture 33: Confirm “Update” action*). If you continue the update, all the CAD structure relations in the loaded structure will be updated to the current generations of the documents.

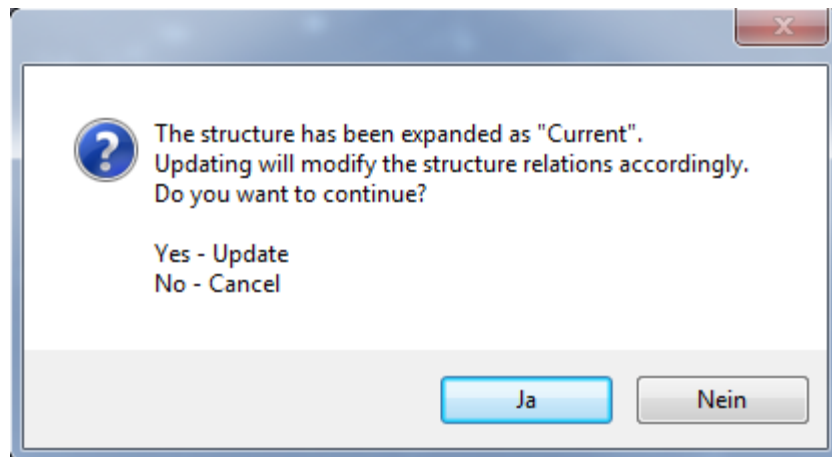

Picture 33: Confirm “Update” action

Expand Multiple Levels

It is also possible to expand a relation direction in multiple levels from the selected object.

Select the object from which to be expanded and open the context menu by clicking on the right mouse button. Select the context action “Expand Multiple Levels”. The “Expand Multiple Levels” sub menu offers the possible relation directions for expansion from the selected object.

In the example the direction “Uses Part BOM” for the selected “Assembly” object “Engine” is selected (see *Picture 34: Action “Expand Multiple Levels”*).

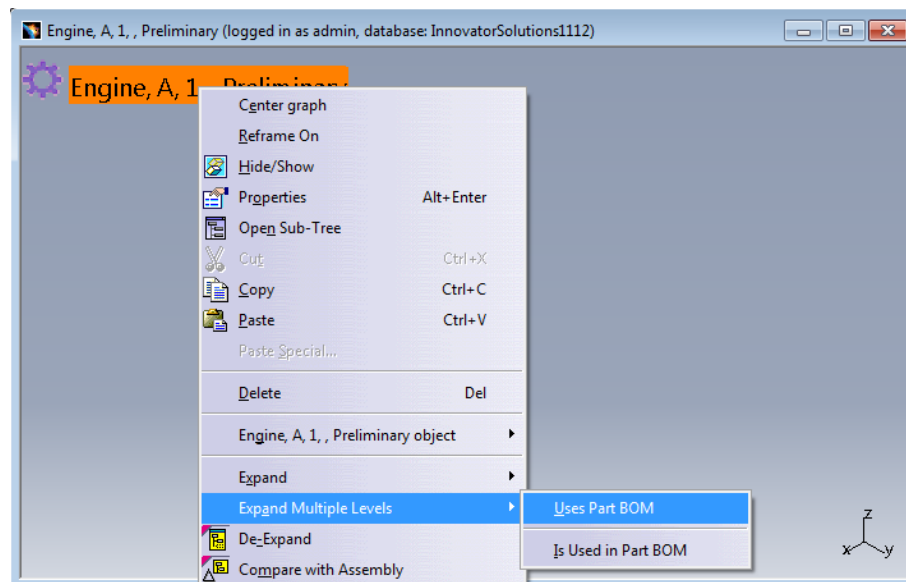

Picture 34: Action “Expand Multiple Levels”

The related objects in multiple levels are shown for the selected “Assembly” object “Engine” (see *Picture 35: Result of expand multiple levels*).

In the PDM structure tree you can see the objects and relations. The type of the relation, the revision, and the generation are displayed in braces in the line of the relation.

When you have switched off the display of the relations in the options (see *Options - PDM Relations*) then the relation objects will not be displayed in the expanded PDM structure tree.

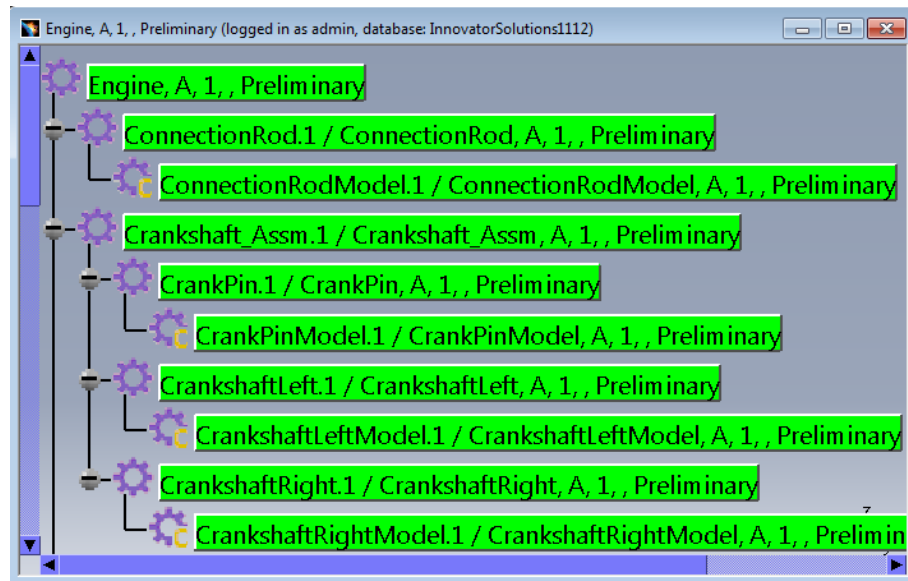

Picture 35: Result of expand multiple levels

Explicit Display and Control of “AsSaved” and “Current” Expand Resolutions

If a CAD structure is expanded with the “Current” expand resolution the PDM structure window contains information about which generations of the CAD Documents are saved (which generation would be retrieved with the “AsSaved” expand resolution).

Also, in the “Update” process the user can define whether the CAD Structure relations should be moved to the current generation of the child CAD Document or not.

Expanding a CAD structure as “Current” where some of the nodes are saved in an older generation shows which generation of the CAD Document is saved:

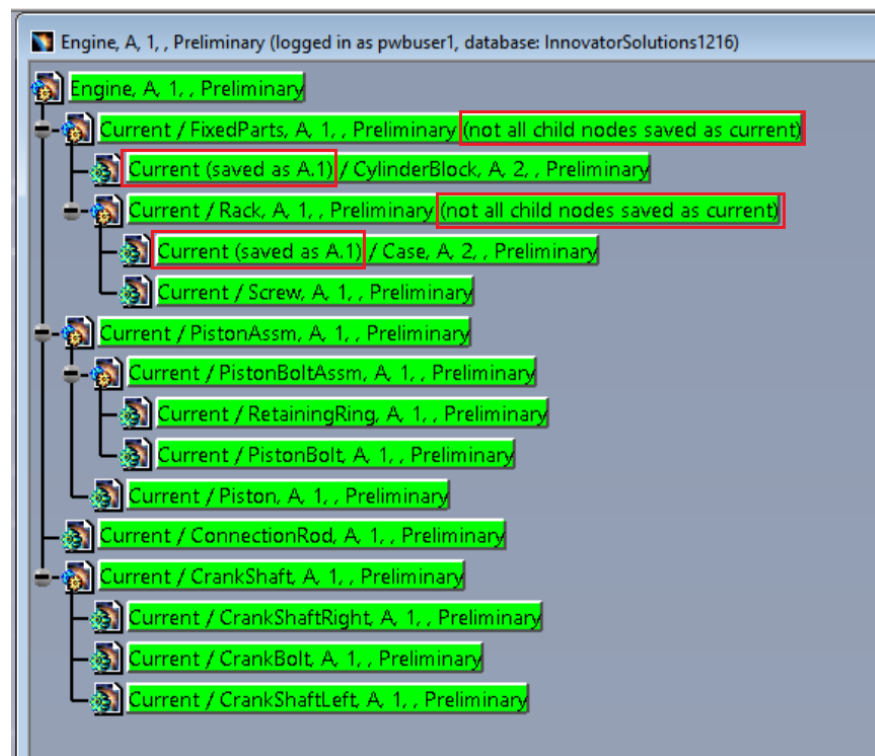

Picture 36: CAD Structure expanded as “Current”

As a comparison, this is the same structure expanded “AsSaved”:

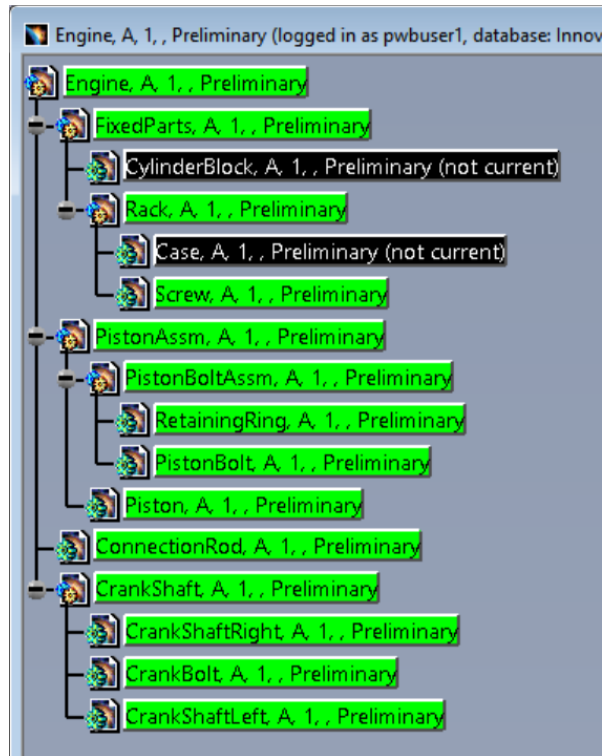

Picture 37: CAD Structure expanded “AsSaved”

If a CAD structure has been expanded as “Current” then in the “Update to PDM” dialog the user has the choice whether to update the CAD Structure relations to the current CAD Document generation. The default is “Yes”. If the structure is not changed then the user can change this to “No”, thereby keeping the CAD Structure relations pointing to the old CAD Document generations:

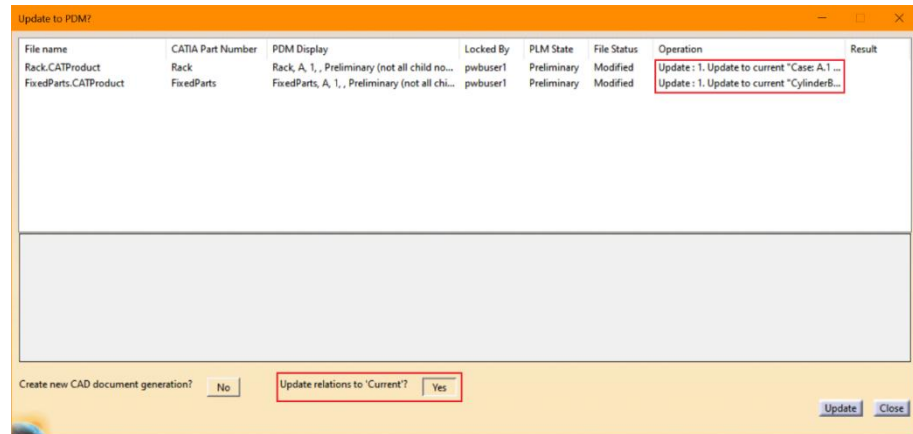

Picture 38: “Update to PDM” dialog with “Update to Current” information

De-Expand

When you want to reduce the displayed PDM structure then you can de-expand parts of the structure.

In *Picture 39: PDM structure before the De-Expand* you can see the PDM structure before the de-expand.

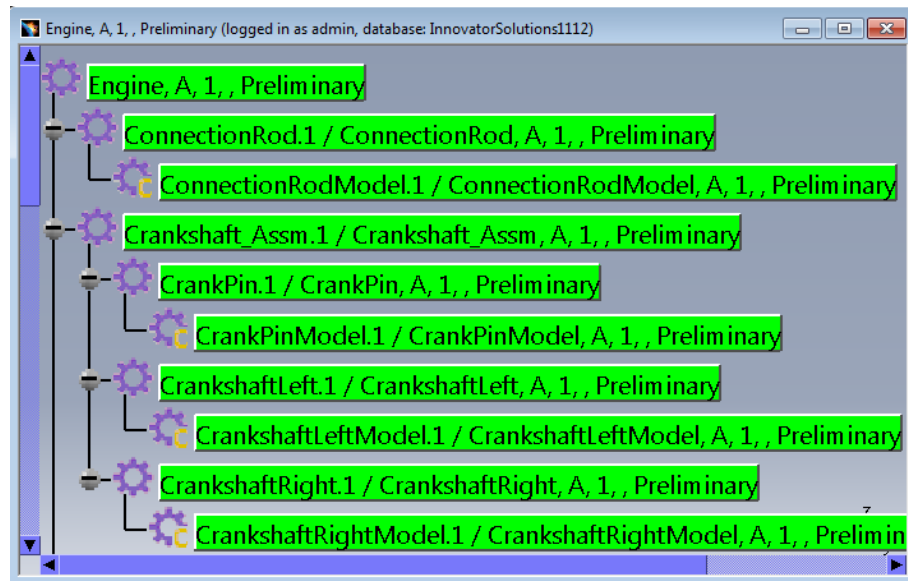

Picture 39: PDM structure before the De-Expand

First you select the root element of the substructure which you want to de-expand. You also might de-expand a single object. Then you open the context menu by clicking the right mouse button and you select the action “De-Expand”.

In the example you select the object “FixedParts_Aasm” as root of the substructure to be de-expanded (see *Picture 40: Action “De-Expand”*).

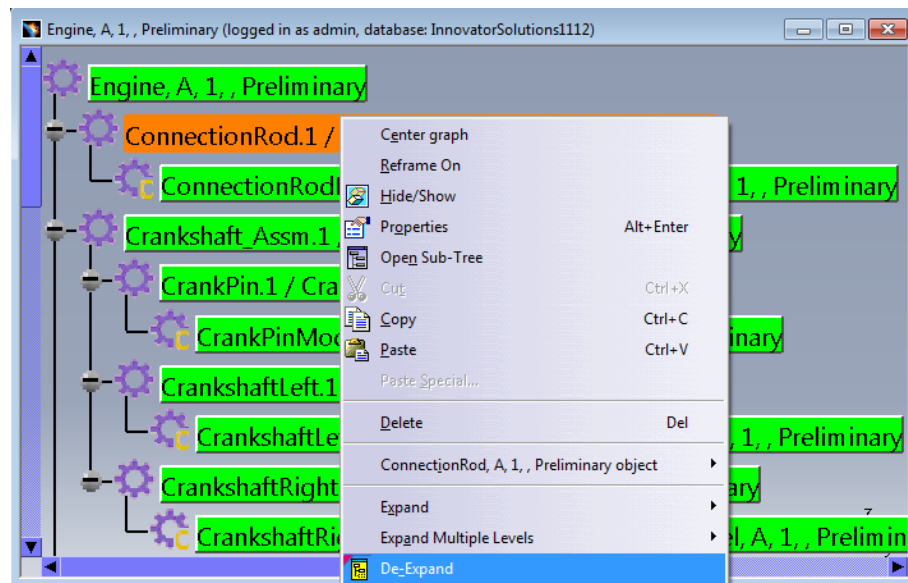

Picture 40: Action “De-Expand”

In *Picture 41: PDM structure after the De-Expand* you see that the selected substructure with the root element “FixedParts_Aasm” is de-expanded as it is no longer displayed in the PDM structure.

But remember that the PDM structure will not be modified by this de-expand. The substructure will not be deleted from the PDM structure.

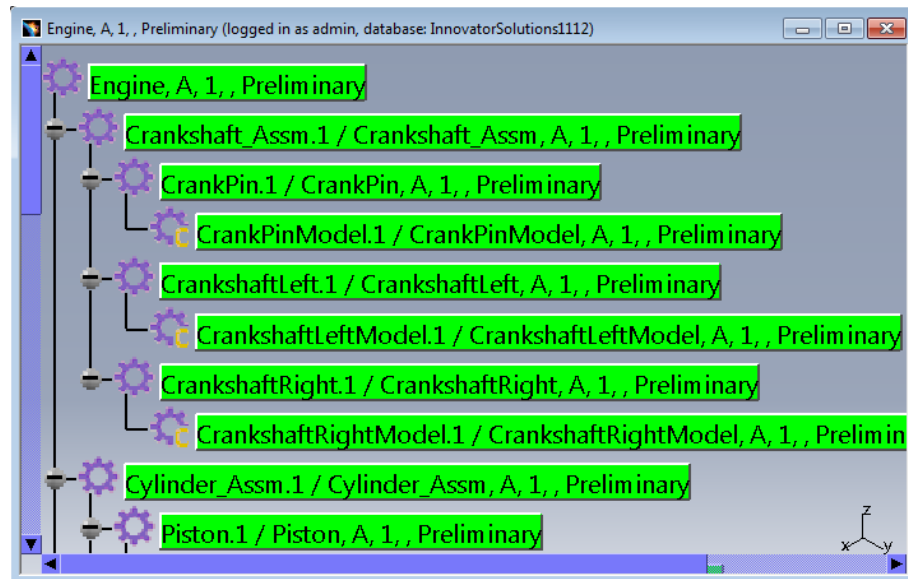

Picture 41: PDM structure after the De-Expand

Properties

The PDM properties of the objects in the PDM Workbench window are transferred from the PDM system when the objects are displayed in the PDM Workbench window for the first time, e.g. when they are shown as a result of a query or an expand action.

You take a look at those properties and/or change these properties when opening the “Properties” dialog. Therefore, click on the right mouse button. Now the context menu opens and you select the action “Properties” (see *Picture 42: Action “Properties”*).

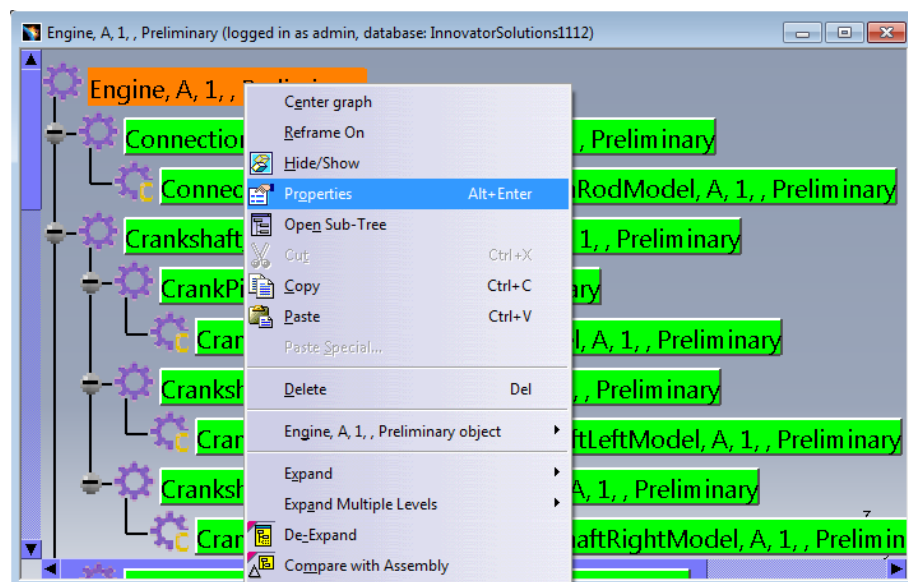

Picture 42: Action “Properties”

The “Properties” dialog will be opened (see *Picture 43: “Properties” dialog – tab “Properties”*). It consists of two tabs.

In the tab “Properties” the values of the attributes are shown on a grey background. This indicates that the values cannot be changed. All properties that are shown within this dialog can be specified within the PDM Workbench configuration file.

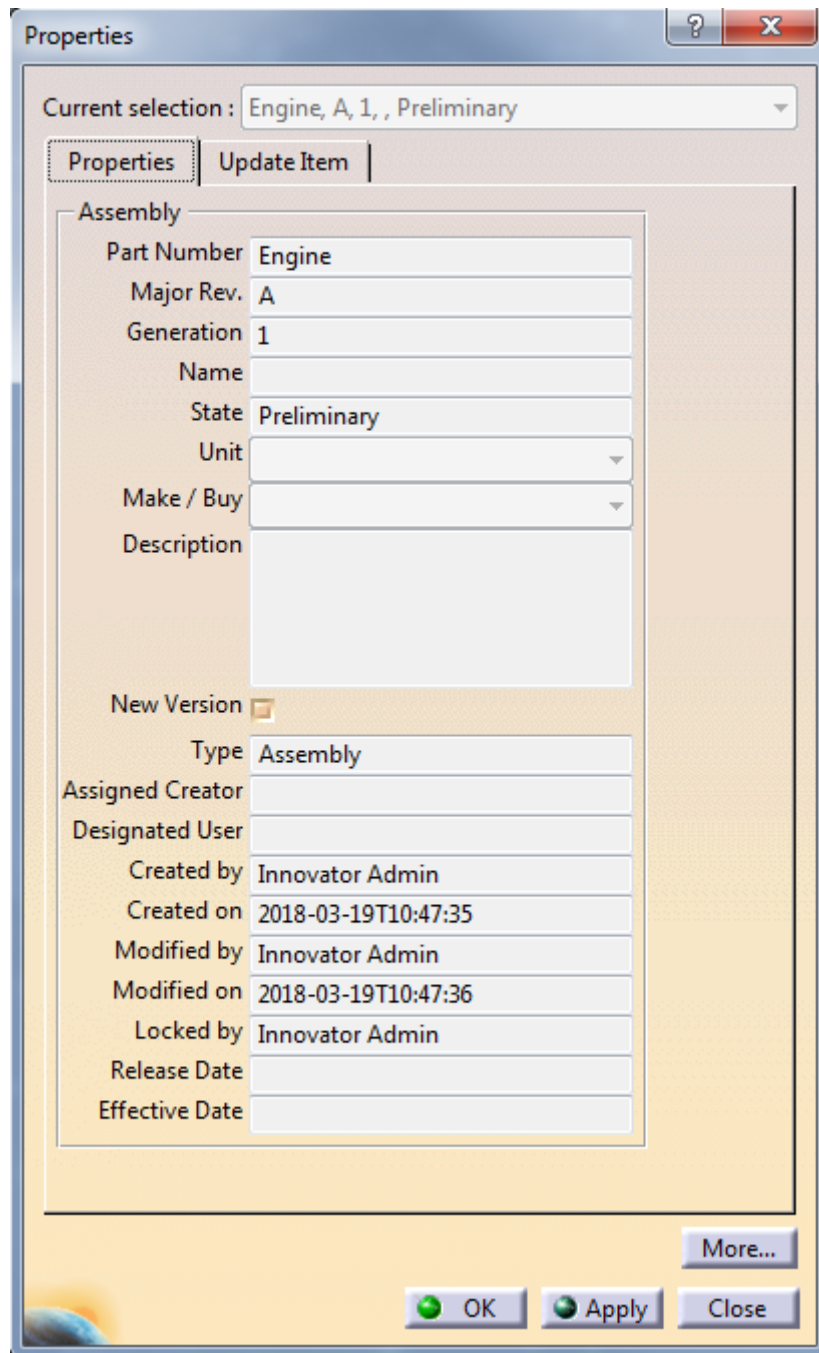

Picture 43: “Properties” dialog – tab “Properties”

In the tab “Update Item” those attribute values shown on a grey background cannot be changed. Those presented with the white background can be changed (see *Picture 44: “Properties” dialog – tab “Update Item”*).

Required attributes are marked with an asterisk (*) on the right side of the input field.

There are several types of attributes presented on corresponding widgets:

- Free text can be inserted.
- One value can be selected in a single selector list or combo box for instance or any other widget.
- Multiple values can be selected in a multi selector list or other widget types supporting this feature.
- The value can be marked or unmarked in a check box for instance.

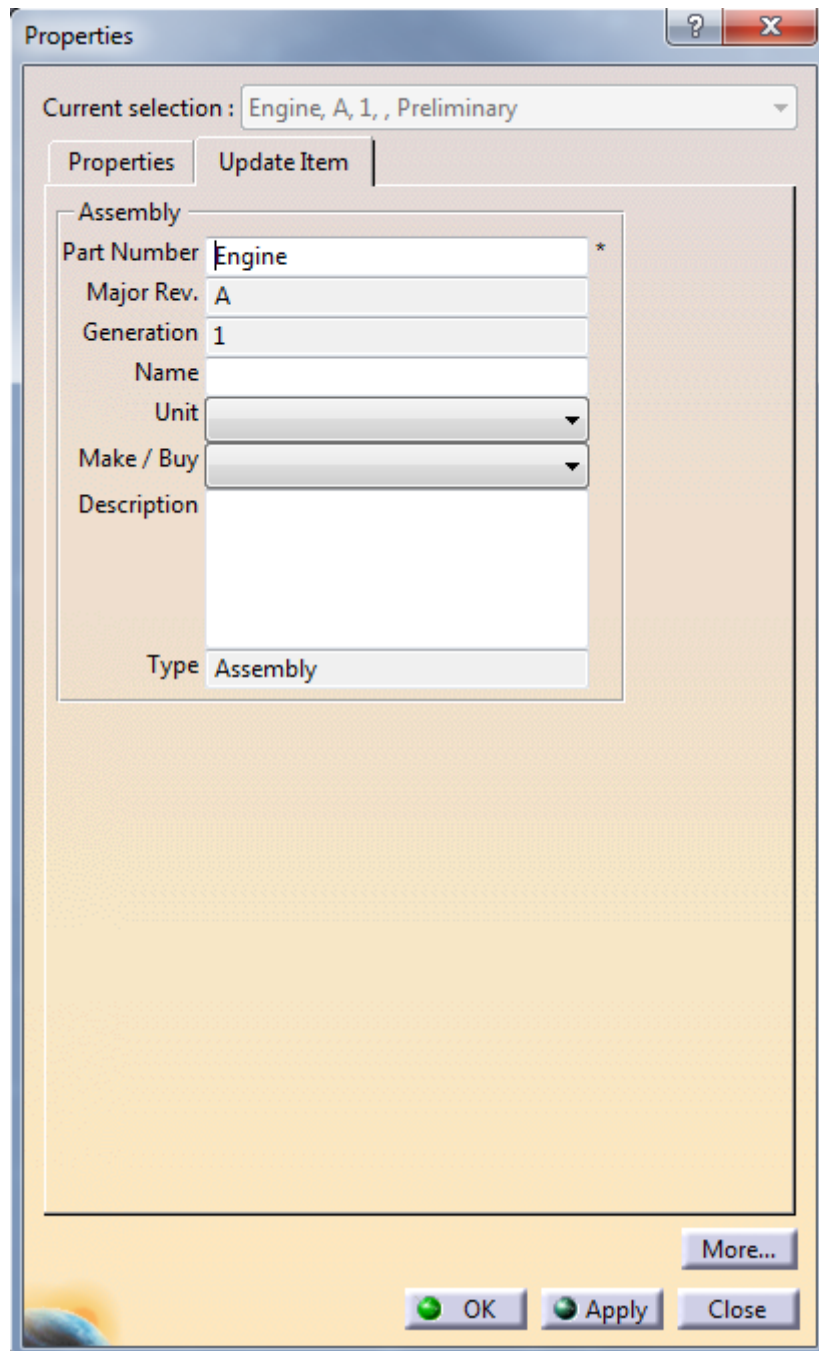

Picture 44: “Properties” dialog – tab “Update Item”

Please use the “OK” button to close the “Properties” dialog.

In the tab “Update Item” the required attributes get checked for being satisfied. If not, you will get an error window that describes your fault.

The object gets updated in the PDM system database according to the “Update to PDM” dialog values. When the update is not possible in the PDM system (because of a wrong value of an attribute or different reasons) then you will get an error window.

The PDM system properties of a CATPart and CATDrawing as top-level object of the CATIA V5 window cannot be inspected with the context menu. You have to use the “PDM

Properties” button  within the “PDM Workbench context commands” toolbar. The values of the attributes are in read-only mode. You are not able to make changes on the PDM system attributes in this dialog.

Claim

Claim Part in PDM Workbench Window

You have to claim the PDM objects prior to changing and updating them.

So you select the object in the PDM Workbench window and click the right mouse button. In the context menu you select the context action “Claim” (see *Picture 45: Action “Claim”*). This action is only active in the context menu when it is possible for the selected object. Otherwise, it will be deactivated in the context menu.

A multi-select of objects is also supported.

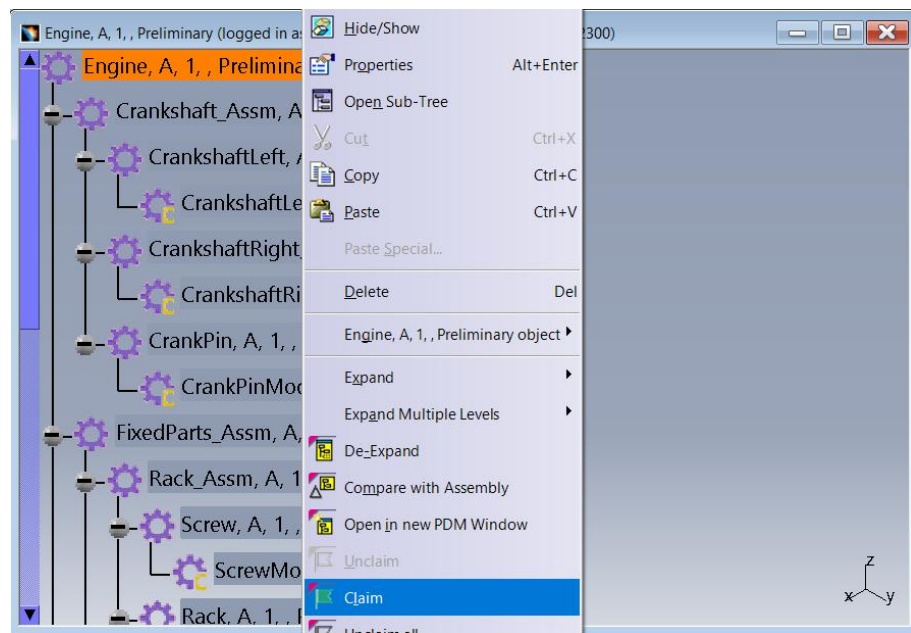

Picture 45: Action “Claim”

The selected object and the attached documents will be claimed by you (see *Picture 46: Object is claimed*).

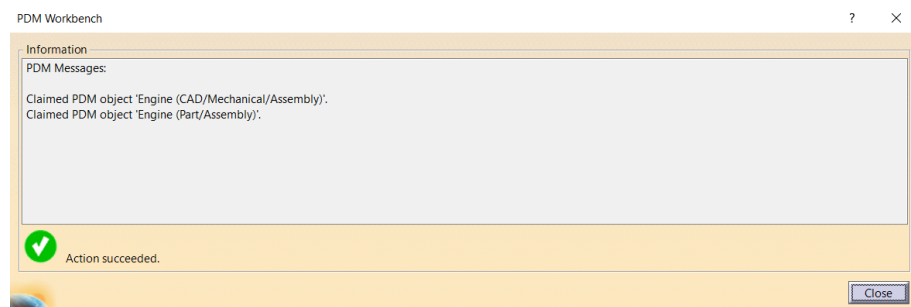

Picture 46: Object is claimed

The background color of the claimed object changed to green in the PDM Workbench window (see *Picture 47: Claimed object*).

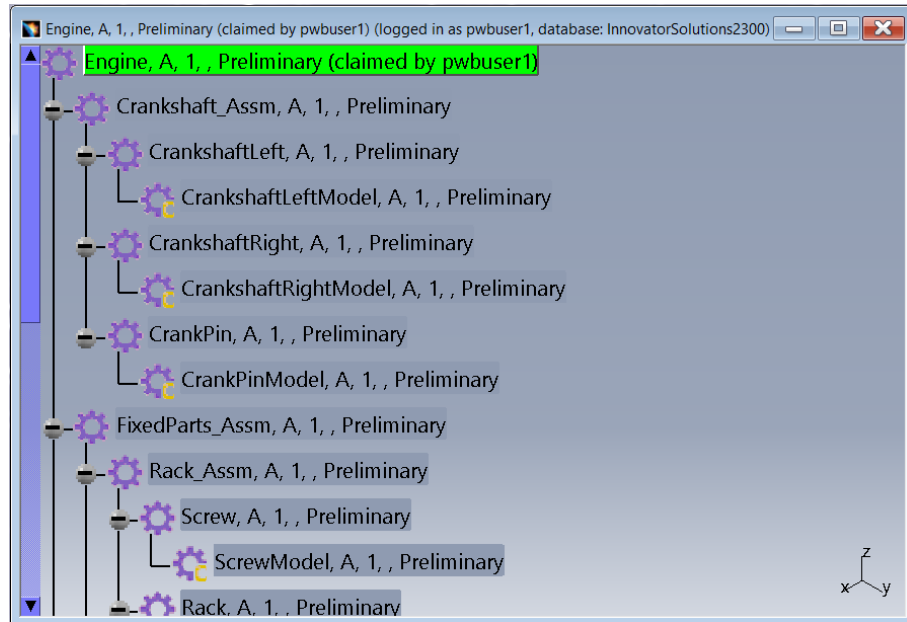

Picture 47: Claimed object

The green background color of the claimed object indicates that the object in the PDM system can be changed by you.

Claim Object in Query Dialog

It is also possible to claim the object from the query result list of the "PDM Query" dialog. In the example you select the object and click on "Claim" in the context menu (see *Picture 48: Action "Claim" in the query result list*). This action is only active in the context menu when it is possible for the selected object. Otherwise, it will be deactivated in the context menu.

A multi-select of objects is also supported.

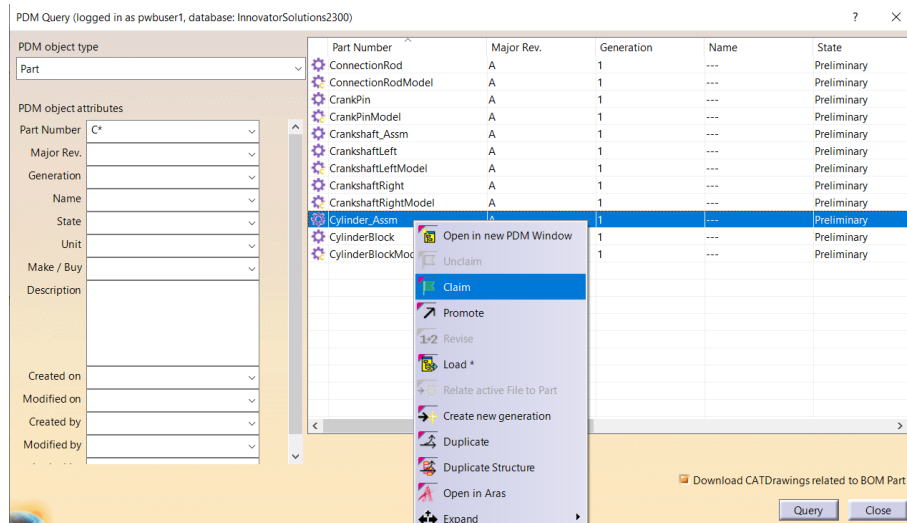

Picture 48: Action "Claim" in the query result list

Claim Document in CATIA V5 Window

You have to claim the PDM objects prior to changing and updating them.

You select the object in the CATIA V5 window and click the right mouse button. In the context menu you select the context action *PDM Workbench* → *Claim* (see *Picture 49: Action “Claim” in the CATIA V5 window*).

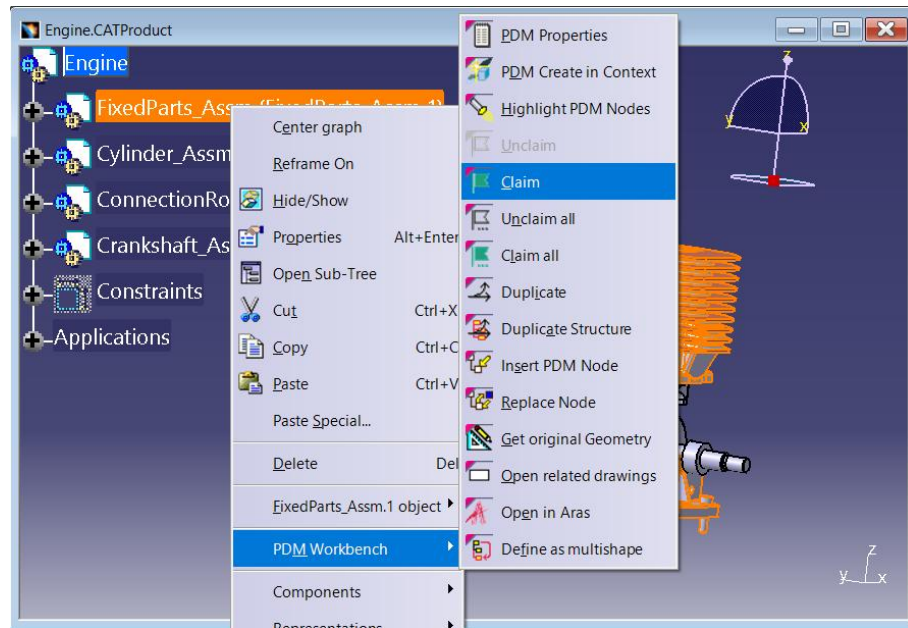

Picture 49: Action “Claim” in the CATIA V5 window

For further details of the “Claim” dialogs please refer to the chapter *Claim Part in PDM Workbench Window*.

The claim of a CATPart and CATDrawing as top-level object of the CATIA V5 window cannot be done with the context menu. You have to use the “Claim” button of the “PDM Workbench context commands” toolbar. The icons in this toolbar are only repainted (e.g. switch from “Claim” to “Unclaim”) when you newly activate the CATIA V5 window.

A multi-select of objects is also supported.

Unclaim

Unclaim Part in PDM Workbench Window

When an object is claimed by you then you have to unclaim it in the PDM system to make it available for all other users.

You select the object in the PDM Workbench window and click the right mouse button. In the context menu you select the “Unclaim” context action (see *Picture 50: Action “Unclaim”*). This action is only active in the context menu when it is possible for the selected object. Otherwise, it will be deactivated in the context menu.

A multi-select of objects is also supported.

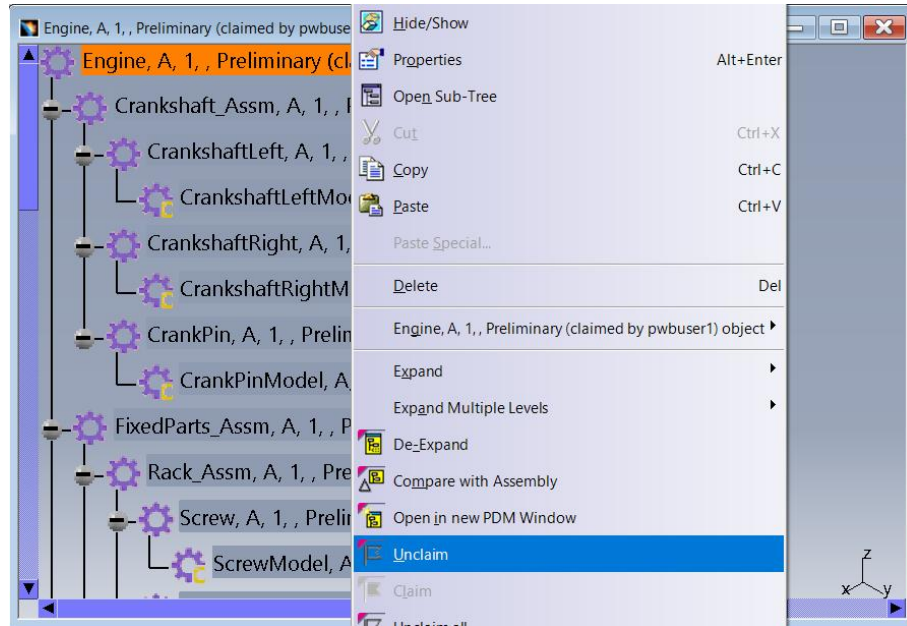

Picture 50: Action “Unclaim”

The selected object and the attached documents will be unclaimed by you (see *Picture 51: Object is unclaimed*).

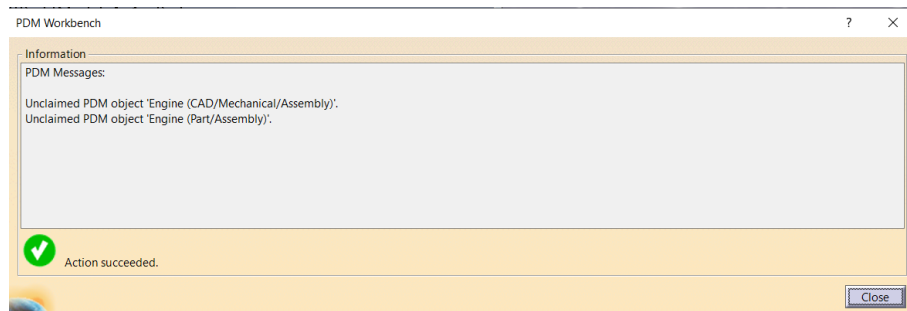

Picture 51: Object is unclaimed

The background color of the unclaimed object changed to blank in the PDM Workbench window (see *Picture 52: Unclaimed object*).

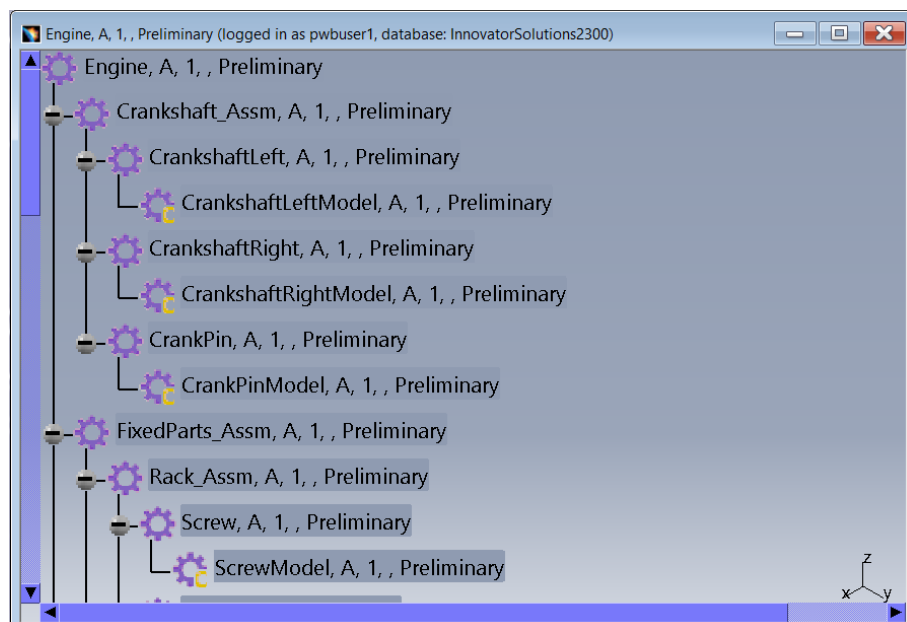

Picture 52: Unclaimed object

The blank background color of the unclaimed object indicates that the object in the PDM system cannot be changed by you.

Unclaim Object in Query Dialog

It is also possible to unclaim the object from the query result list of the "PDM Query" dialog.

In the example you select the object and click on "Unclaim" in the context menu (see *Picture 53: Action "Unclaim" in the query result list*). This action is only active in the context menu when it is possible for the selected object. Otherwise, it will be deactivated in the context menu.

A multi-select of objects is also supported.

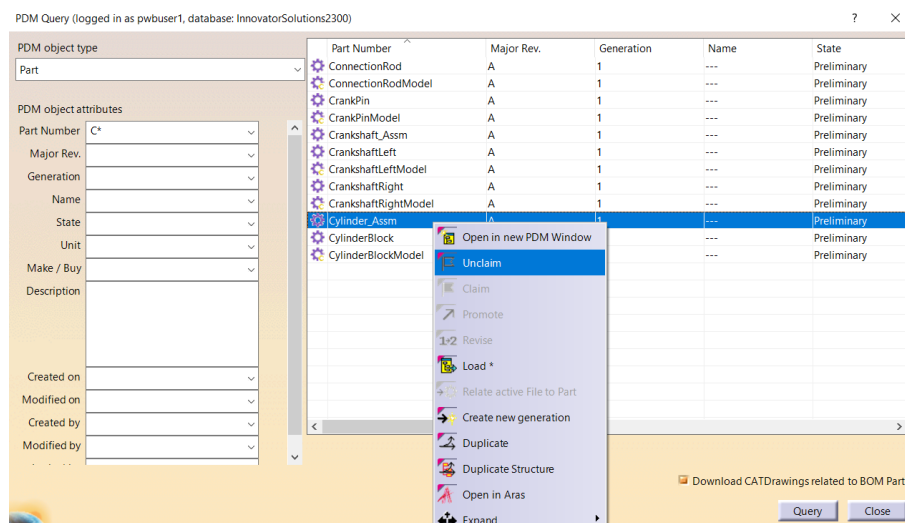

Picture 53: Action "Unclaim" in the query result list

Unclaim Document in CATIA V5 Window

When an object is claimed by you then you can unclaim it in the PDM system to make it available for all other users.

You select the object in the CATIA V5 window and click the right mouse button. In the context menu you select the context action *PDM Workbench* → *Unclaim* (see *Picture 54: Action "Unclaim" in the CATIA V5 window*).

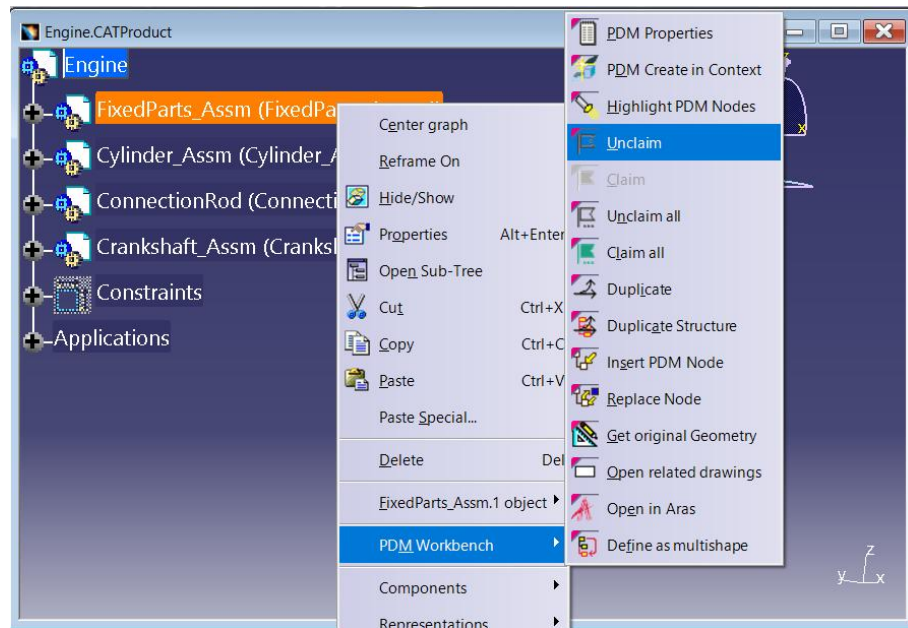

Picture 54: Action “Unclaim” in the CATIA V5 window

For further details of the “Unclaim” dialogs please refer to the chapter *Unclaim Part in PDM Workbench Window*.

The unclaim of a CATPart and CATDrawing as top-level object of the CATIA V5 window cannot be done with the context menu. You have to use the “Unclaim” button within the “PDM Workbench context commands” toolbar. The icons in this toolbar are only repainted (e.g. switch from “Claim” to “Unclaim”) when you newly activate the CATIA V5 window.

A multi-select of objects is also supported.

Claim All

Claim All Parts in PDM Workbench Window

It is possible to claim the selected object and the objects in its substructure.

Select the object and right-click to open the context menu. Choose “Claim All” (see *Picture 55: Action “Claim All”*).

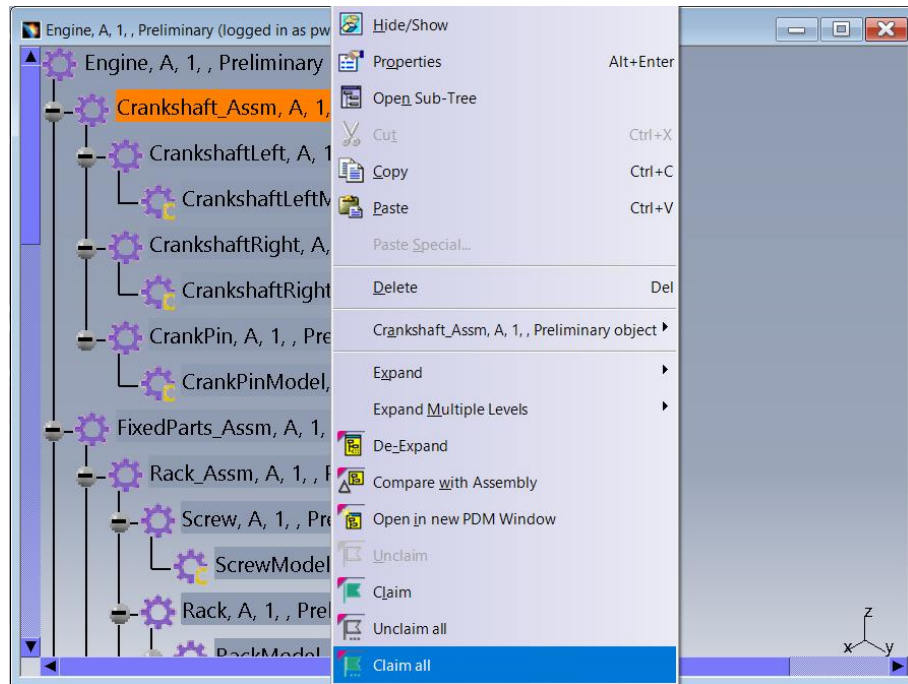

Picture 55: Action “Claim All”

You have to confirm the “Claim All” action of the objects (see *Picture 56: Confirm the “Claim All” action*).

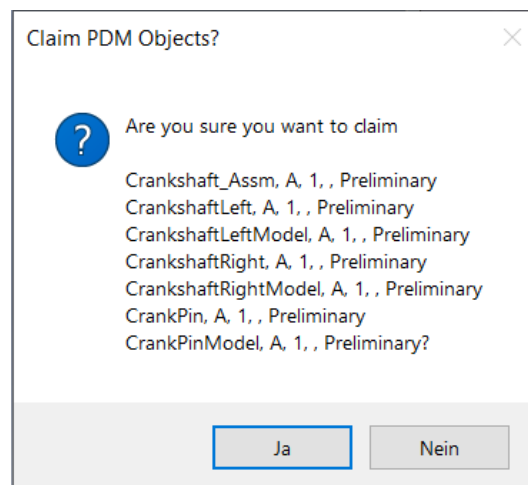

Picture 56: Confirm the “Claim All” action

The objects and the attached documents will be claimed by you (see *Picture 57: Objects are claimed*).



Picture 57: Objects are claimed

The background color of the claimed objects changed to green in the PDM Workbench window (see *Picture 58: Claimed objects*).

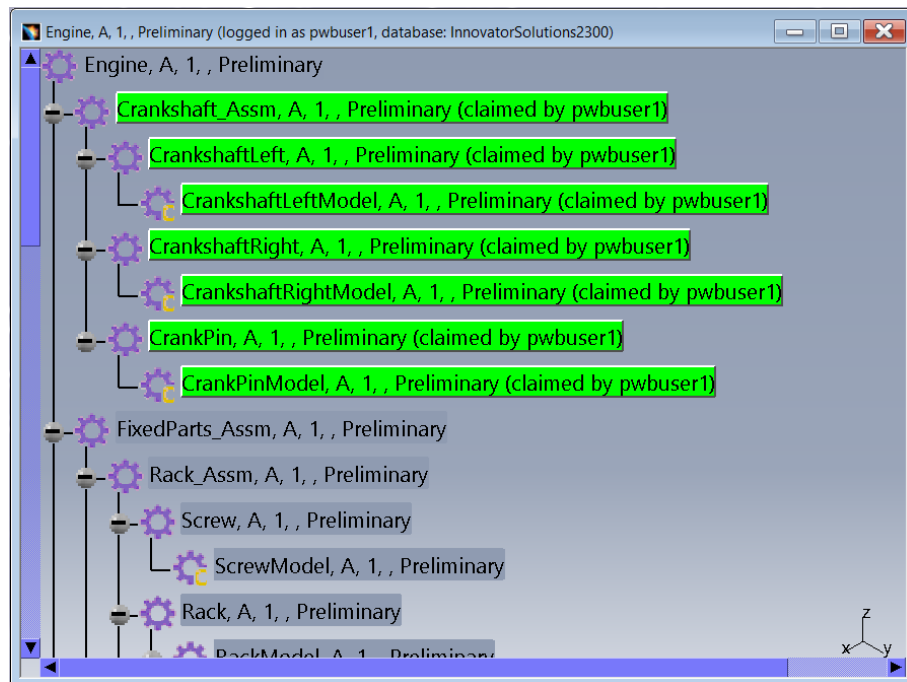

Picture 58: Claimed objects

Claim All Documents in CATIA V5 Window

It is possible to claim the selected object and the objects in its substructure.

You select the object in the CATIA V5 window and click the right mouse button. In the context menu you select the context action *PDM Workbench* → *Claim All* (see *Picture 59: Action “Claim All” in the CATIA V5 window*).

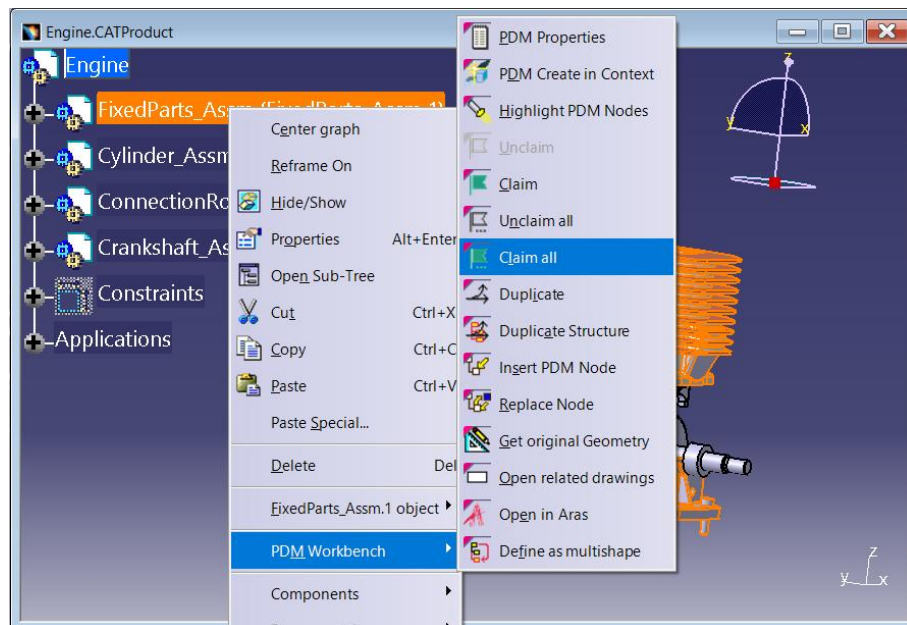

Picture 59: Action “Claim All” in the CATIA V5 window

For further details of the “Claim” dialogs please refer to the chapter *Claim All Parts in PDM Workbench Window*.

A multi-select of objects is also supported.

Unclaim All

Unclaim All Parts in PDM Workbench Window

It is possible to unclaim the selected object and the objects in its substructure.

Select the object and right-click to open the context menu. Choose “Unclaim All” (see *Picture 60: Action “Unclaim All”*).

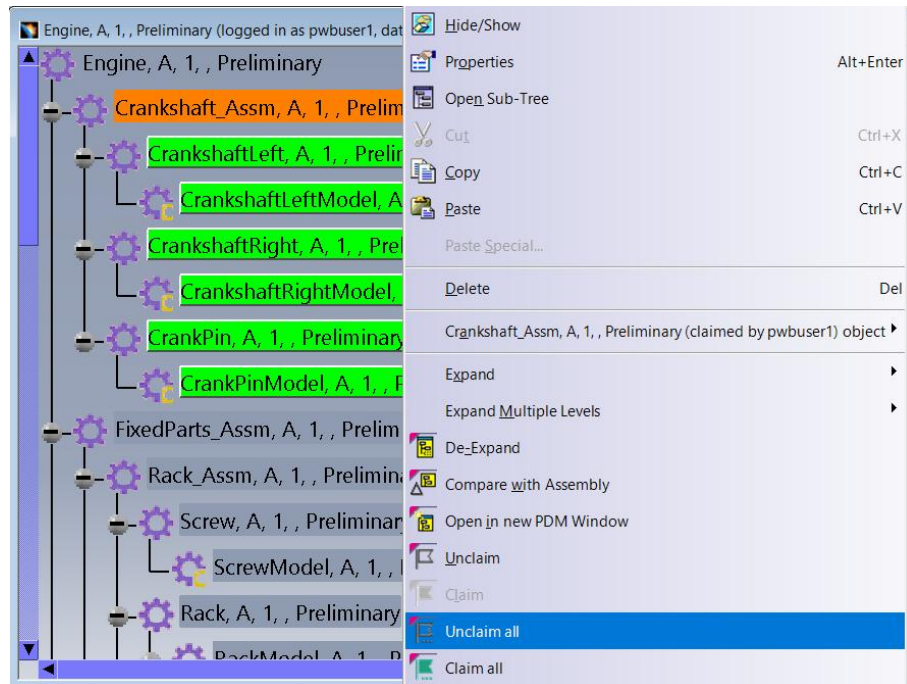

Picture 60: Action “Unclaim All”

You have to confirm the “Unclaim All” action of the objects (see *Picture 61: Confirm the “Unclaim All” action*).

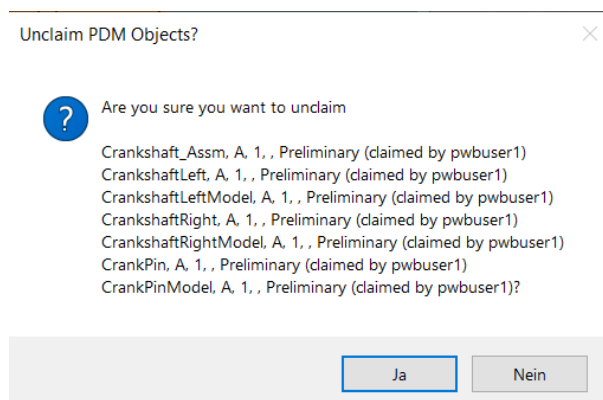

Picture 61: Confirm the “Unclaim All” action

The objects and the attached documents will be unclaimed by you (see *Picture 62: Objects are unclaimed*).

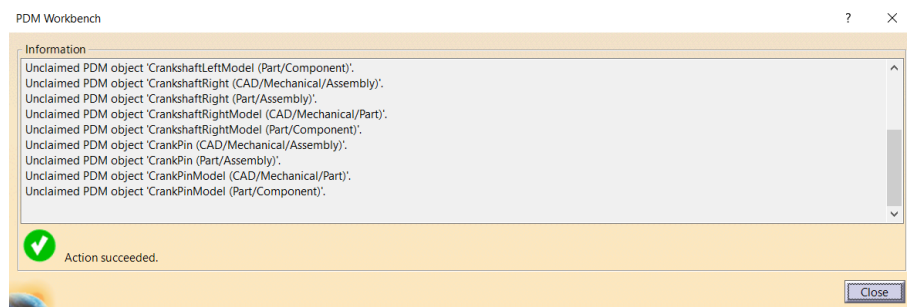

Picture 62: Objects are unclaimed

The background color of the unclaimed objects changed to blank in the PDM Workbench window (see *Picture 63: Unclaimed objects*).

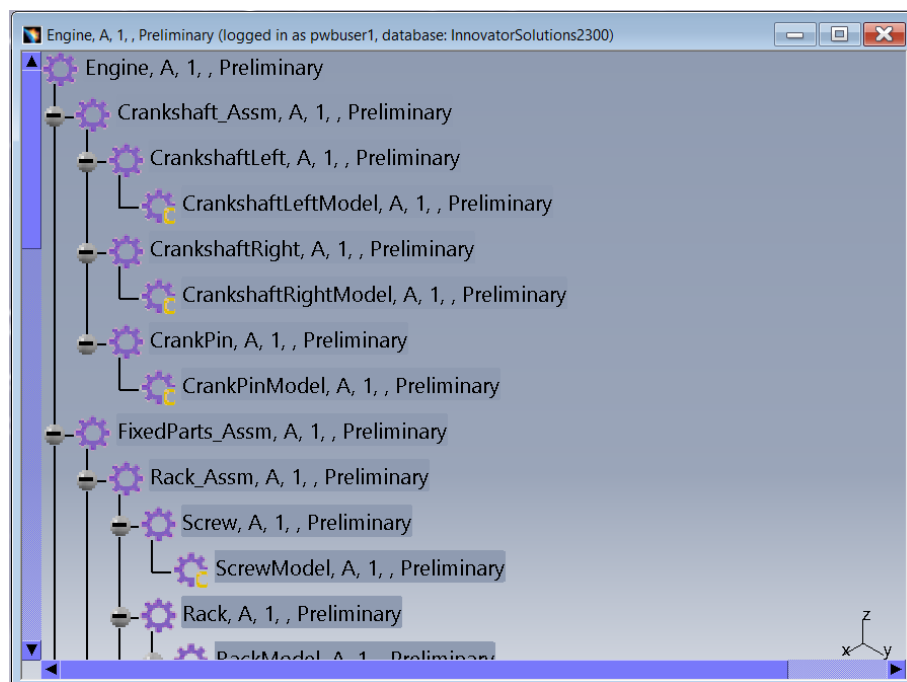

Picture 63: Unclaimed objects

Unclaim All Documents in CATIA V5 Window

When an object is claimed by you then you can unclaim it in the PDM system to make it available for all other users. It is possible to unclaim the selected object and the objects in its substructure.

You select the object in the CATIA V5 window and click the right mouse button. In the context menu you select the context action *PDM Workbench* → *Unclaim All* (see *Picture 64: Action "Unclaim All" in the CATIA V5 window*).

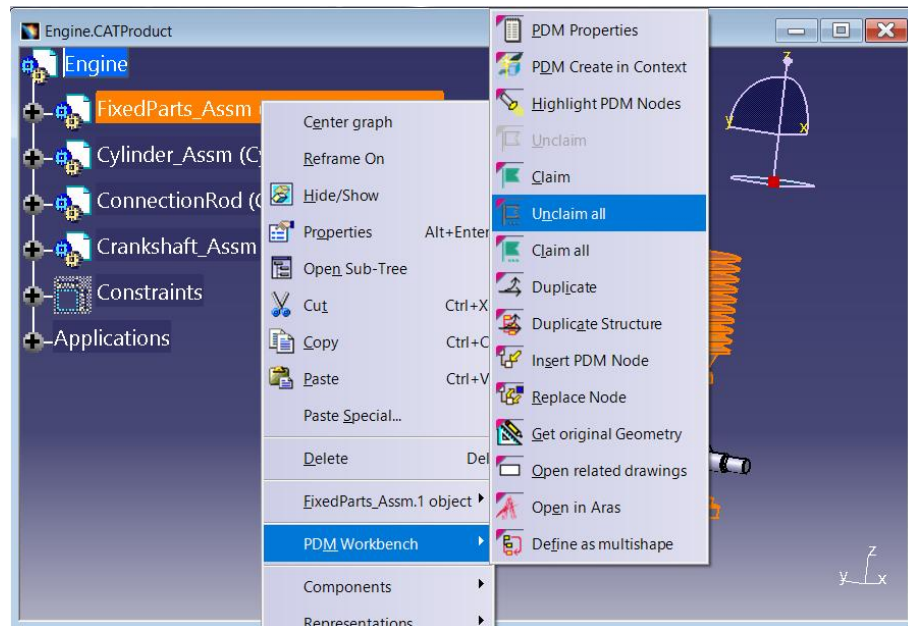

Picture 64: Action “Unclaim All” in the CATIA V5 window

For further details of the “Unclaim All” dialogs please refer to the chapter *Unclaim All Parts in PDM Workbench Window*.

A multi-select of objects is also supported.

Warning when the User wants to unclaim modified Files

There is a functionality which warns the user when he is about to unclaim CATIA files that are modified in the session:

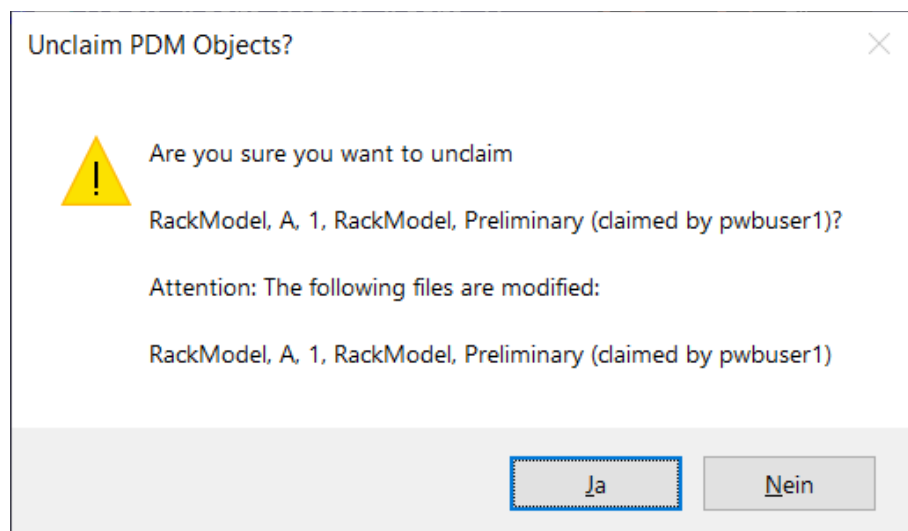

Picture 65: Warning Dialog at Unclaim

Promote

The PDM objects can be promoted.

You select the object in the PDM Workbench window and click the right mouse button. In the context menu you select the “Promote” context action (see *Picture 66: Action “Promote”*).

The part and the document have to be unclaimed in order to be promoted.

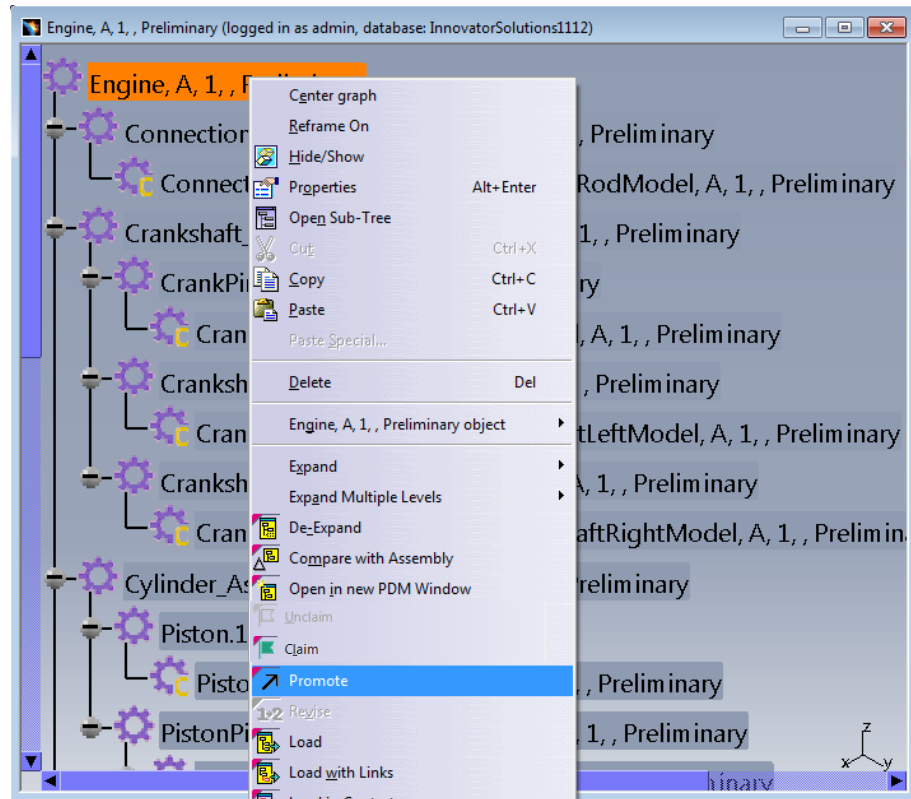

Picture 66: Action “Promote”

You will be asked if you really want to promote the objects. Please confirm with "Yes" (see *Picture 67: Confirm the “Promote” action*).

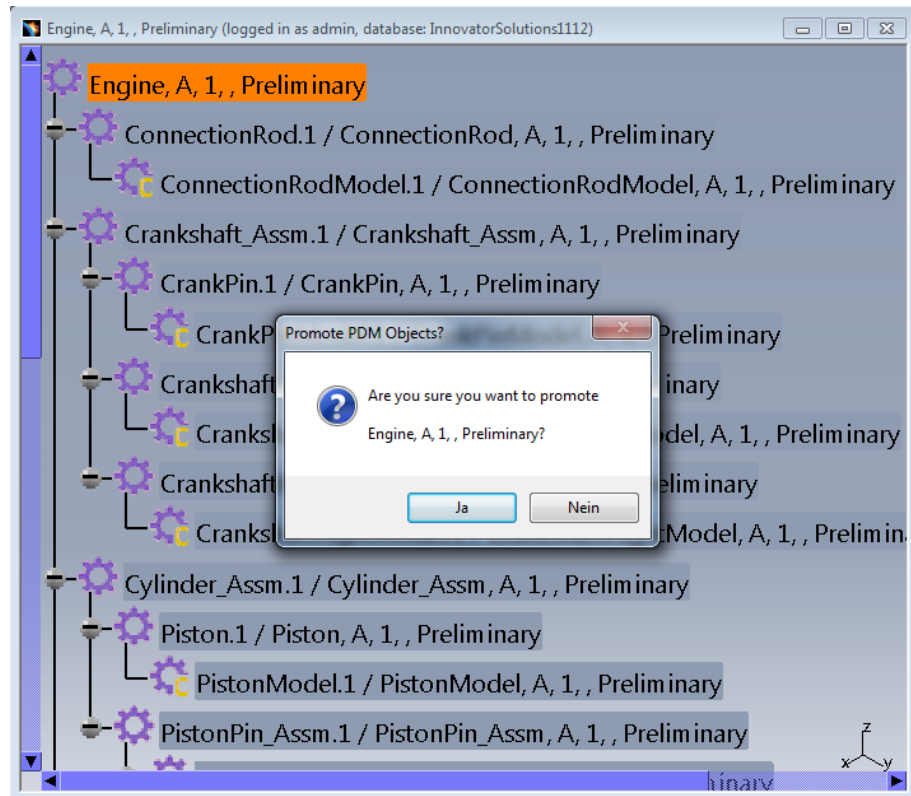

Picture 67: Confirm the "Promote" action

The selected object and the attached documents will be promoted. In this example from the life cycle state "Preliminary" to the state "In Review" (see *Picture 68: Object is promoted*).

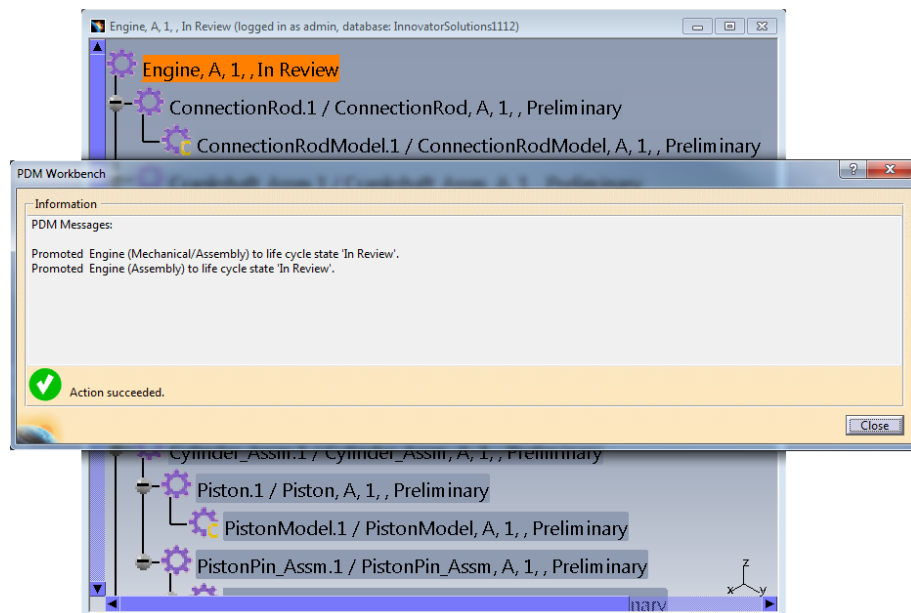

Picture 68: Object is promoted

Revise

The PDM objects can be revised if the item is in released mode.

You select the object in the PDM Workbench window and click the right mouse button. In the context menu you select the "Revise" context action (see *Picture 69: Action "Revise"*). The part and the document have to be released in order to be revised.

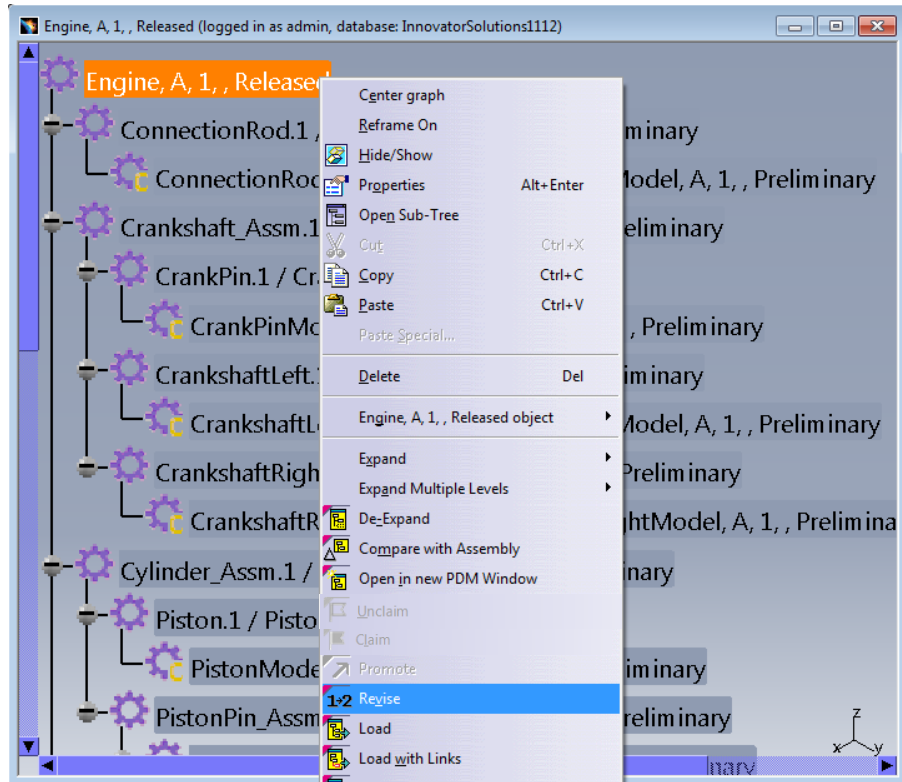

Picture 69: Action "Revise"

You will be asked if you really want to revise the object. Please confirm with "Yes" (see *Picture 70: Confirm the "Revise" action*).

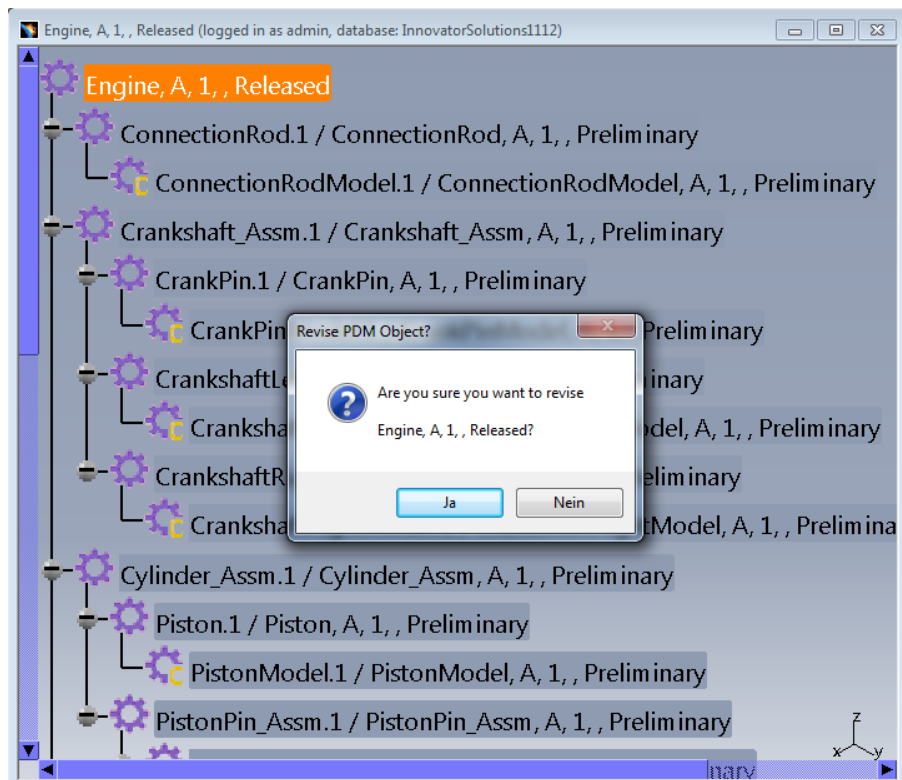

Picture 70: Confirm the "Revise" action

The selected object will be revised (see *Picture 71: Object is revised*).

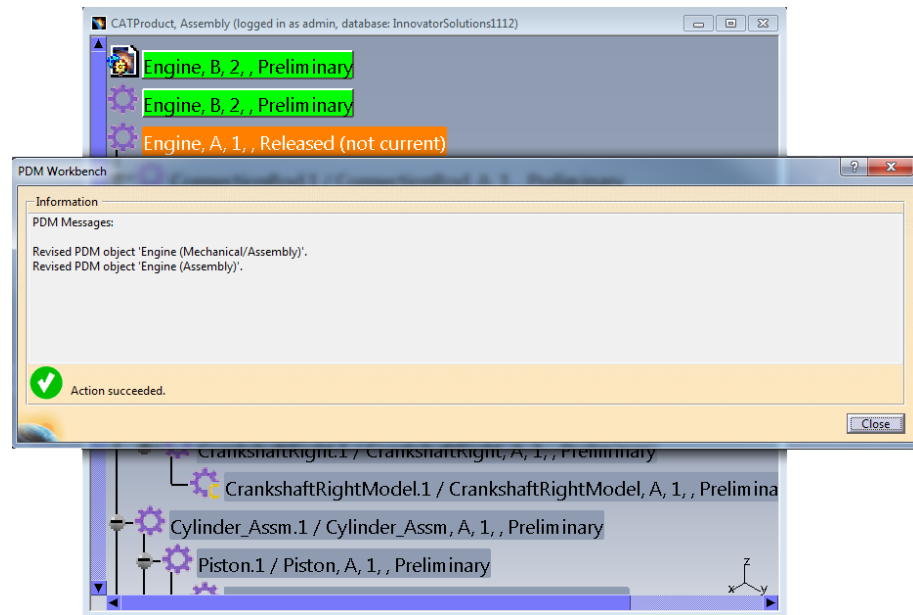

Picture 71: Object is revised

The new object was added in the window on the top.

Update Structure Relations

This functionality is only available for the document data model.

You have the possibility to update an object with a new revision of an already used object.

In this example the document "FixedParts_Assm" has been revised from "A" to "B". The revision "A" was already used by the document "Engine".

You have to select the CATIA Product "Engine" and choose "Update structure relations" (see *Picture 72: Action "Update structure relations"*).

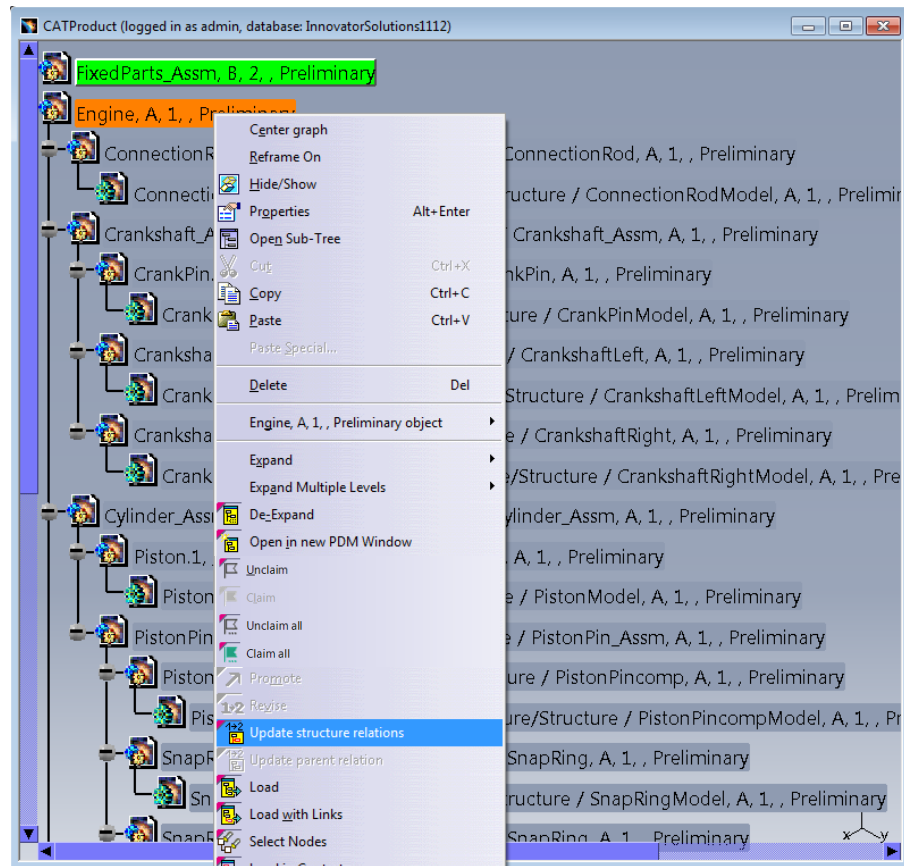

Picture 72: Action “Update structure relations”

Now the new revisions of the used objects are related to this object and the relations to the old revisions are deleted.

You can see that the revision "B" of the "FixedParts_Asm" is used by the "Engine" now (see *Picture 73: Structure relations*).

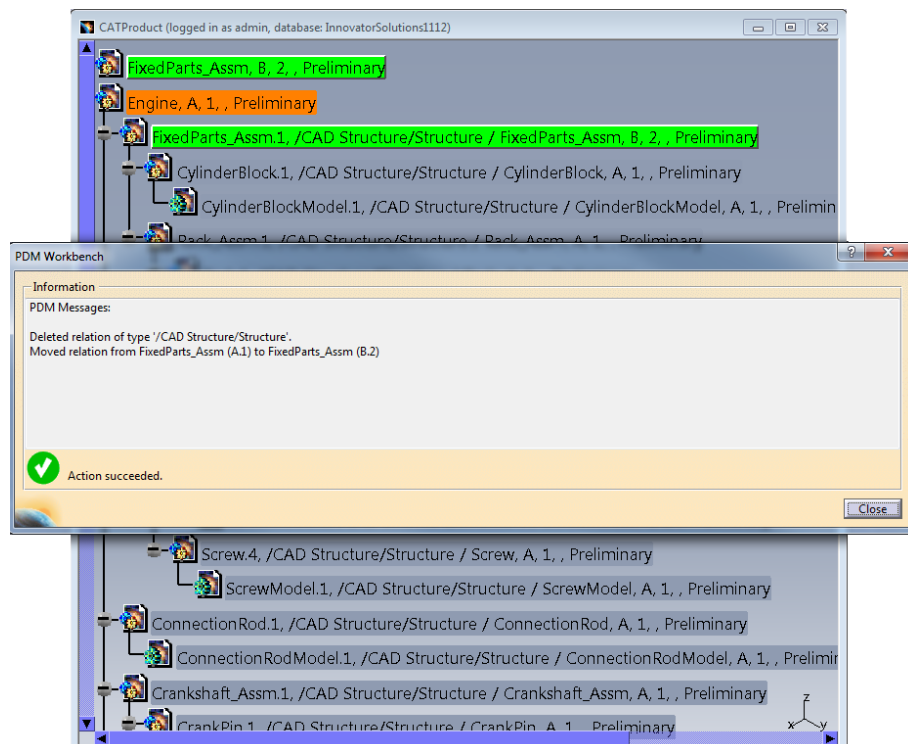

Picture 73: Structure relations are updated

Update Parent Relation

This functionality is only available for the CAD Document Structure Data Model.

Like “Update structure relations”, this functionality updates the structure relations of a used document to the latest generation of that document. The difference is that in this case, only the selected child node (all instances of the document) is updated, not all the direct child nodes of the parent document.

The context action is only available for child nodes in a PDM structure, not for the root node (see *Picture 74: Action “Update parent relation”*).

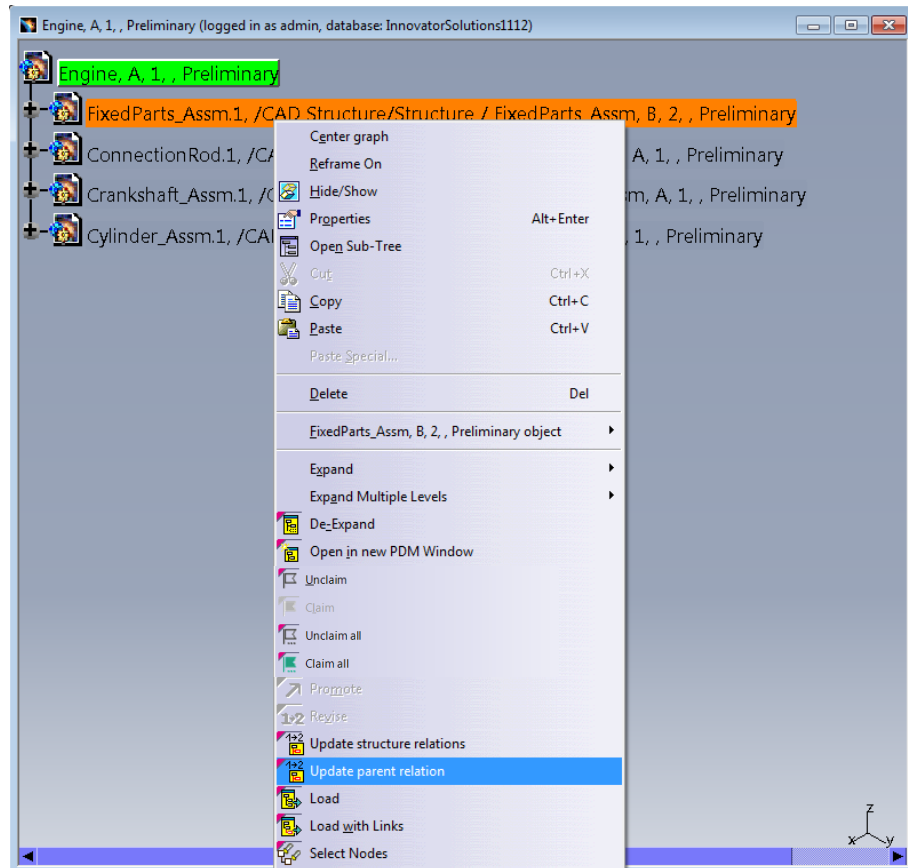

Picture 74: Action “Update parent relation”

You have to select the required generation (see *Picture 75: Action “Update parent relation” – select version*).

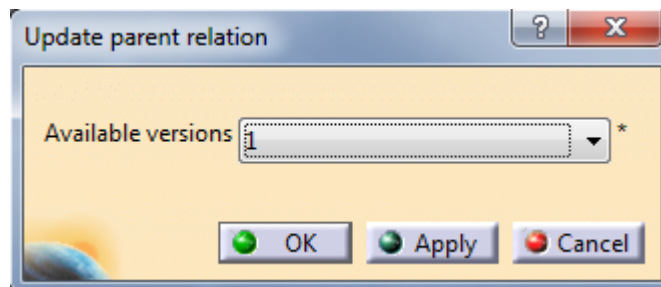

Picture 75: Action “Update parent relation” – select version

The relation has been updated (see *Picture 76: Parent relation is updated*).

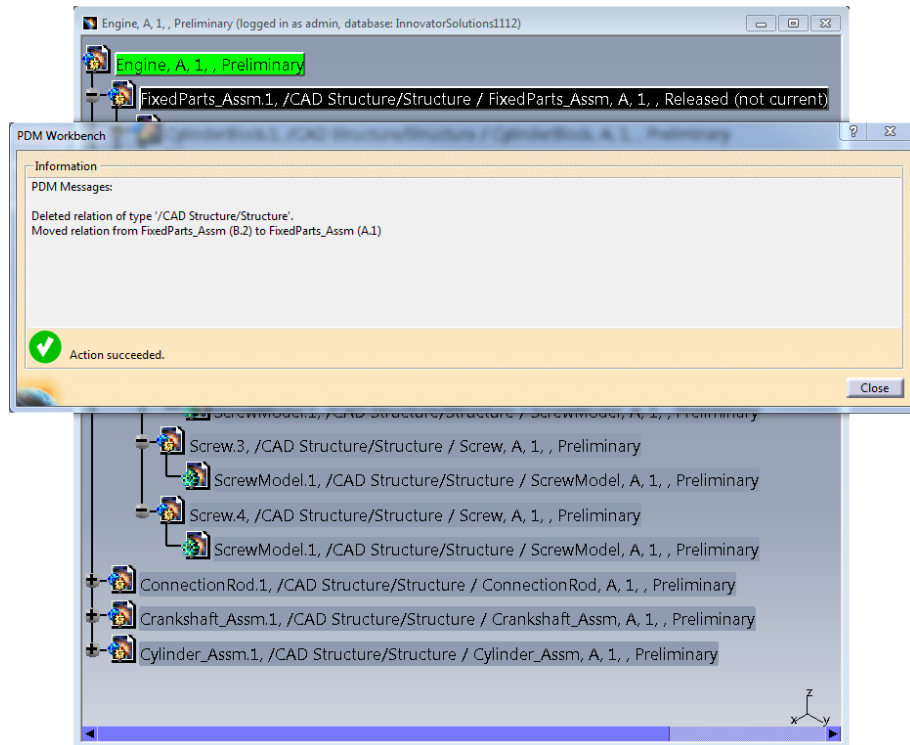

Picture 76: Parent relation is updated

The structure relations will have to be expanded again to show the current status (see *Picture 77: Updated structure relation*):

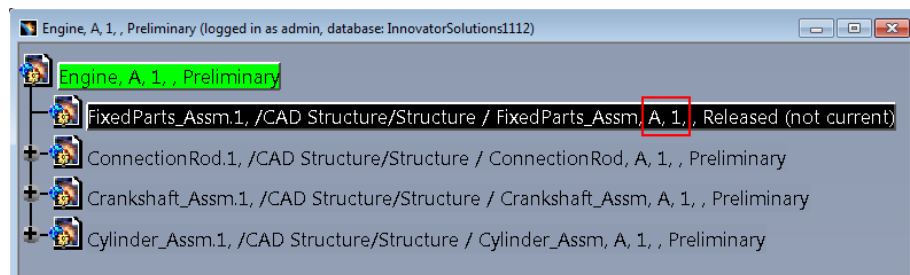

Picture 77: Updated structure relation

Delete

Existing PDM objects can be deleted from the PDM Workbench. Delete is a set based operation, which means multiple objects can be deleted in one action.

Select objects in the PDM Workbench window and from the contextual menu choose "Delete" (see *Picture 78: Action "Delete"*).

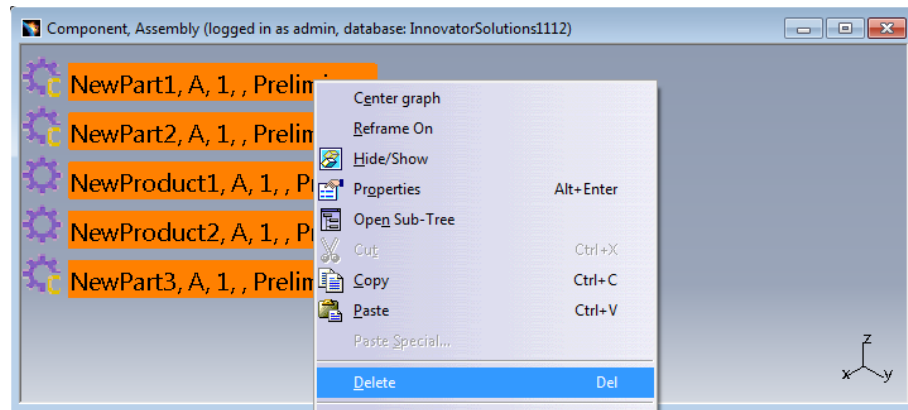

Picture 78: Action "Delete"

A confirmation message box is displayed listing the objects which will be deleted (see *Picture 79: Confirm the "Delete" action*). When you confirm this dialog with "Yes" the objects will be deleted.

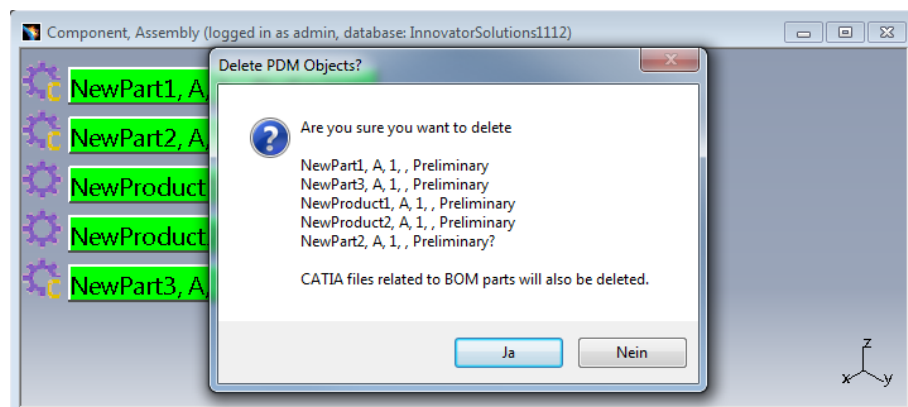

Picture 79: Confirm the "Delete" action

The operation result dialog is displayed containing error or success messages (see *Picture 80: Objects are deleted*).

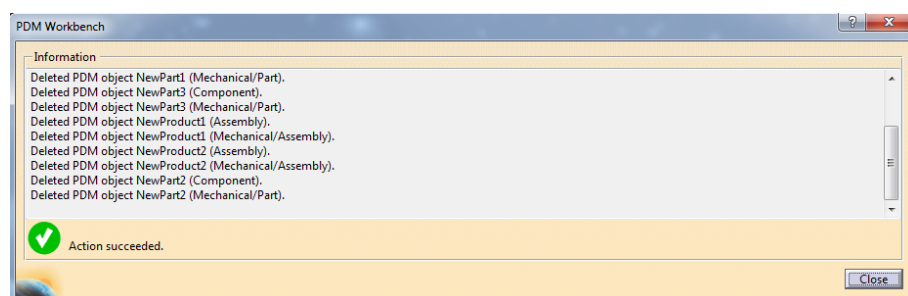

Picture 80: Objects are deleted

When you delete a part object the attached documents will be deleted, too.

Create new Version

A new generation of a CAD Document can be created by clicking on the "Create new version" context menu in the PDM window (see *Picture 81: Action "Create new version"*).

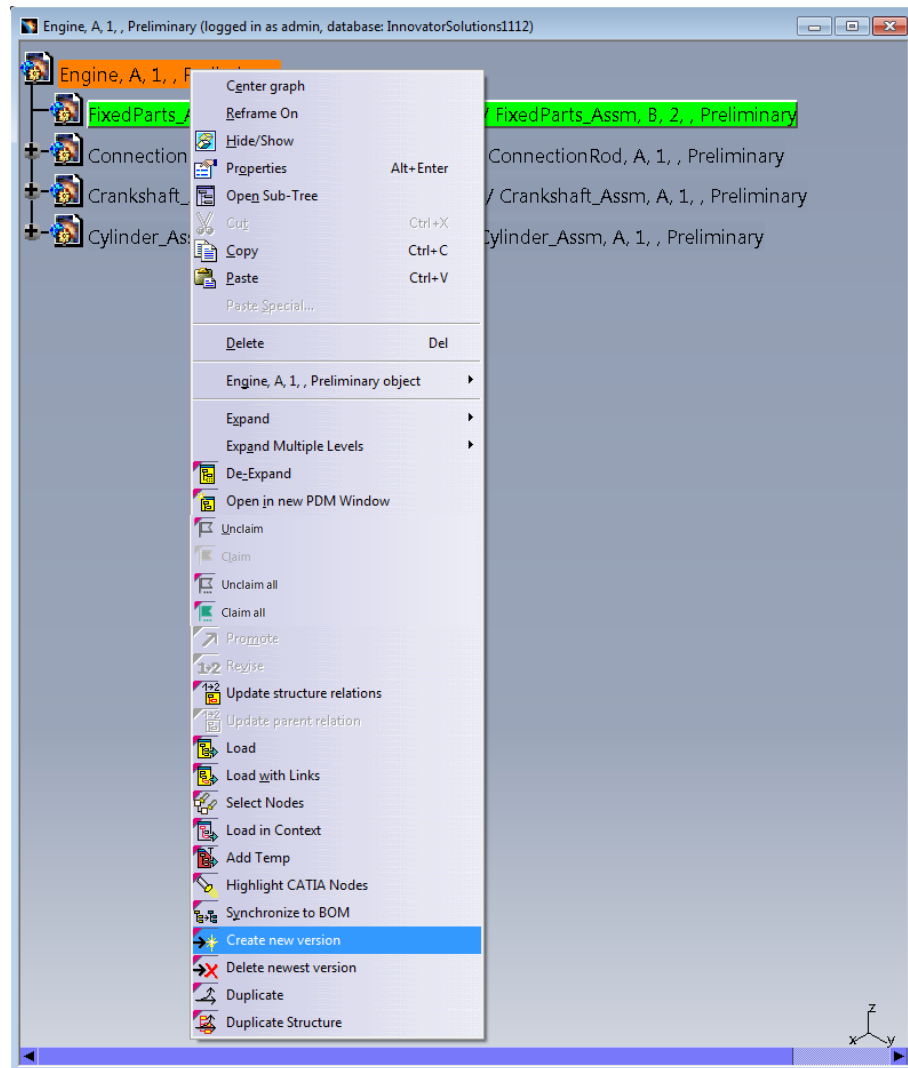

Picture 81: Action "Create new version"

Delete newest Version

You can delete the newest generation of the file when there exist more than one generation for the file and you see that you do not need this generation anymore because you want to design the geometry a different way.

You have to select the last generation of the document and click on the right mouse button. The context menu will be opened. There you select "Delete newest version" (see *Picture 82: Action "Delete newest version"*).

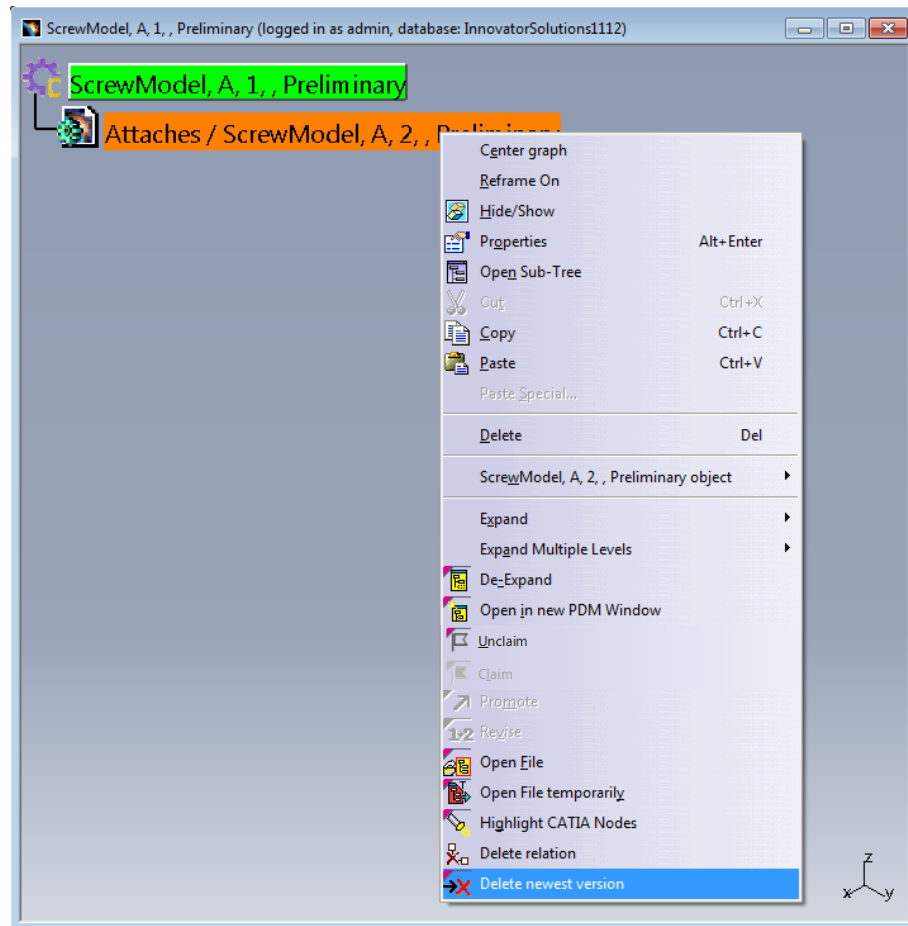

Picture 82: Action "Delete newest version"

Then you are asked to confirm the delete of the newest generation. You have to click the "Yes" button (see *Picture 83: Confirm the "Delete newest version"*).

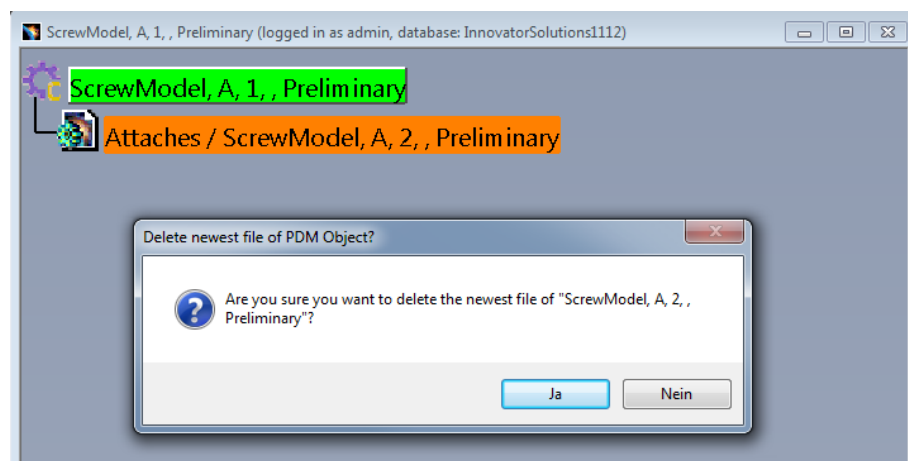

Picture 83: Confirm the "Delete newest version" action

The newest generation will be deleted. The document will be removed from the window (see *Picture 84: Newest generation object is deleted*).

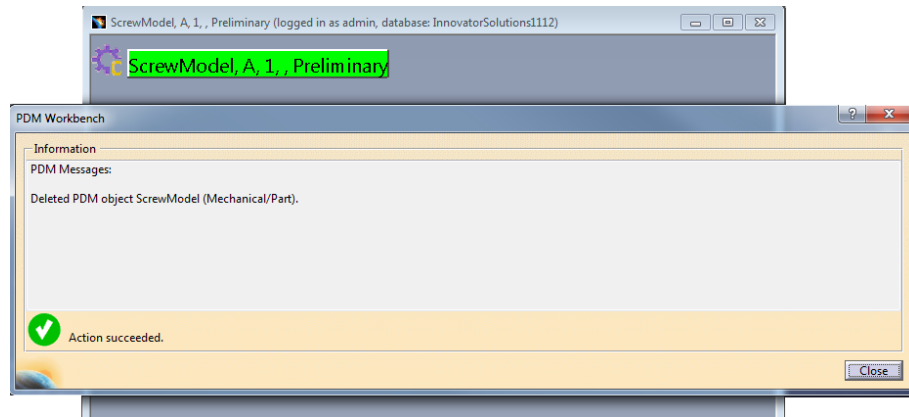

Picture 84: Newest generation object is deleted

You have to re-expand the document in order to see the document that is attached to the component (see *Picture 85: Re-Expand of the document*).

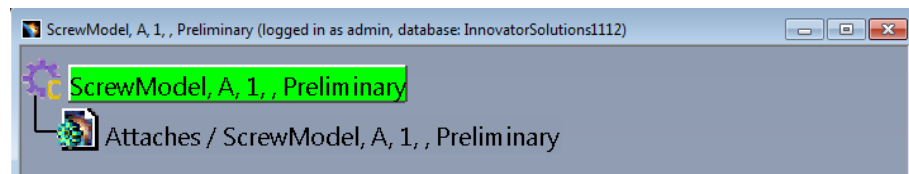

Picture 85: Re-Expand of the document

Only one new Generation of a CAD Document per “Claim” Action

It can be configured what only one new generation of a CAD Document will be created for a claimed document. This new generation will be created at the first update after the claim. Further updates will overwrite the newly created generation. If a new generation of the CAD Document should be created explicitly then the user has to unclaim the CAD Document and claim it again before performing the next update.

CAD Document generations which are read-only, for example because they are released or frozen can be claimed if they are current. In this case the new generation will be created by the “Claim” process, and the first update will not create another new generation.

If an already claimed CAD Document becomes read-only later, then a new generation of the CAD Document will be created at update, since the claimed generation cannot be overwritten.

Unlink and Delete newest Version

This function is a combination of “delete Part CAD relation” and “delete newest CAD version”.

You have to select the last generation of the document and click on the right mouse button. The context menu will be opened. There you select “Unlink and delete newest version” (see *Picture 86: Action “Unlink and delete newest version”*).

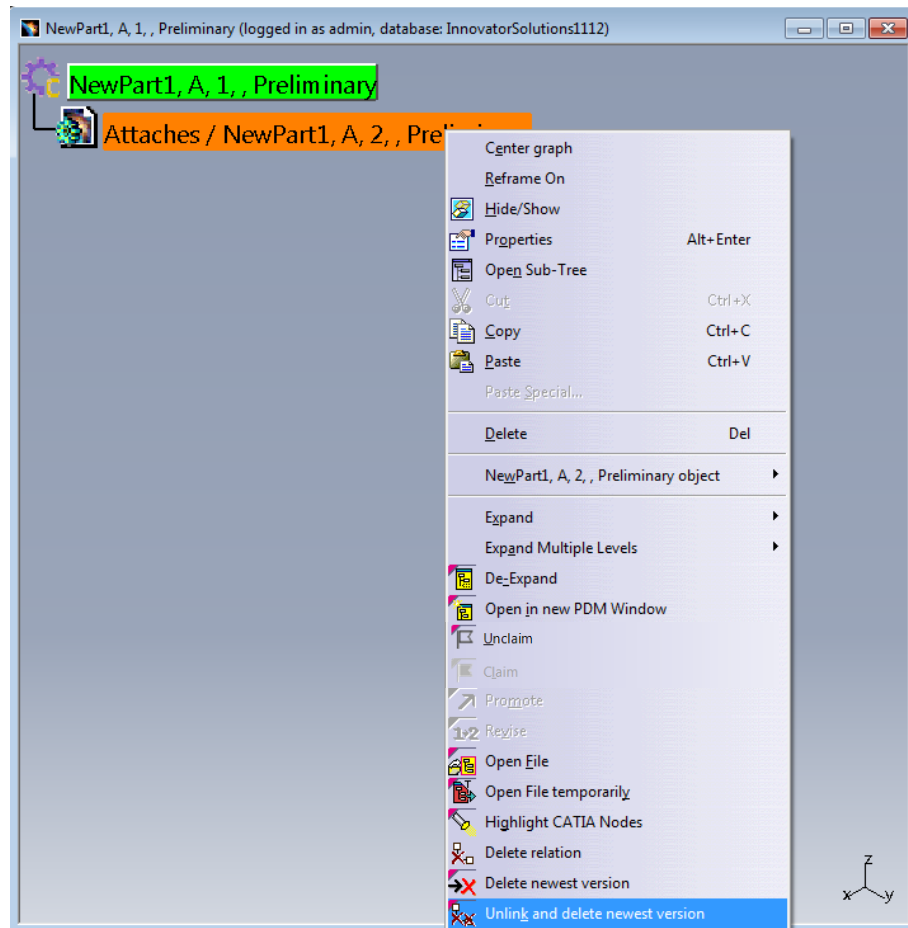

Picture 86: Action “Unlink and delete newest version”

Then you are asked to confirm the delete of the newest generation. You have to click the "Yes" button (see *Picture 87: Confirm the “Unlink and delete newest version” action*).

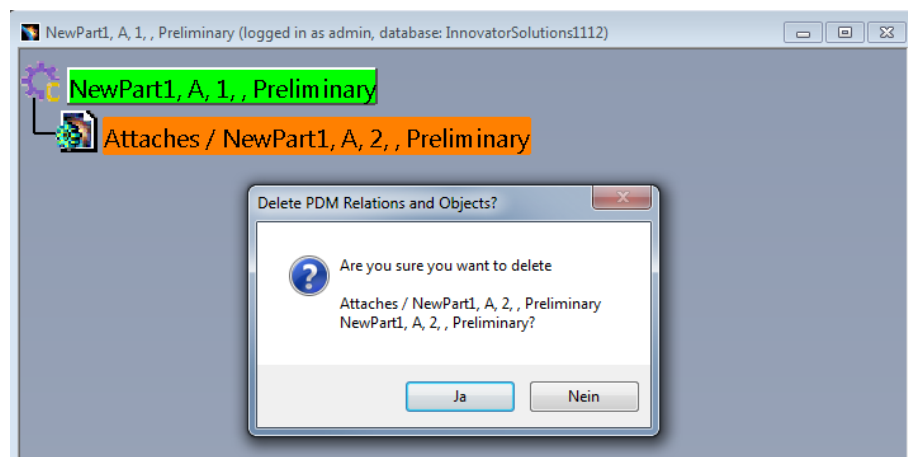

Picture 87: Confirm the “Unlink and delete newest version” action

The newest generation will be unlinked and deleted. The document will be removed from the window (see *Picture 88: Newest generation object is unlinked and deleted*).

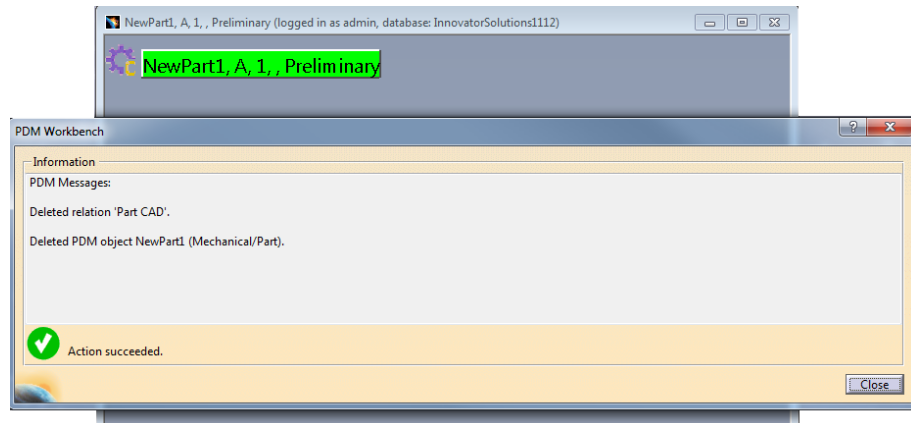

Picture 88: Newest generation object is unlinked and deleted

No document is related to the part. You can continue creating new geometry for it.

Open File

This functionality is only available for the CAD Document Structure Data Model.

You can open a single CATIA V5 Drawing file existing in the PDM database with the PDM Workbench in the native CATIA V5 window.

You can also open a single CATIA V5 Part or CATIA V5 Product file existing in the PDM database in the native CATIA V5 window.

To open the file in CATIA V5 you select the PDM file object in the PDM Workbench window and click the right mouse button to open the context menu. There you select the context action "Open File" (see *Picture 89: Action "Open File"*).

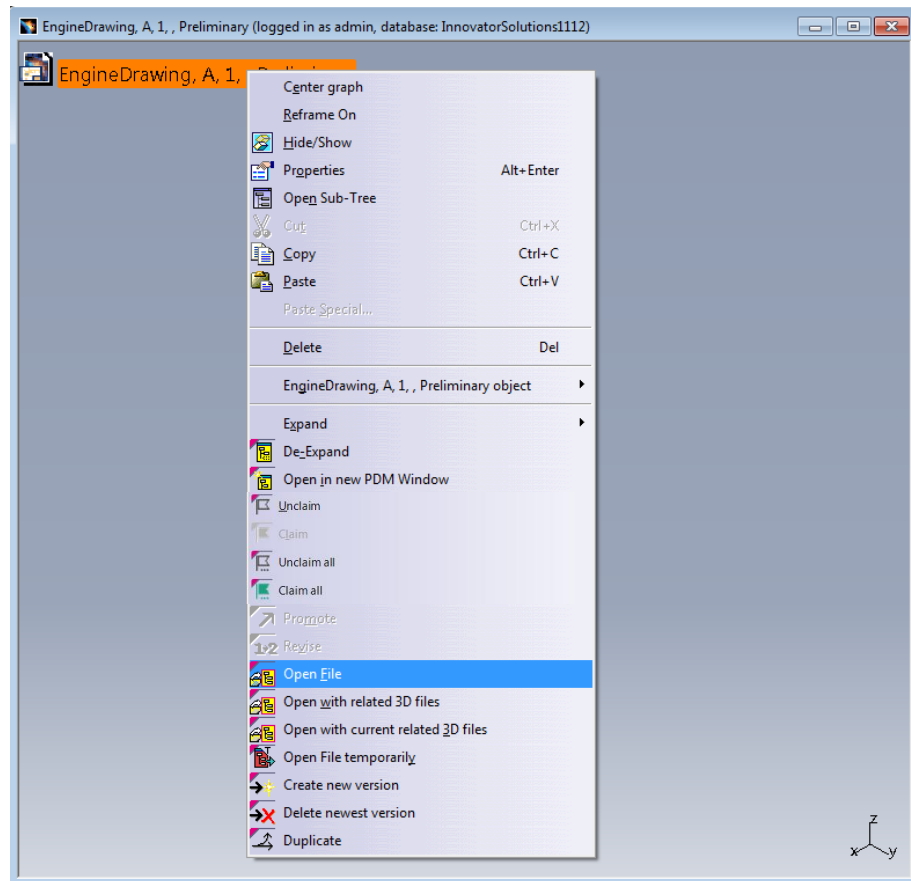

Picture 89: Action “Open File”

The PDM Workbench downloads the required CAD file to the client’s special PDM Workbench exchange map. You can watch the download progress on the “Open File” progress bar (see *Picture 90: Open File – progress bar*).

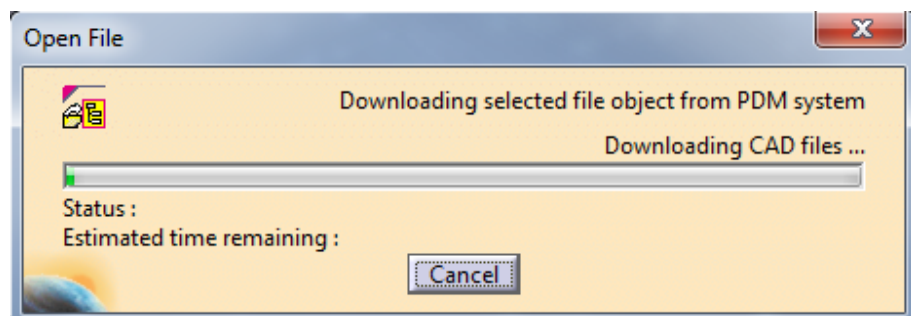

Picture 90: Open File – progress bar

The geometry opens in its corresponding CATIA V5 native window (see *Picture 91: Split window after Open File – PDM Workbench node and CATIA drawing*).

In the above window (PDM Workbench window) you see the selected PDM file object. The window on the bottom shows the loaded CATDrawing.

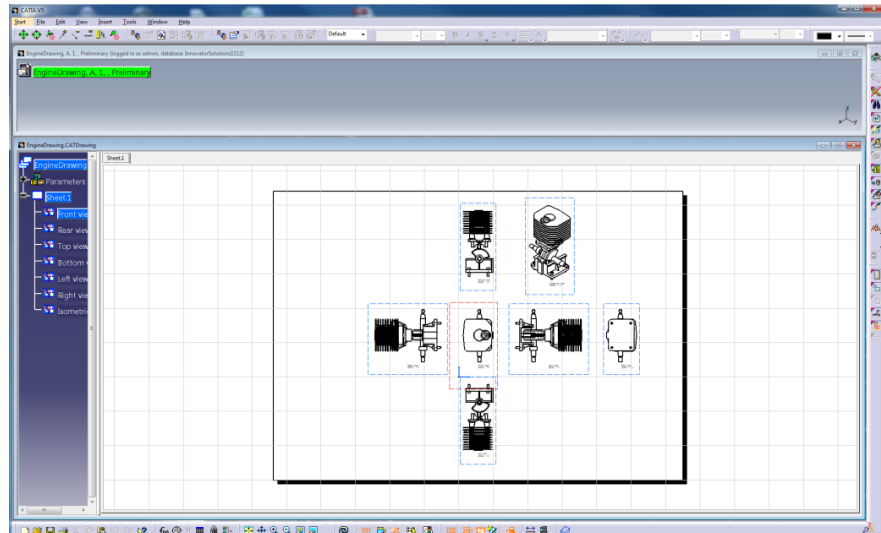

Picture 91: Split window after Open File – PDM Workbench node and CATIA drawing

Open File Temporary

The action "Open File Temporary" allows you to visualize a temporary file of a different generation together with the working generation.

In the first step you load the current generation of the file. In this example you open the generation "2" of the "ScrewModel".

You select the object and click on the right mouse button. In the context menu you select the action "Open File" (see *Picture 92: Action "Open File"*).

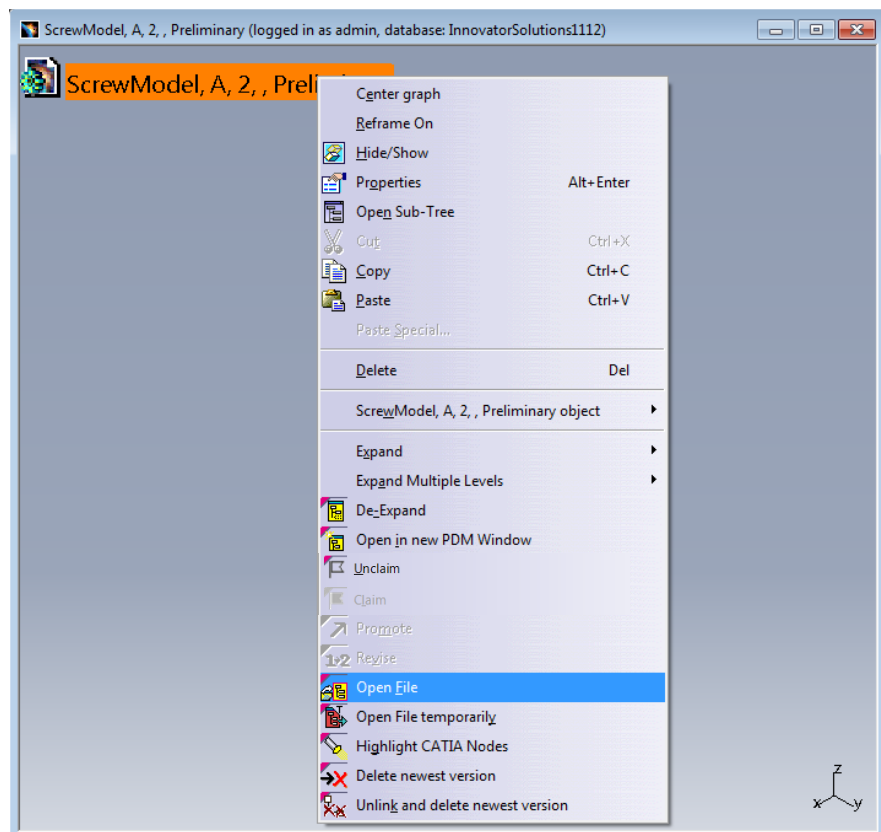

Picture 92: Action "Open File"

The current generation of the file is loaded in CATIA V5, now (see *Picture 93: Current file*).

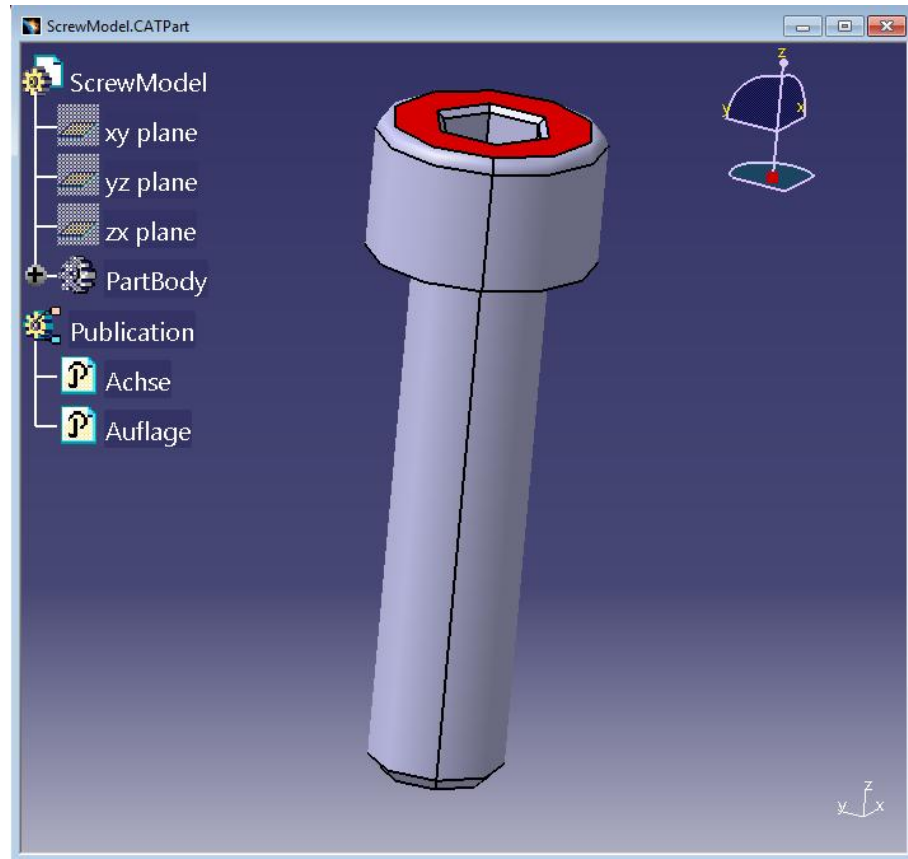

Picture 93: Current file

Then you query for a different generation (in this case generation "1") and open the file temporary.

You select the object and click on the right mouse button. In the context menu you select the action "Open File Temporary" (see *Picture 94: Action "Open File Temporary"*).

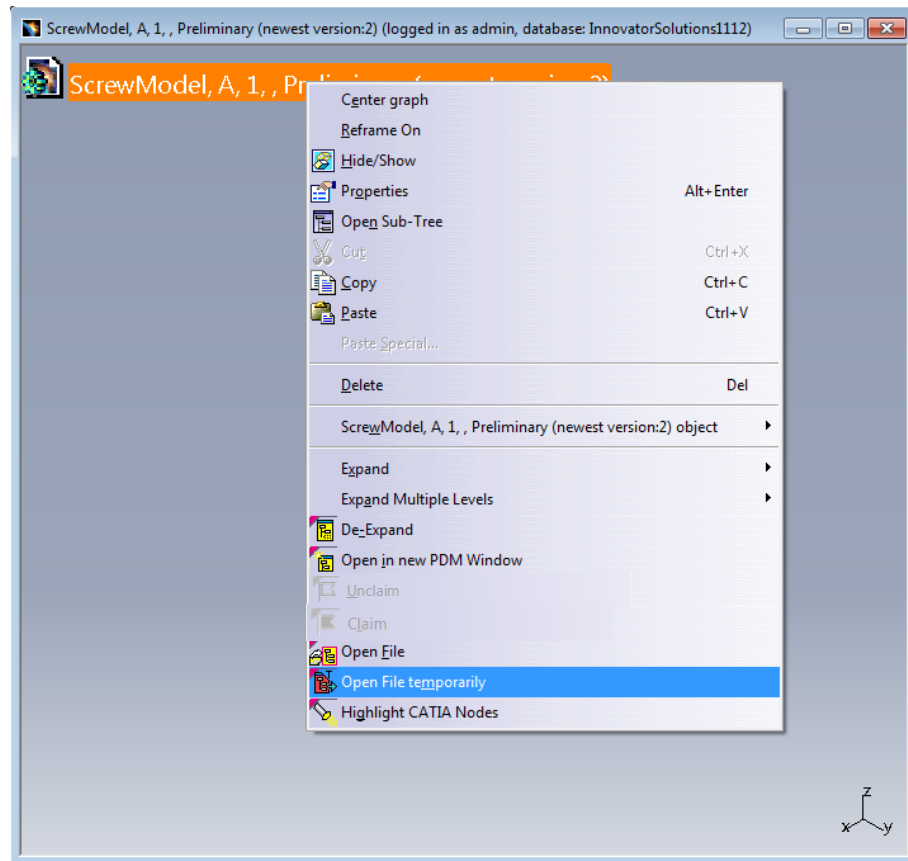

Picture 94: Action “Open File Temporary”

The generation "1" of the file is opened temporarily in CATIA V5 (see *Picture 95: Temporarily opened file*).

The Part Number and the File Name of the temporarily opened geometry are prefixed with “TMP#_”, where “#” is a counter in CATIA V5, beginning with 1. Every action "Open File Temporary" will increase the counter. This prefix is customisable by the customer. For details please refer to the *PDM Workbench Installation & Administration Manual*.

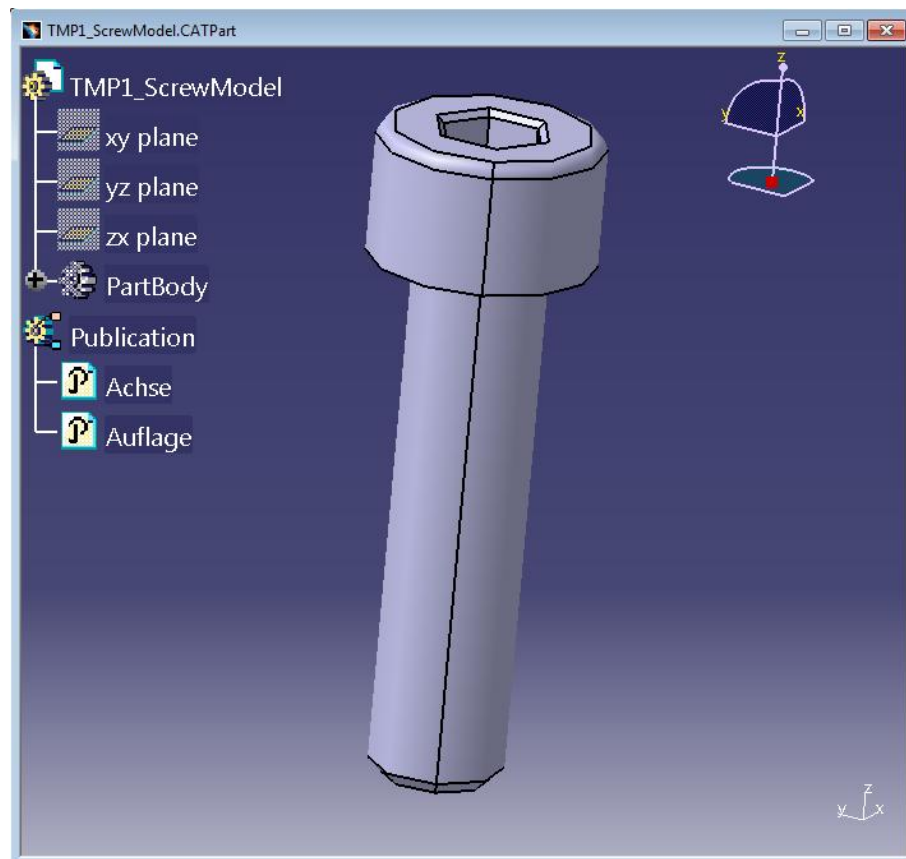

Picture 95: Temporarily opened file

Now you can compare the both generations of the file.

Load

It is possible to load geometry corresponding to an expanded PDM structure into a native CATIA V5 window in order to work on it, e.g. perform geometric transformations, geometry changes and so on.

To load the geometry in CATIA V5 you select the root PDM object wherefrom downward you want to get the geometry and click the right mouse button to open the context menu and you select the context action "Load" (see *Picture 96: Action "Load"*).

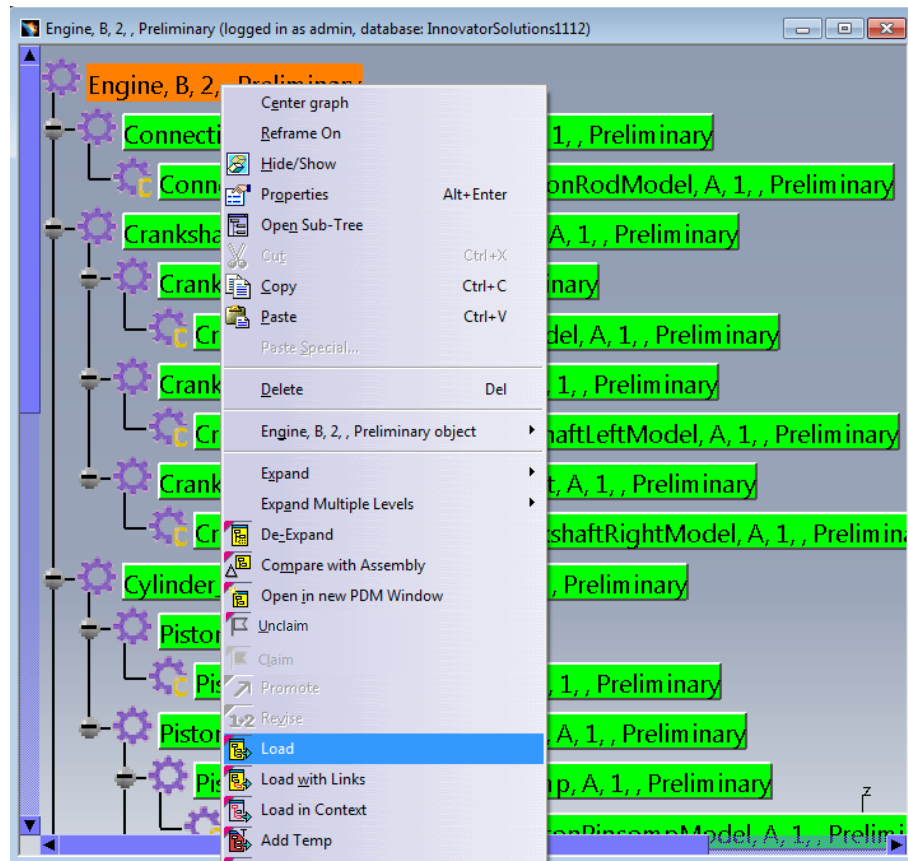

Picture 96: Action “Load”

The PDM Workbench downloads the corresponding CAD files (CATParts, CATProducts, and CATDrawings) to the client’s PDM Workbench exchange directory. The download progress is indicated by the “Load” progress bar (see *Picture 97: Load - progress bar*).

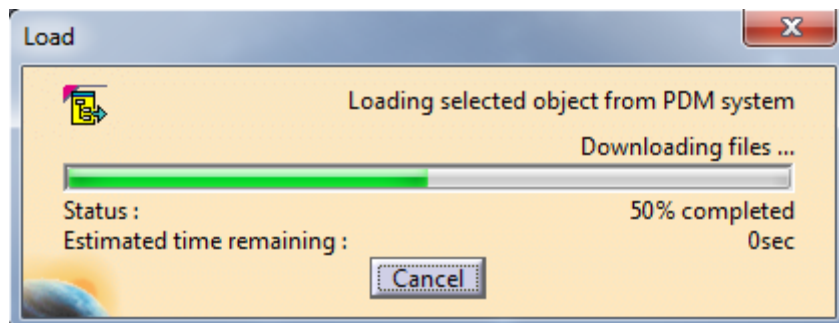

Picture 97: Load - progress bar

The geometry downloaded opens in a CATIA V5 native window (see *Picture 98: Split window after Load – PDM Workbench and CATIA V5 nodes*).

In the left window (PDM Workbench window) you see the expanded PDM structure wherefrom you opened the CATIA V5 native window presenting the geometry on the right. In the right window you see the loaded geometry.

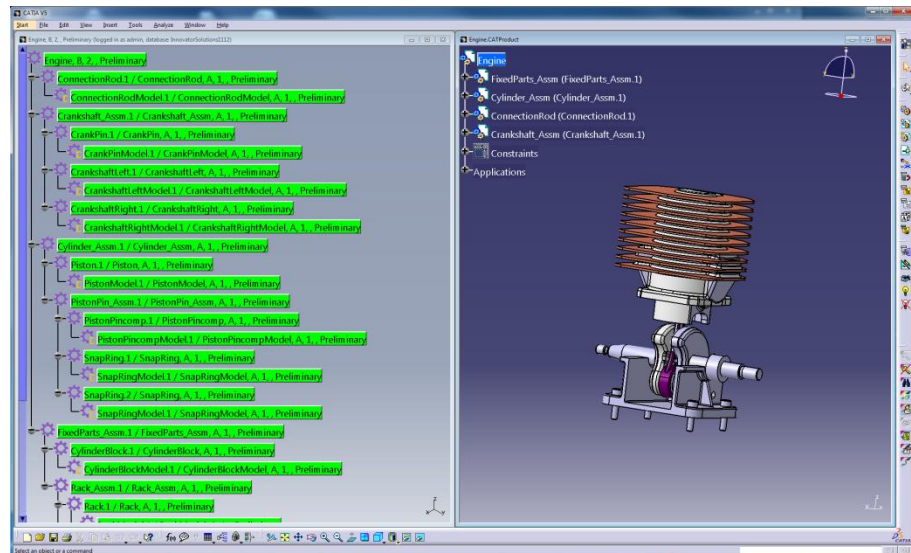

Picture 98: Split window after Load – PDM Workbench and CATIA V5 nodes

Additional Options for “Loading PDM Structures”

If not the complete structure is loaded, that is, if parts of the structure are de-expanded or filtered out due to a specific configuration, the missing CATPart and CATProduct nodes can be displayed as deactivated, or as being in no-show. Conversely, nodes that are loaded can be set to active, or being in “show” mode. It is also possible to not change CATProduct or CATPart nodes with respect to their activate/deactivate and show/no-show status at all.

Depending on the way of working, different settings can make sense:

- **Enable Activate/Deactivate:**
This option should be used if the designer works with Hide/Show. This way the Hide/Show status the designer explicitly sets will not be changed when the structure is loaded.
- **Enable Hide/Show:**
This option should be used if the designer works with Activate/Deactivate.
- **No Change:**
This option should be used if the designer works with both Activate/Deactivate and Hide/Show.

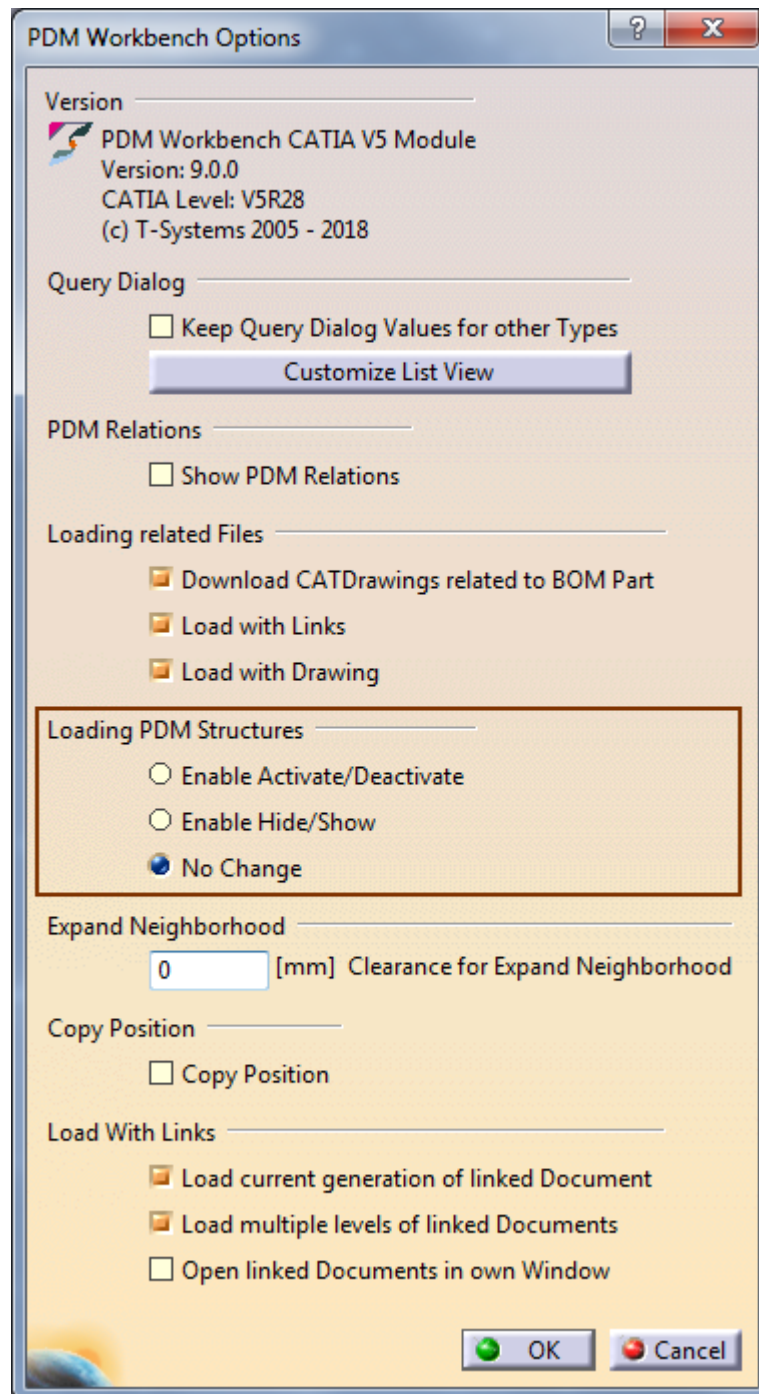

Picture 99: Additional options for “Loading PDM Structures”

Load Substructures in Context

BOM Part Structure Data Model

It is possible to load only selected nodes of a PDM structure to CATIA.

In the first step you expand a PDM structure in the PDM Structure window. Instead of loading the complete structure with “Load” you select any number of nodes in the tree and select the action “Load in Context” (see *Picture 100: Action “Load in Context” – with some structure nodes selected*).

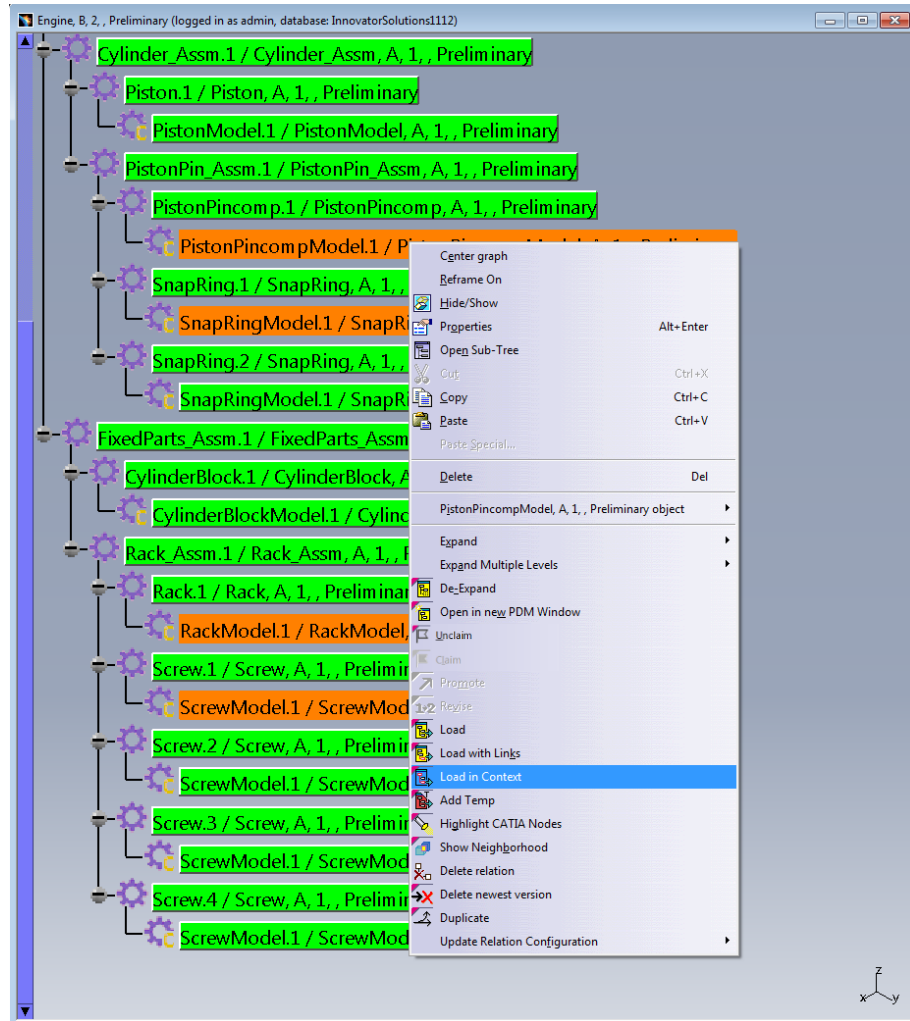

Picture 100: Action “Load in Context” – with some structure nodes selected

You have to confirm the action (see *Picture 101: Confirm the “Load in Context” action*).

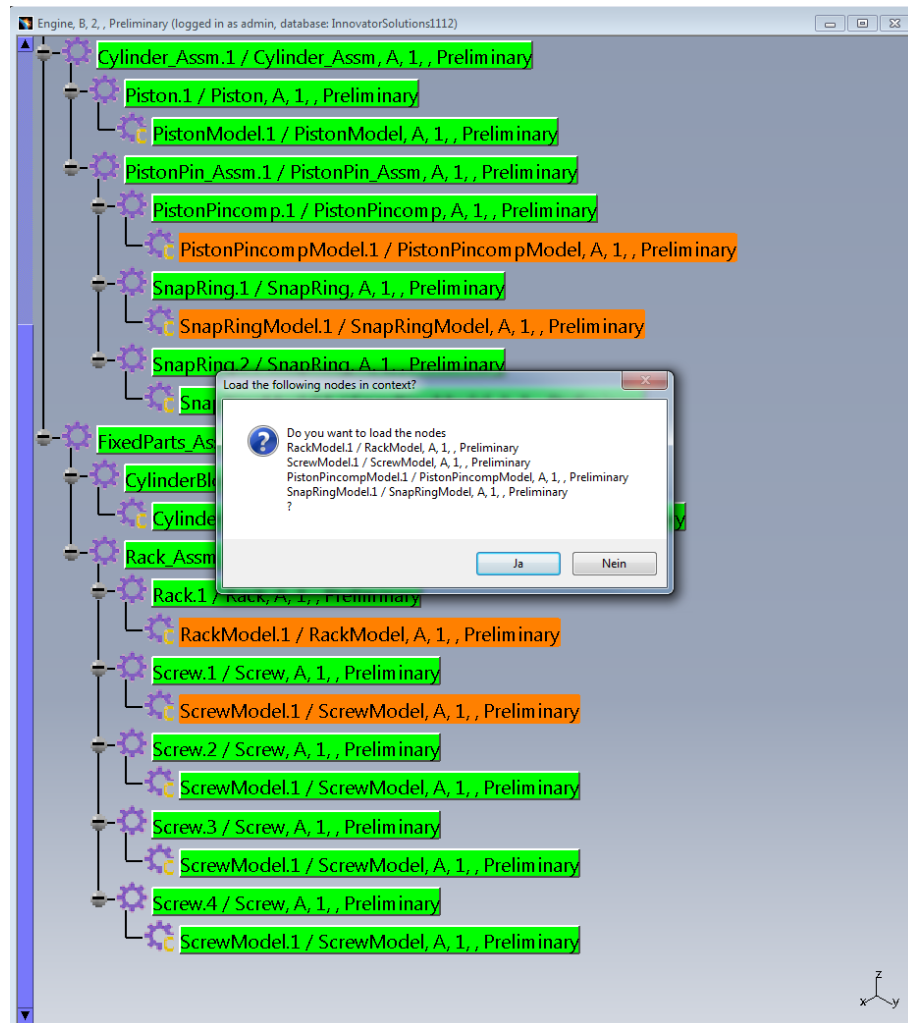

Picture 101: Confirm the “Load in Context” action

The selected objects are then loaded to CATIA (see *Picture 102: “Load in Context” – Selected objects loaded to CATIA*).

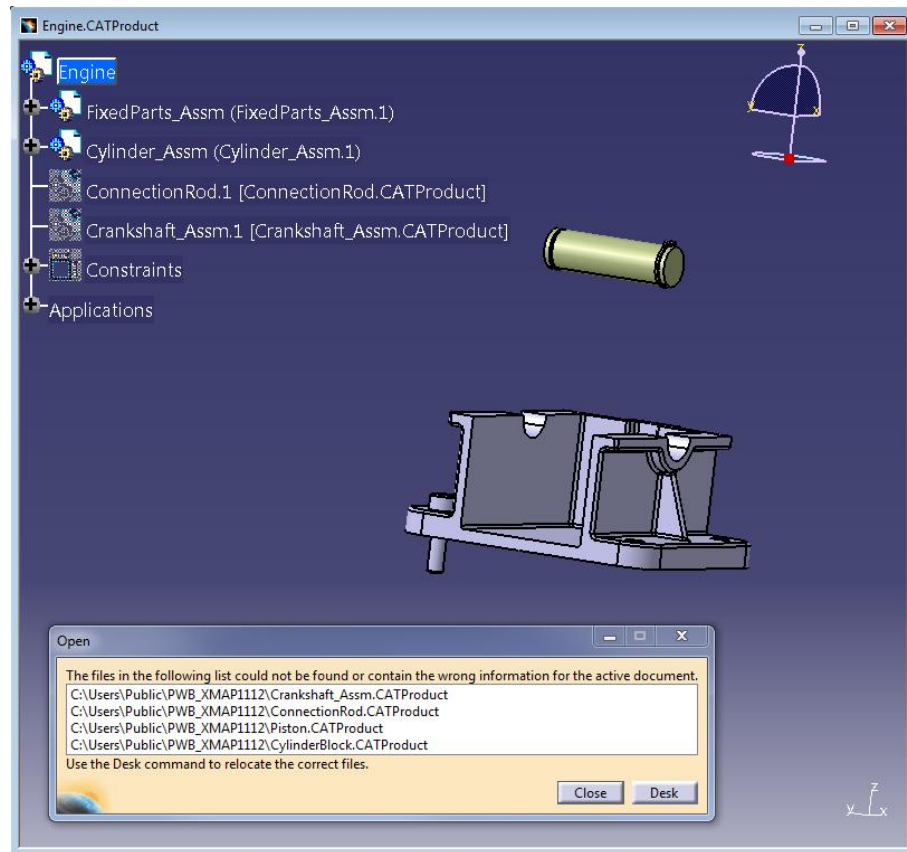

Picture 102: “Load in Context” – Selected objects loaded to CATIA

This amounts to the same as de-expanding all the unwanted parts of the structure and loading, but it is often faster and more convenient.

CAD Document Structure Data Model

It is possible to only load selected nodes of a PDM structure to CATIA.

In the first step you expand a PDM structure in the PDM Structure window. Instead of loading the complete structure with “Load” you select any number of nodes in the tree and select the action “Load in Context” (see *Picture 103: Action “Load in Context” – with some structure nodes selected*).

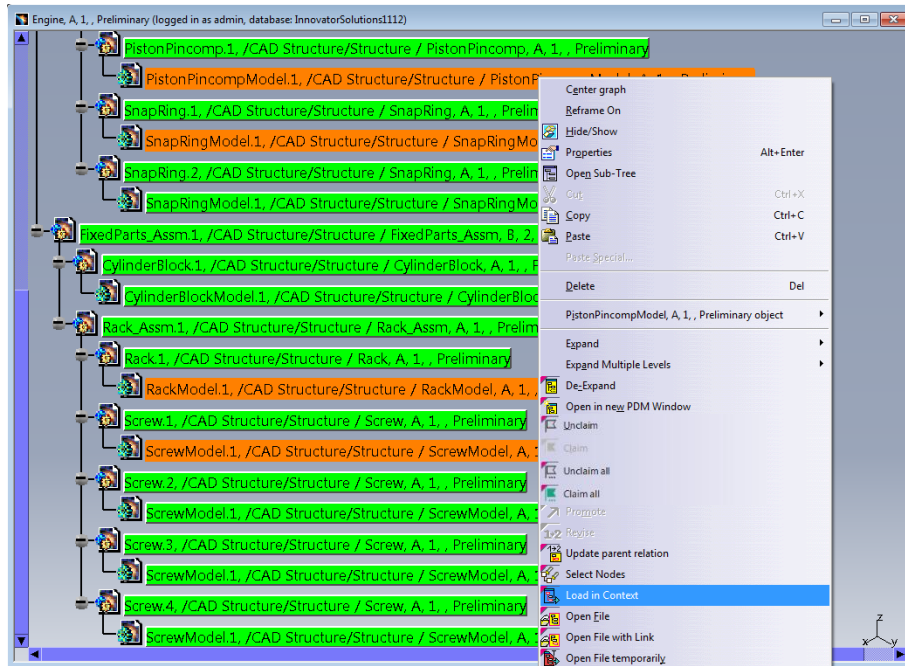

Picture 103: Action “Load in Context” – with some structure nodes selected

You have to confirm the action (see *Picture 104: Confirm the “Load in Context” action*).

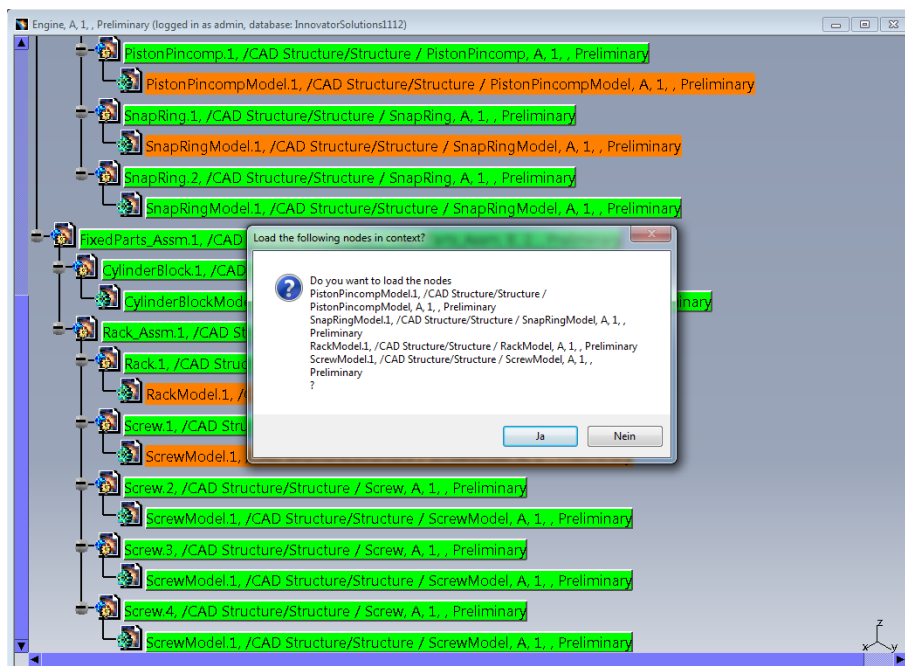

Picture 104: Confirm the “Load in Context” action

The complete PDM structure gets reduced to only the sub-set of the structure which contains the selected nodes (see *Picture 105: “Load in Context” – Reduced PDM structure in PDM Structure window*).

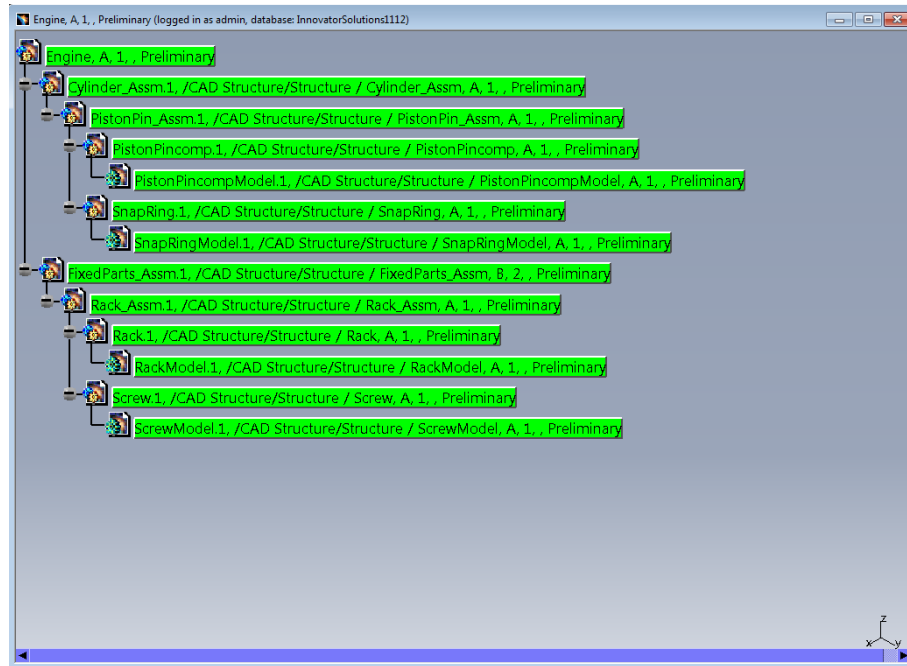

Picture 105: “Load in Context” – Reduced PDM structure in PDM Structure window

This reduced structure is then loaded to CATIA (see *Picture 106: “Load in Context” – Reduced structure loaded to CATIA*).

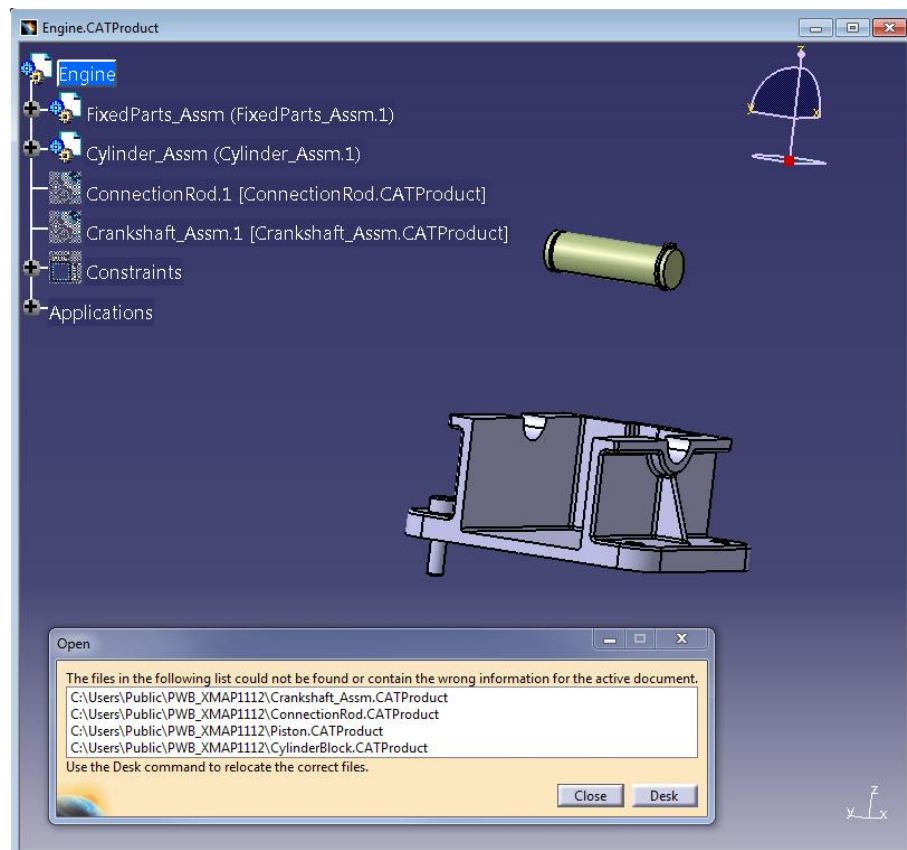

Picture 106: “Load in Context” – Reduced structure loaded to CATIA

This amounts to the same as de-expanding all the unwanted parts of the structure and loading, but it is often faster and more convenient.

Add Temp

The action "Add Temp" allows you to visualize a temporary structure together with the working one.

In the first step you load the current generation of the structure. In this example you open the revision "B" of the "Engine".

You select the object and click on the right mouse button. In the context menu you select the action "Load" (see *Picture 107: Action "Load"*).

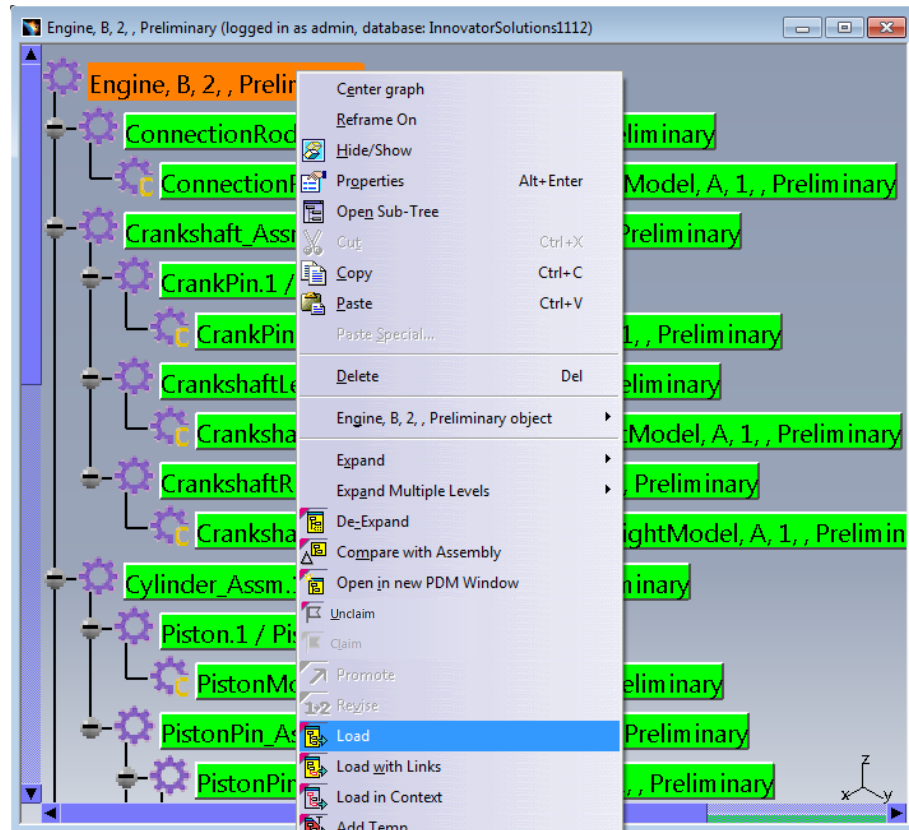

Picture 107: Action "Load"

The current generation of the structure is loaded in CATIA V5, now (see *Picture 108: Loaded geometry for revision "B"*).

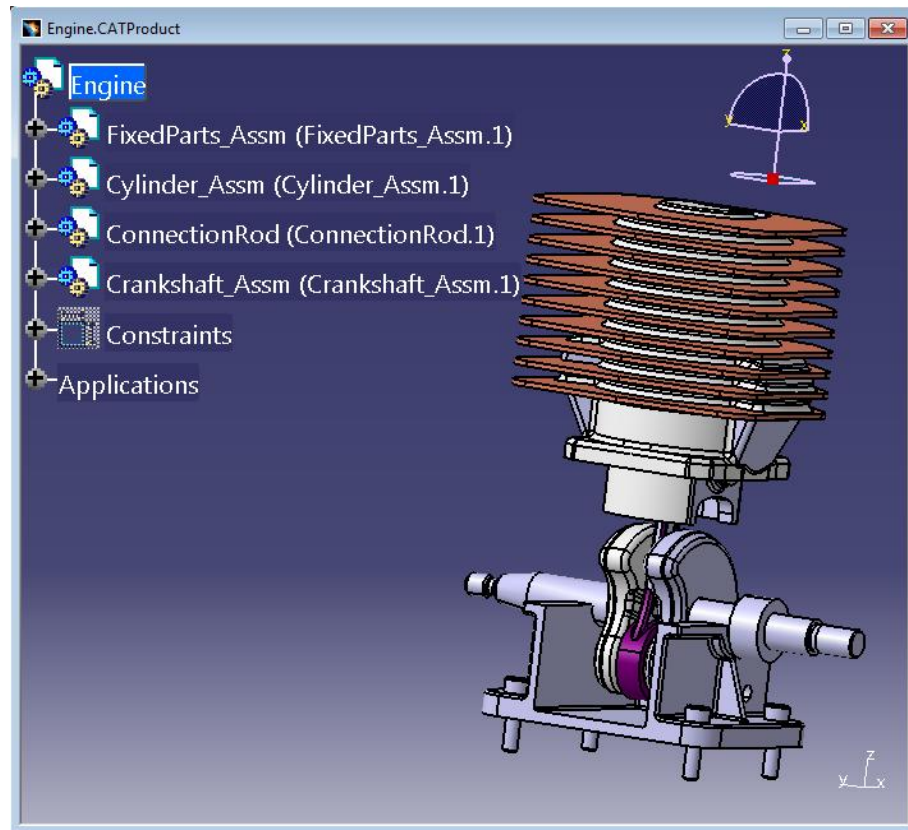

Picture 108: Loaded geometry for revision "B"

Then you query for a different generation (in this case revision "A") and load the structure temporary.

You select the object and click on the right mouse button. In the context menu you select the action "Add Temp" (see *Picture 109: Action "Add Temp"*).

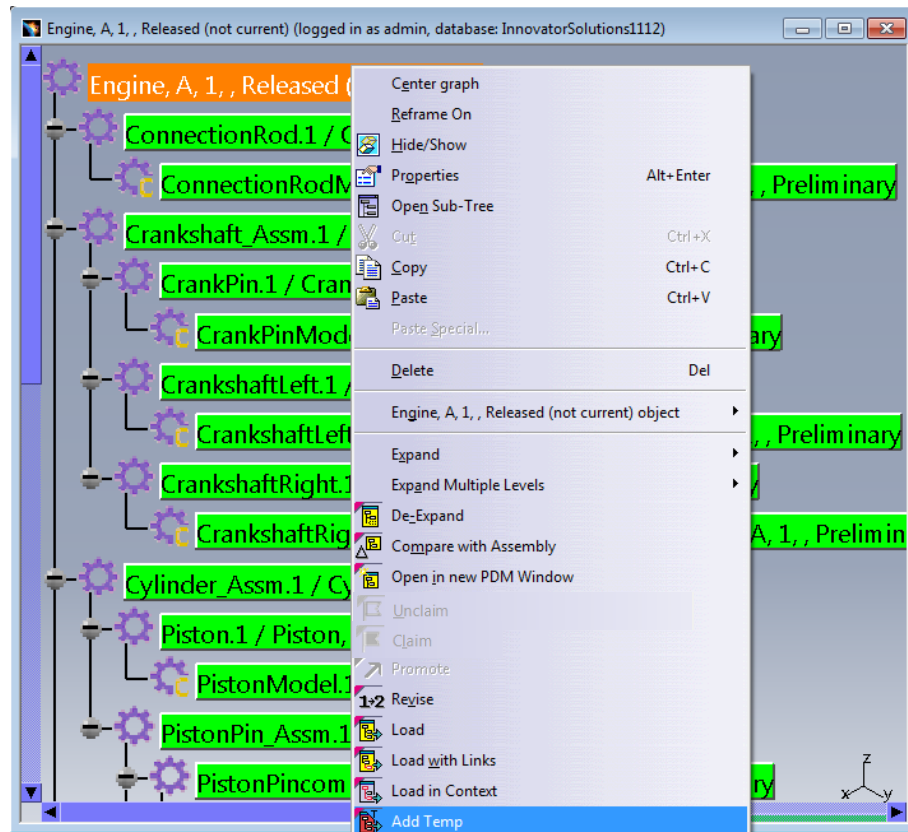

Picture 109: Action “Add Temp”

The CATProducts will not be loaded. Only the CATParts are loaded and positioned correctly (see *Picture 110: Loaded geometry for revision "A"*).

All Part Numbers and File Names in the temporarily added structure are prefixed with “TMP#_”, where “#” is a counter in CATIA V5, beginning with 1. Every action "Add Temp" will increase the counter. This prefix is customisable by the customer. For details please refer to the *PDM Workbench Installation & Administration Manual*.

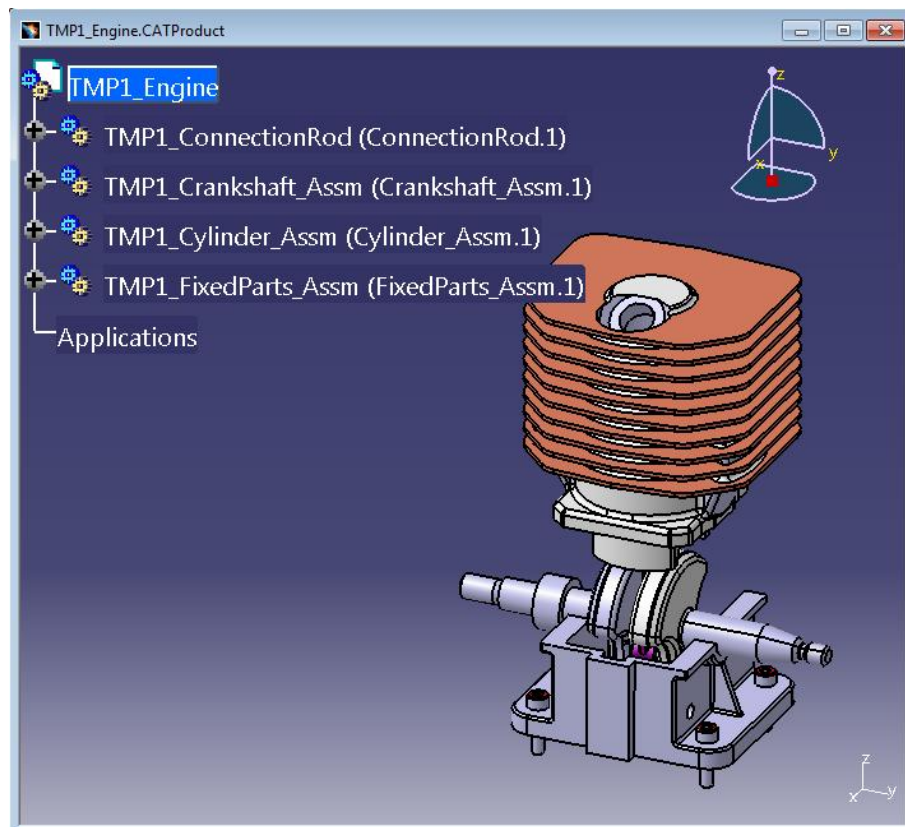

Picture 110: Loaded geometry for revision "A"

Now you can compare both geometry structures.

Duplicate

It is possible to duplicate existing CATProduct and CATPart objects.

You have to open the objects in CATIA V5 and click on the right mouse button in order to open the context menu. There you have to select the action "Duplicate" (see *Picture 111: Action "Duplicate"*).

For CATParts you have to use the "Duplicate" action in the "PDM Workbench context commands" toolbar.

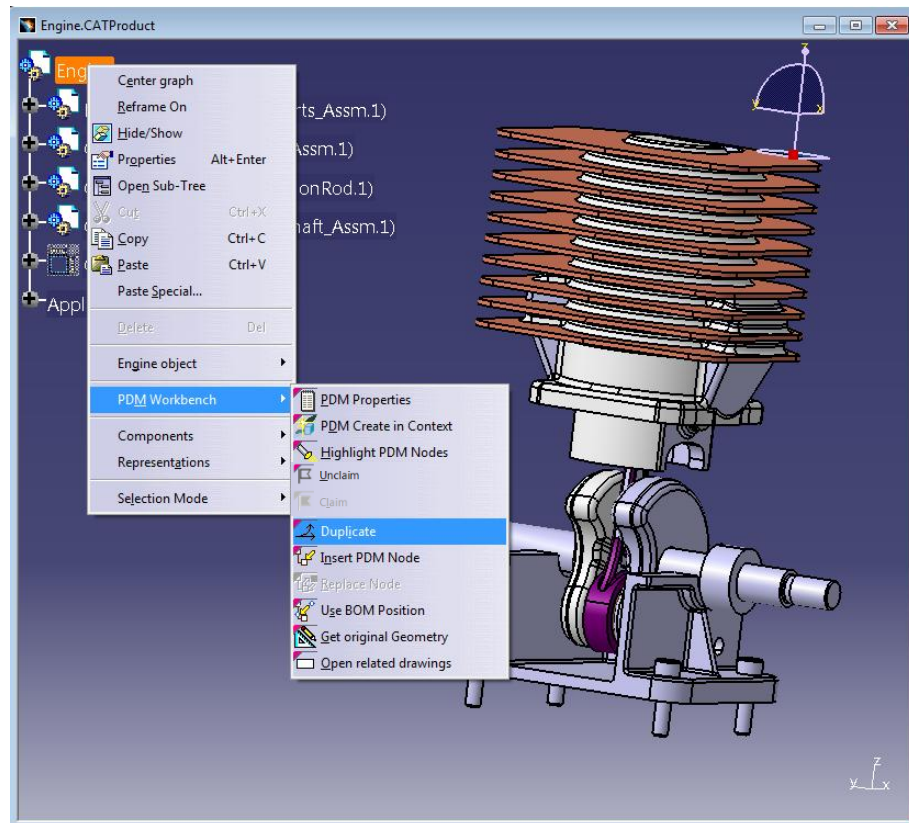

Picture 111: Action "Duplicate"

The "PDM Create" dialog will be opened. The correct type is already selected. The identifying name of the document is filled, too.

You have to fill or change the attributes (see *Picture 112: "PDM Create" dialog for duplicate*).

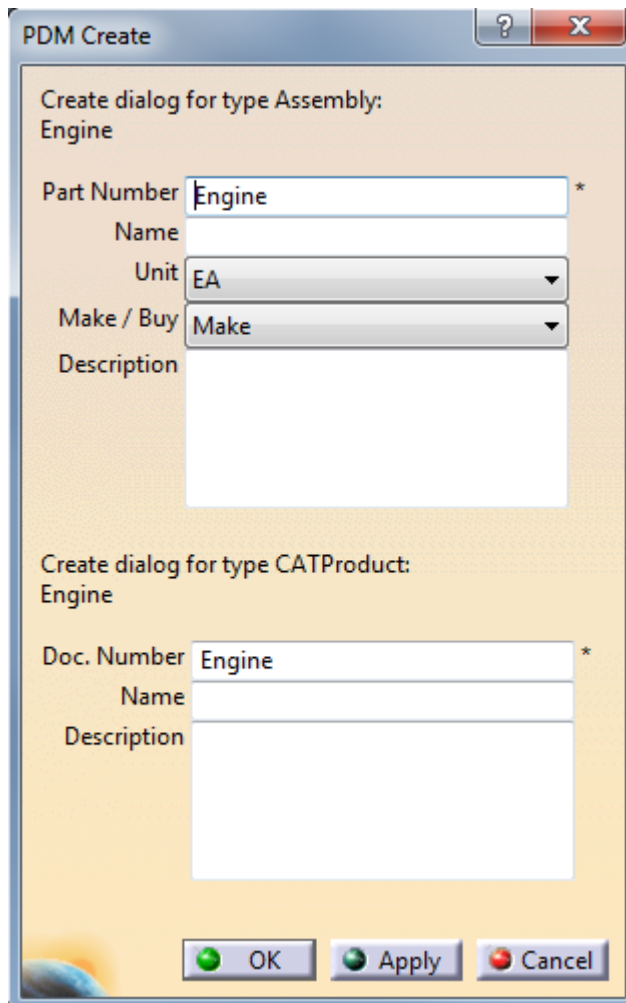

Picture 112: "PDM Create" dialog for duplicate

When you close the dialog with "OK" (see *Picture 113: Filled "PDM Create" dialog for duplicate*) the CATIA document will be renamed to the new Part Number and created in the PDM system (see *Picture 114: Duplicated CATProduct object*).

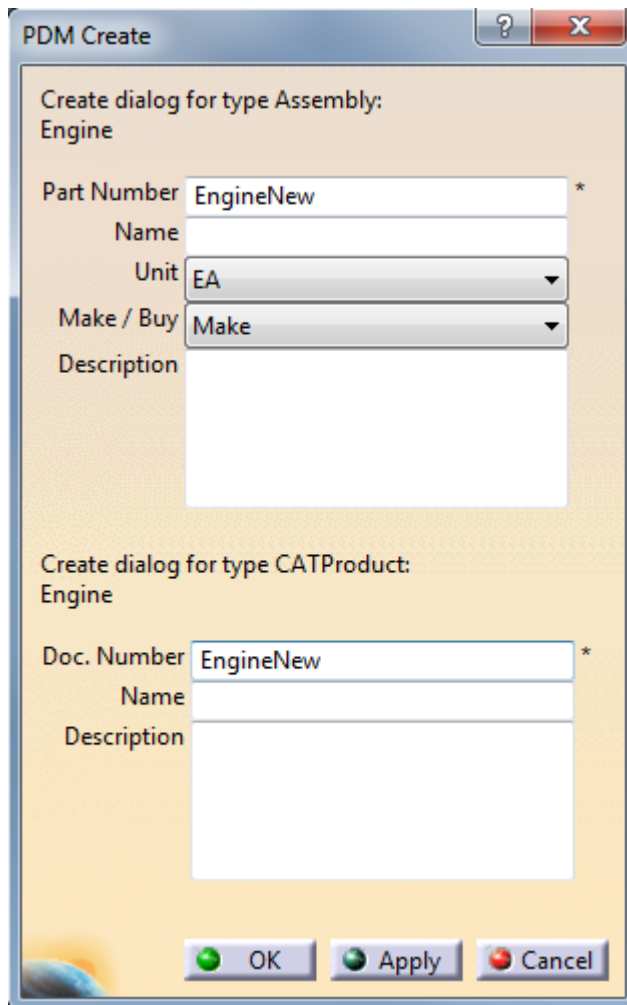

Picture 113: Filled "PDM Create" dialog for duplicate

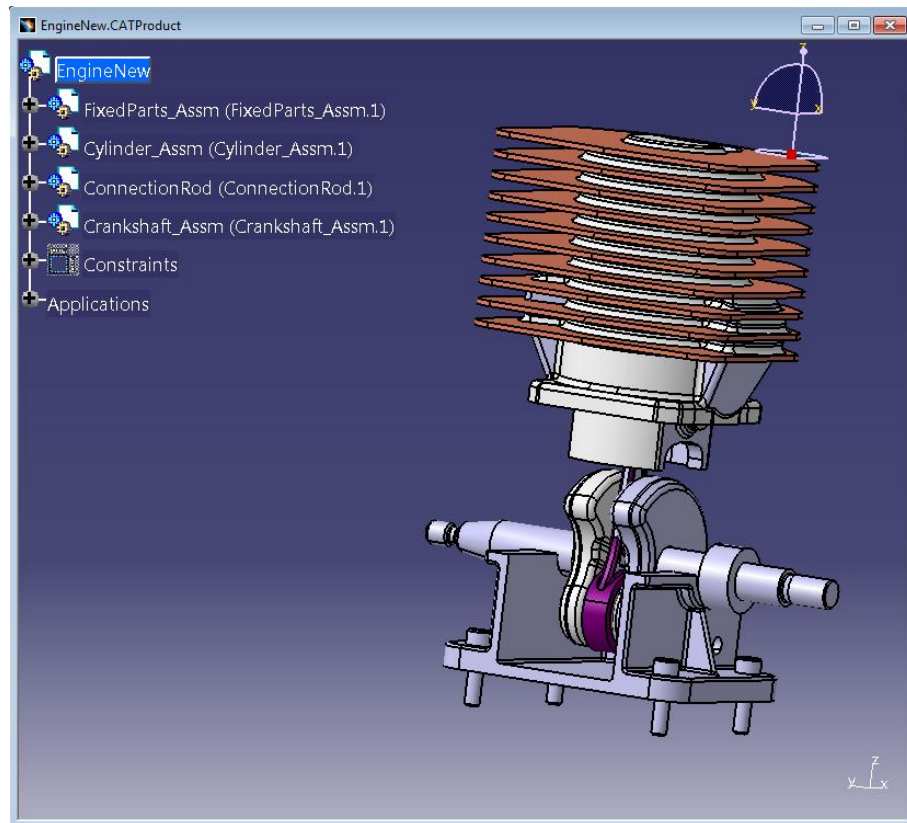

Picture 114: Duplicated CATProduct object

Improved “Parts in Session” Functionality in CAD Document Structure Data Model

The “Select a part in session” list previously was only populated in the BOM Part Structure Data Model, by part items that have been loaded into the CATIA session. Now, in the “Duplicate” process in the CAD Document Structure Data Model, it contains a list of Part items that are related to the CAD Documents that are duplicated.

During the “Duplication” process, in this example of a CATDrawing and two linked CATParts, it is not necessary to use the “Query for part” entry to get access to the Part items which are linked to the CAD Documents to be duplicated, since they can be selected in the list under “Select a part in session”:

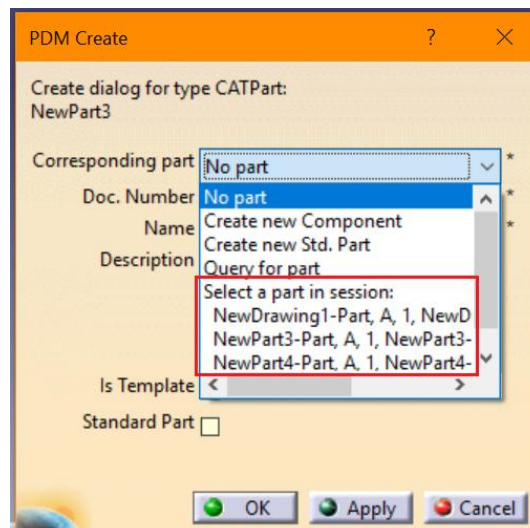

Picture 115: Dropdown list containing related parts

Even if a new part item is created during the process, it is accessible later in the “Duplication” process:

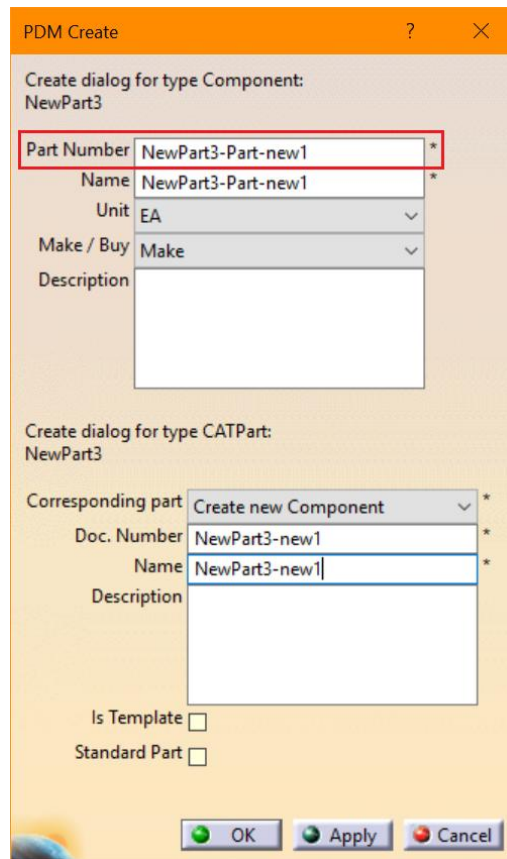

Picture 116: Dialog where a new part is created

If the “Duplicate” process continues this newly created part item is also available in the dropdown list:

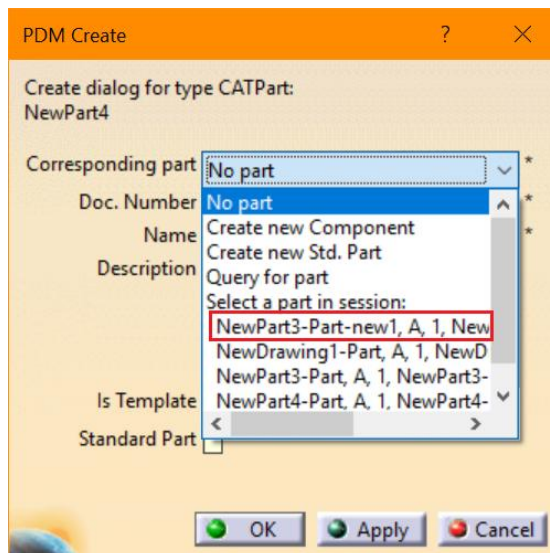

Picture 117: Dropdown list containing newly created Part

Selecting this part from the list has the same effect as querying for it and selecting it from the query results:

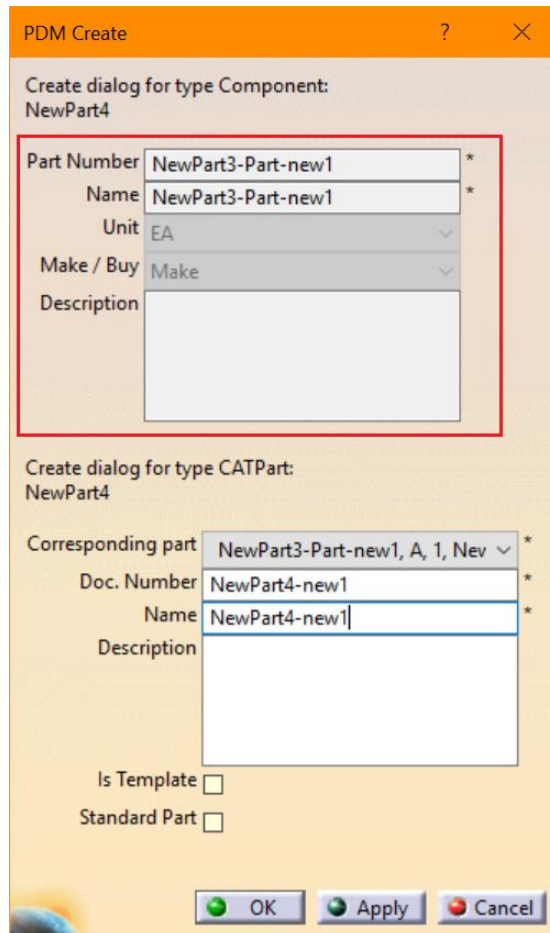

Picture 118: Dialog with newly created Part selected

With this functionality it is simpler to relate all the duplicated CAD Documents to the same Part item:

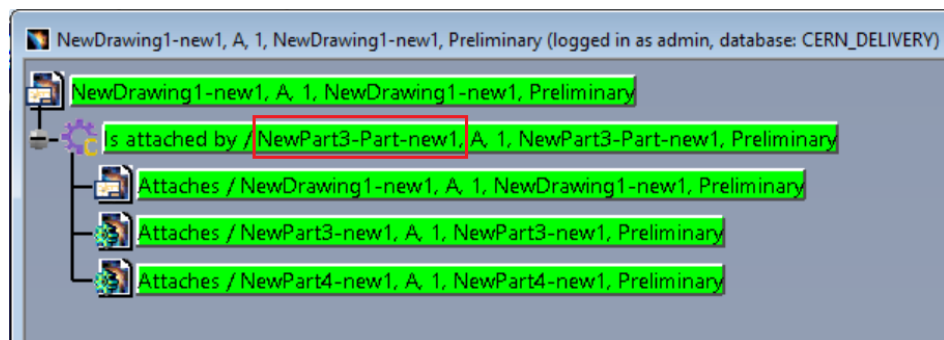

Picture 119: Dialog with newly created Part selected

Duplicate Structure

It is possible to duplicate CATProduct structures, not only single CATPart or CATProduct documents.

The Part Numbers of duplicated CATParts or CATProducts must not be controlled by internal CATIA business logic like knowledge ware.

In the PDM Workbench Schema file one of the following two variants can be configured. It is not possible to use both variants in the same PDM Workbench environment.

Variant A (only available in CAD Document Structure Data Model)

Use Case:

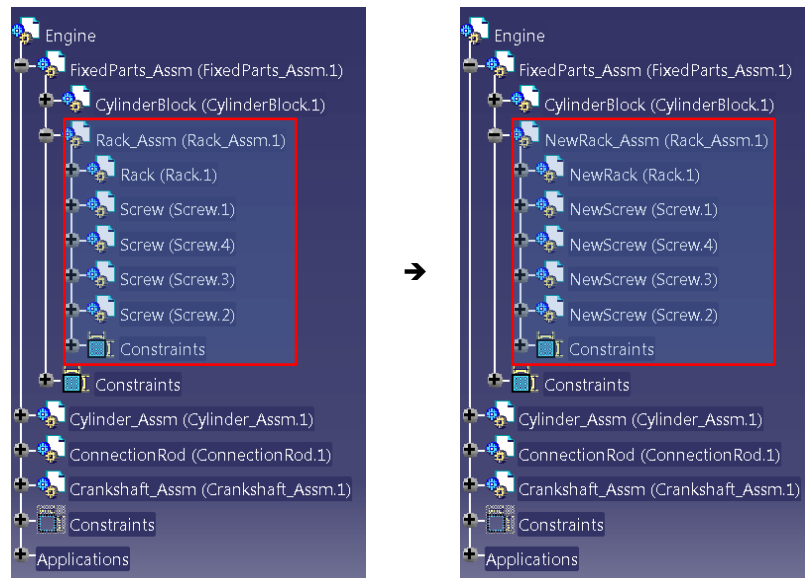

- Update in PDM required
- New sub-structure will be related to existing structure

Select a CATProduct and click the context action “Duplicate Structure” (see *Picture 120: Structure to be duplicated*).

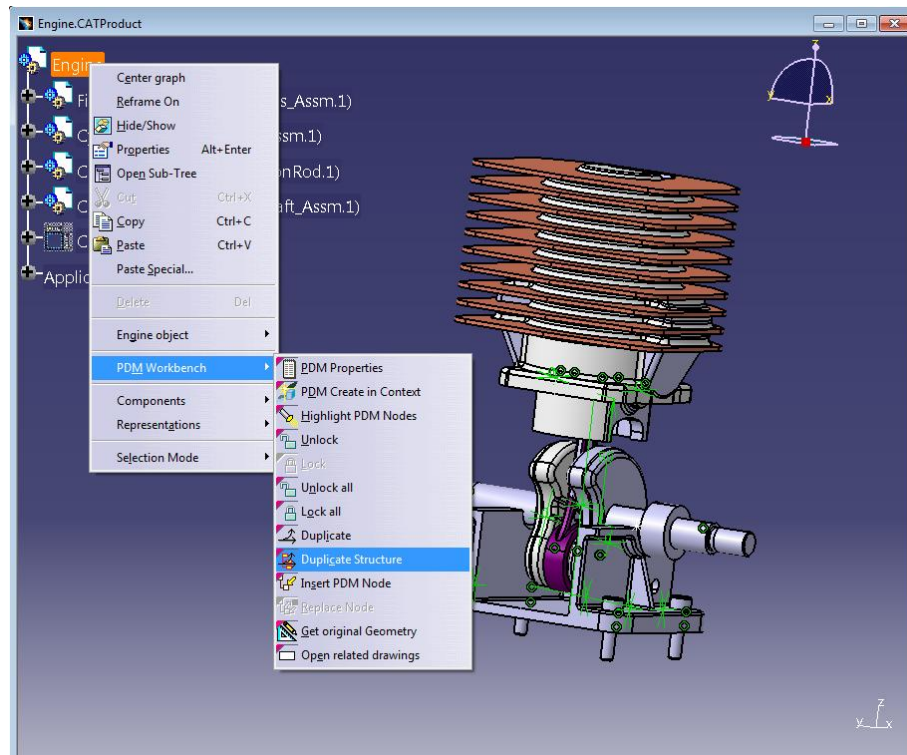

Picture 120: Structure to be duplicated

After clicking on “Duplicate Structure” you will get a list of the CATProducts and CATParts which are contained in the selected structure (see *Picture 121: Pre-selected list of documents*). Initially all CATIA documents are checked.

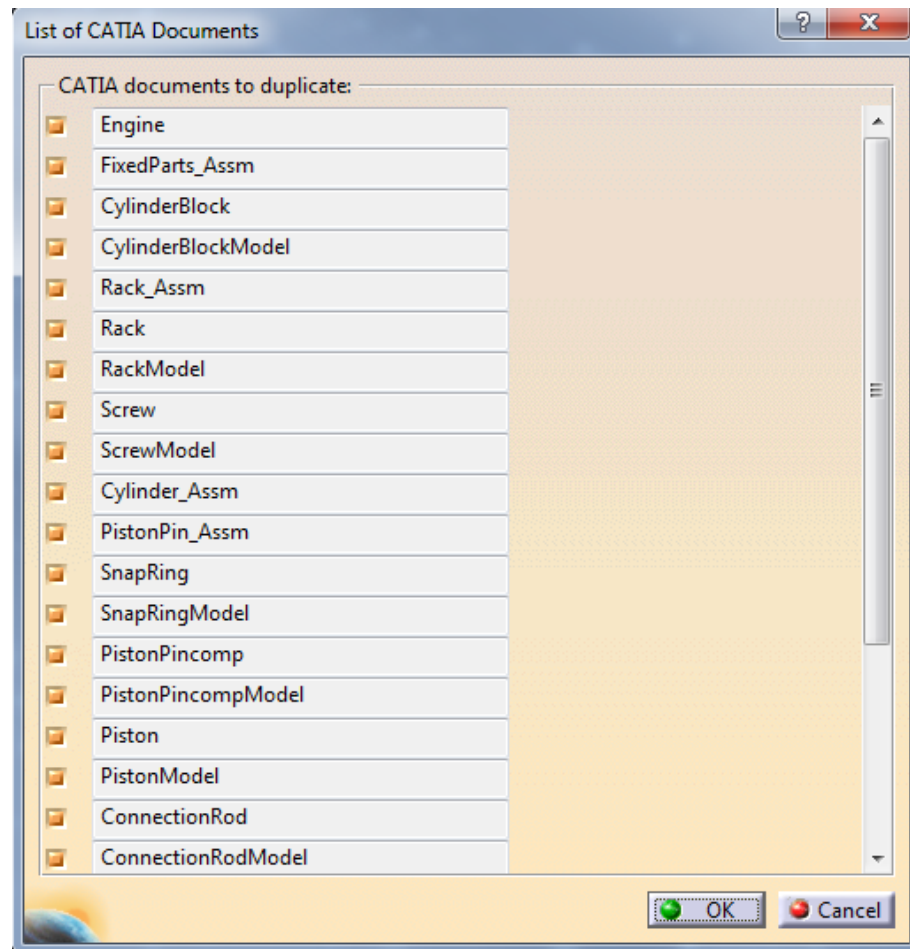

Picture 121: Pre-selected list of documents

You can uncheck any of the documents in the list (see *Picture 122: Document list with unchecked documents*). Only the checked documents will be duplicated.

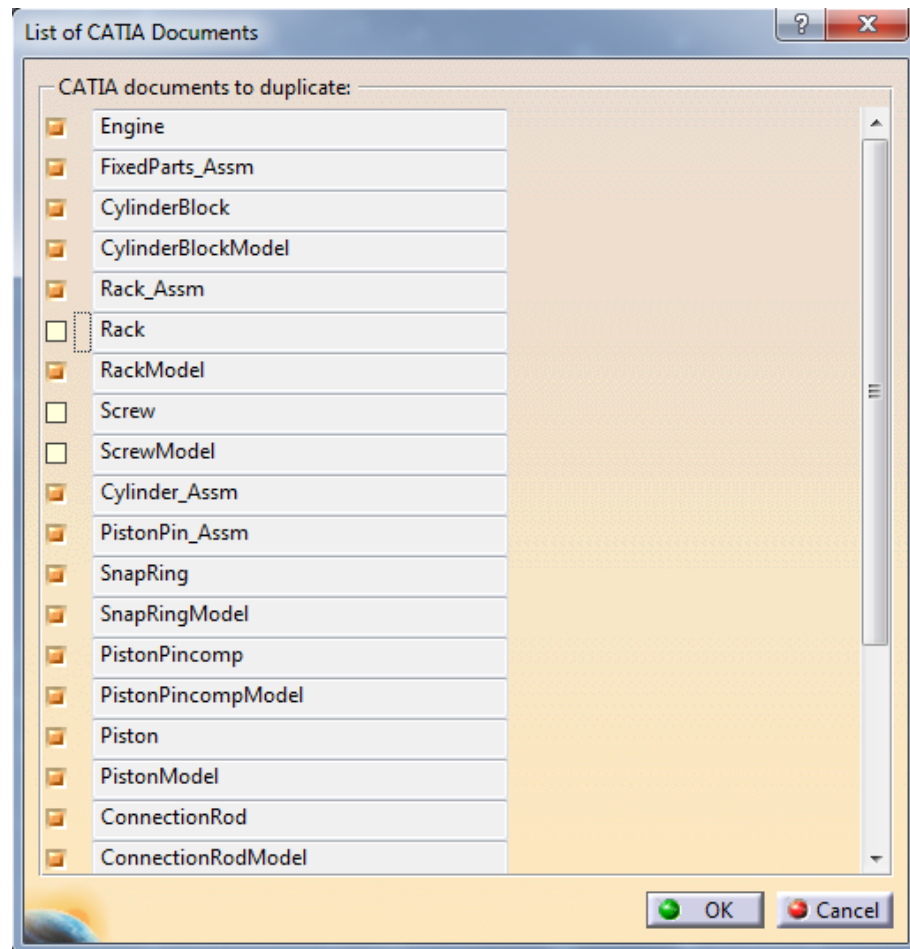

Picture 122: Document list with unchecked documents

In this example the "Rack_Assm" substructure of the "Engine" structure will be duplicated. You right-click on "Rack_Assm" → "PDM Workbench" → "Duplicate Structure" (see *Picture 123: Selecting a substructure to duplicate*).

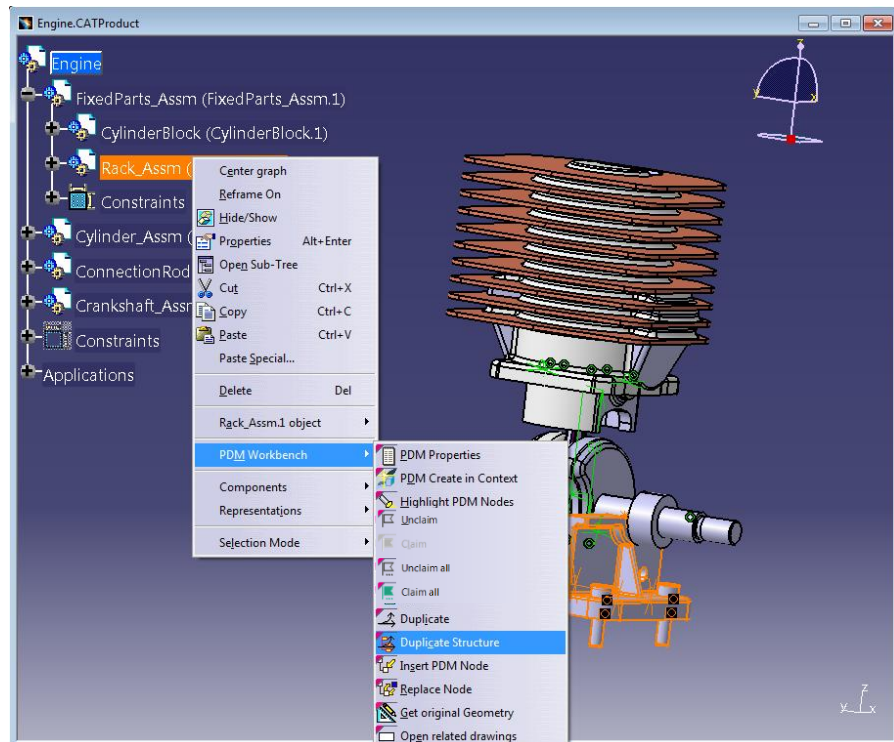

Picture 123: Selecting a substructure to duplicate

The list of the CATIA documents which are contained in the selected substructure appears (see *Picture 124: Example with small substructure*).

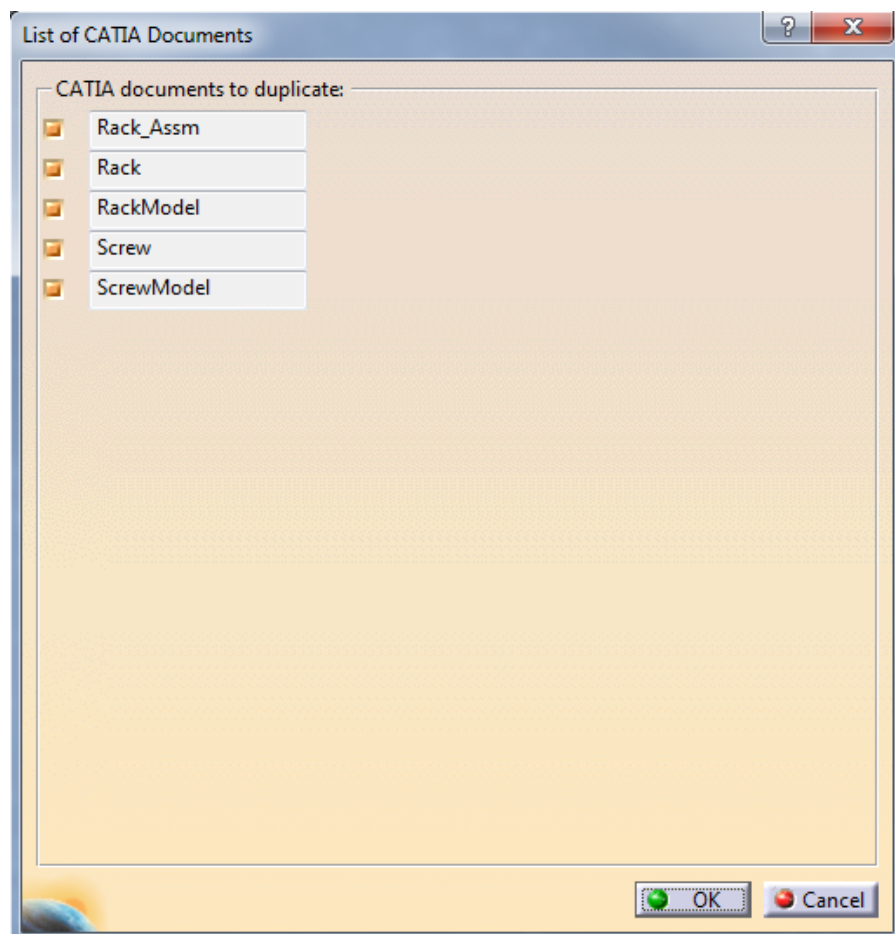

Picture 124: Example with small substructure

If you click on “OK” the “PDM Create” dialogs for each checked CATIA document will appear (see *Picture 125: Changed key attribute*). As in the single-document “Duplicate” functionality they will contain the values of the document to be duplicated. You need to change the key attribute.

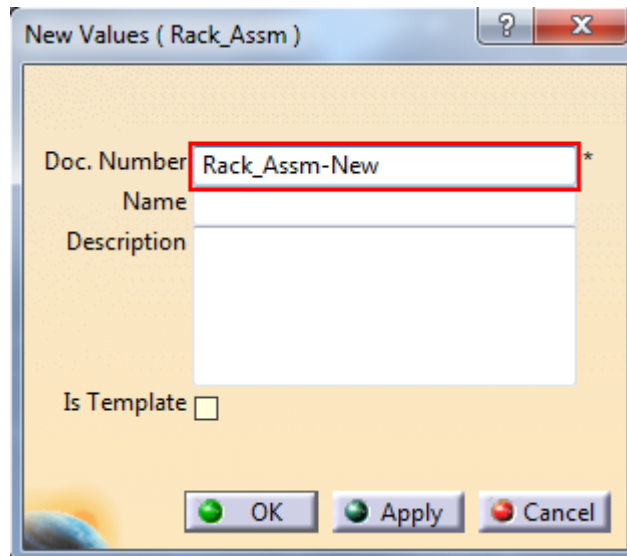

Picture 125: Changed key attribute

This is the structure that is being duplicated (see *Picture 126: Structure being duplicated*).

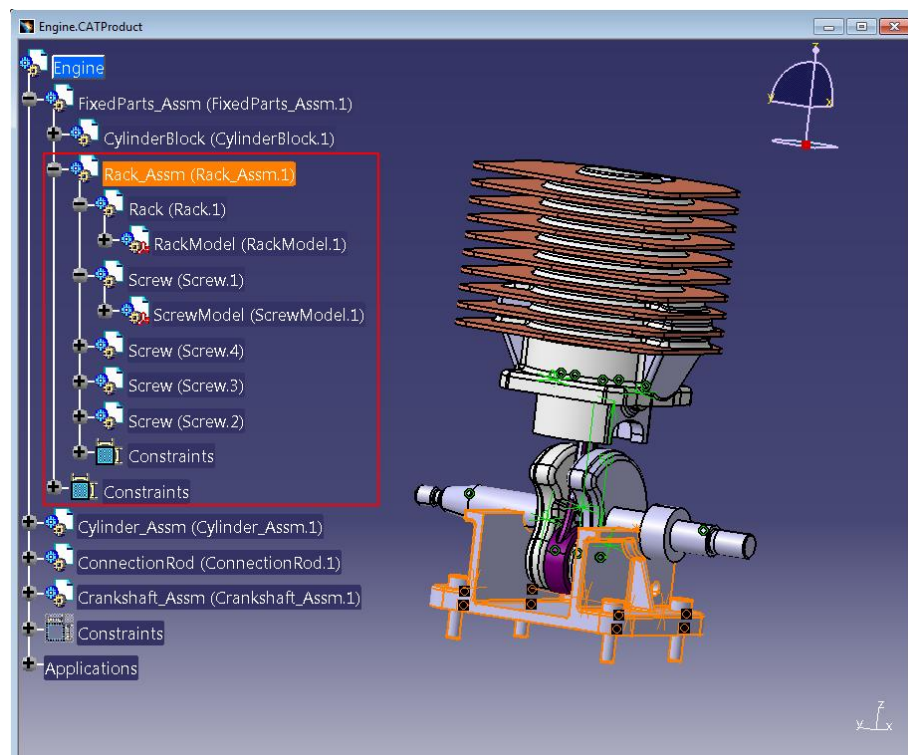

Picture 126: Structure being duplicated

When all dialogs have been filled out the “Duplicate” process starts (see *Picture 127: Duplicate Structure – progress bar*).

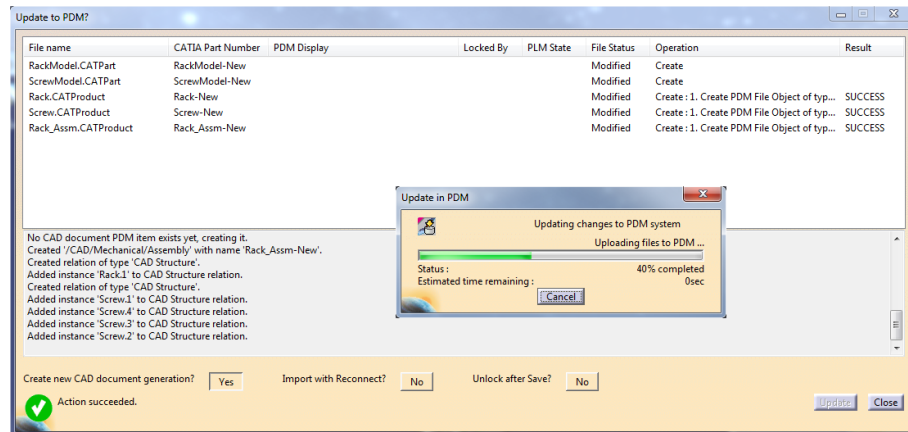

Picture 127: Duplicate Structure – progress bar

If a substructure has been duplicated the existing complete PDM structure is not changed yet, it still contains the old substructure ... (see *Picture 128: Existing PDM structure containing old substructure*)



Picture 128: Existing PDM structure containing old substructure

... even though the CATIA structure already contains the new substructure (see *Picture 129: CATIA structure containing new substructure*).

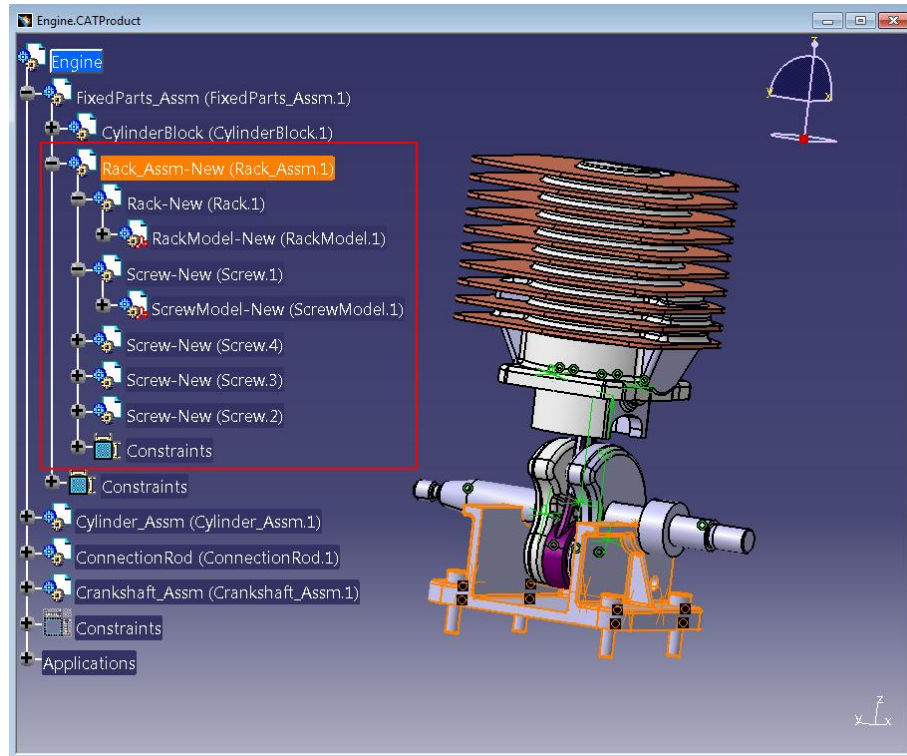

Picture 129: CATIA structure containing new substructure

For actually linking the newly duplicated substructure to the existing structure a PDM update has to be performed. This is the same behavior as the single-document “Duplicate” functionality has.

Performing the PDM Update (see *Picture 130: Update with new substructure*).

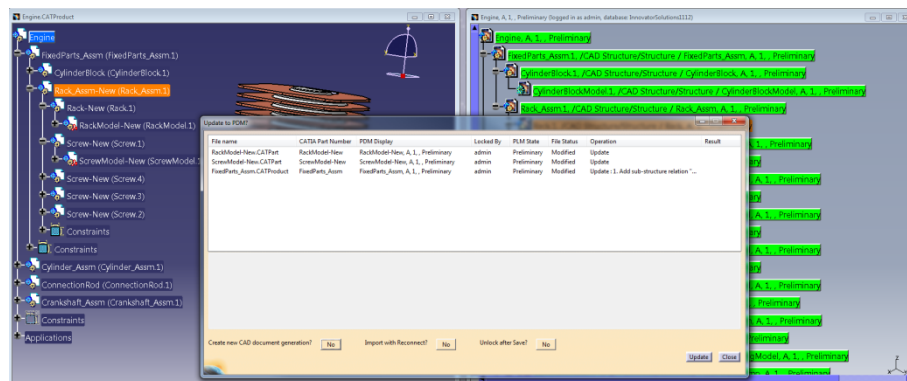

Picture 130: Update with new substructure

The result of the update is described in the text area of the window (see *Picture 131: Update has changed the structure to the new substructure*).

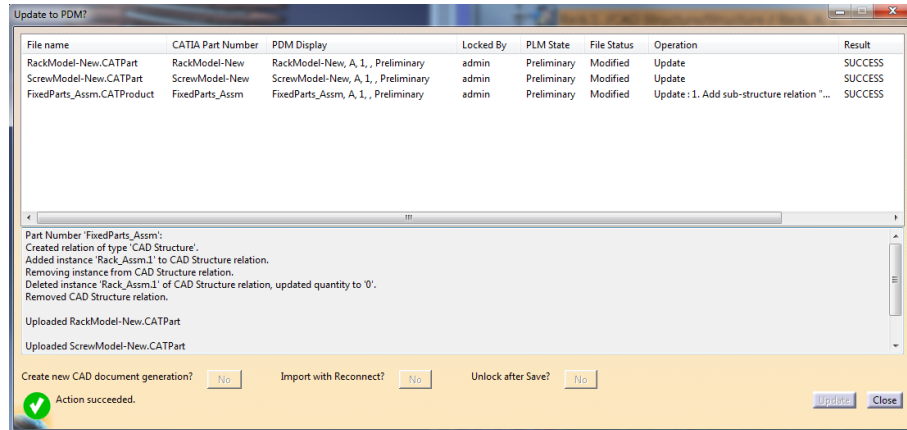

Picture 131: Update has changed the structure to the new substructure

After the update the complete PDM structure contains the new substructure (see *Picture 132: Existing PDM structure containing new substructure*).



Picture 132: Existing PDM structure containing new substructure

Variant B

Use Case:

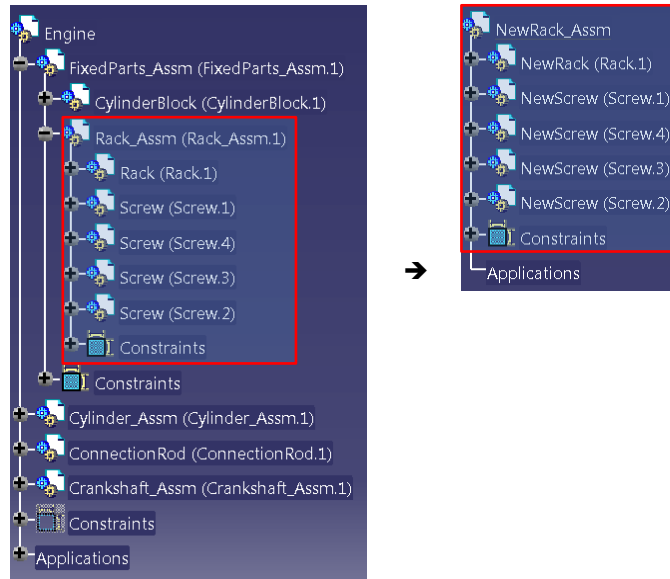

- Update in PDM required
- New sub-structure will not be related to existing structure

When using “Duplicate Structure” it is possible to add the original Item to a property in the new Item (CAD/Part).

You can select any node in a loaded CATProduct structure, including the root node. If the root node is selected then the whole structure will be duplicated, otherwise a part of the complete structure.

Select a CATProduct and click the context action “Duplicate Structure” (see *Picture 133: Structure to be duplicated*).

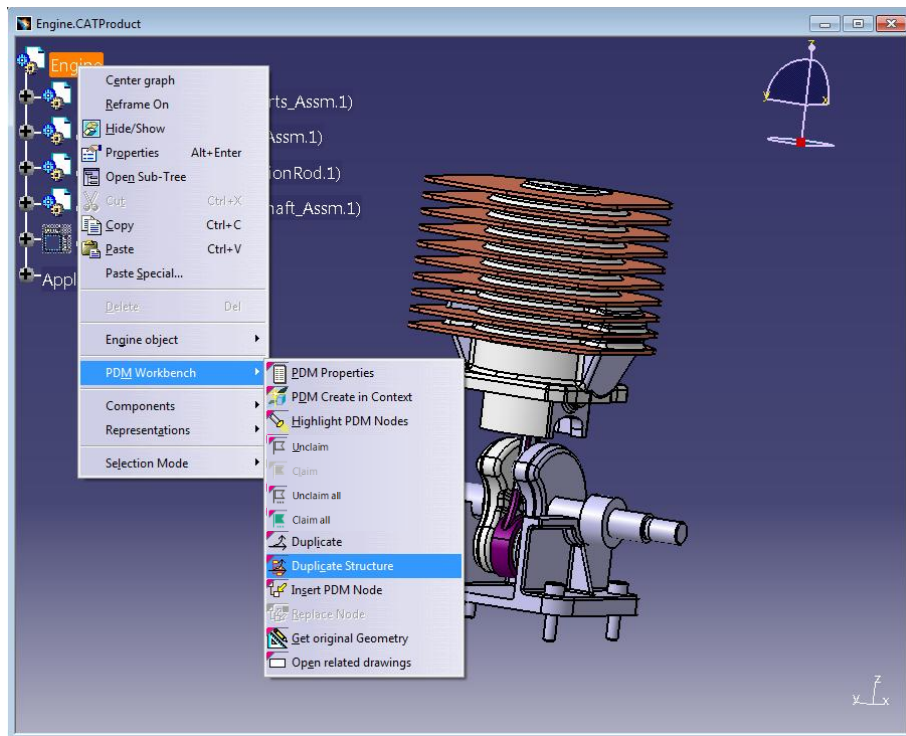

Picture 133: Structure to be duplicated

After clicking on “Duplicate Structure” you will get a list of the CATProducts and CATParts which are contained in the selected structure (see *Picture 134: Duplicate structure – Pre-selected list of documents*). Initially all CATIA documents are checked.

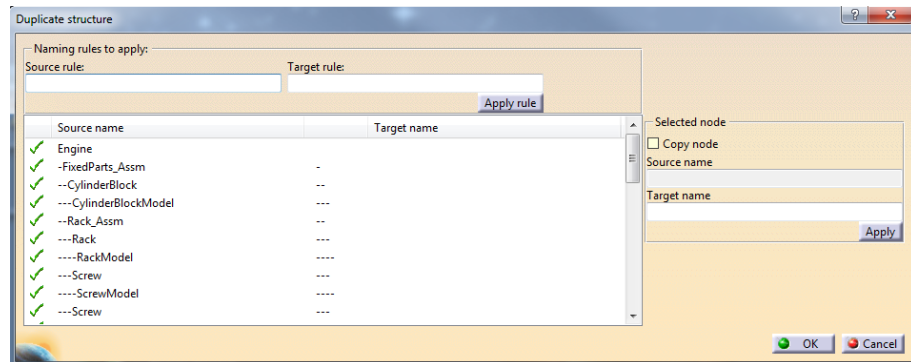

Picture 134: Duplicate structure – Pre-selected list of documents

You can uncheck any of the documents in the list. Only the checked documents will be duplicated.

You have to select the sub-tree or object to be unchecked in the list of the left side. On the right side of the dialog the information about the selected node will be updated, e.g. check-box “Copy node” and field “Source name” will be filled. (see *Picture 135: Duplicate structure – Selected node*).

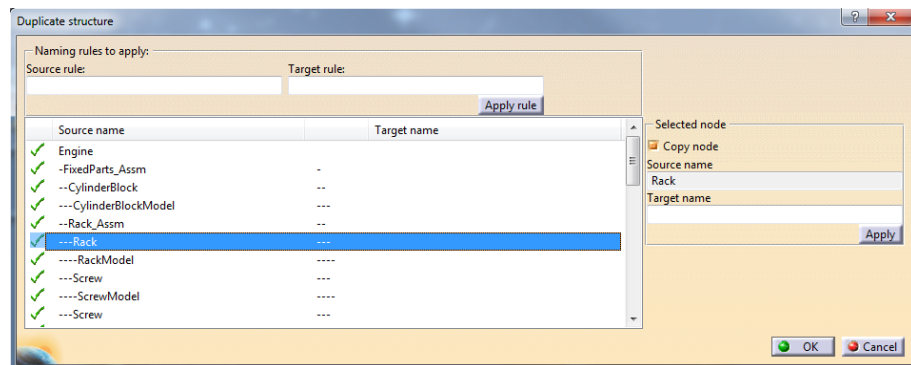

Picture 135: Duplicate structure – Selected node

You have to uncheck the check-box “Copy node” (see *Picture 136: Duplicate structure – Uncheck selected node*).

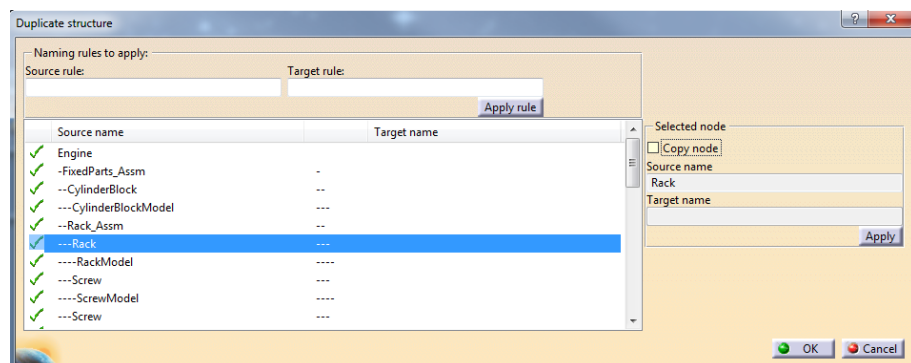

Picture 136: Duplicate structure – Uncheck selected node

In the next step please click the “Apply” button. The sub-tree or object will be unchecked in the list of the left side (*Picture 137: Duplicate structure – Document list with unchecked documents*).

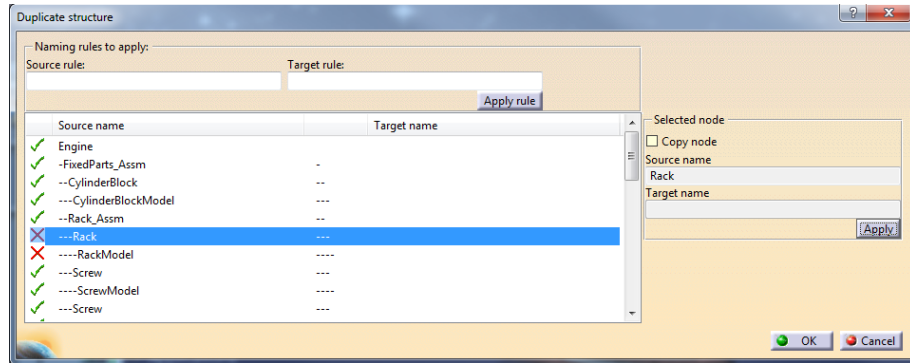

Picture 137: Duplicate structure – Document list with unchecked documents

You can define a naming rule for all nodes to be duplicated by filling the “Source rule” and “Target rule” using wildcard “*” (see *Picture 138: Duplicate structure – Fill naming rule*).

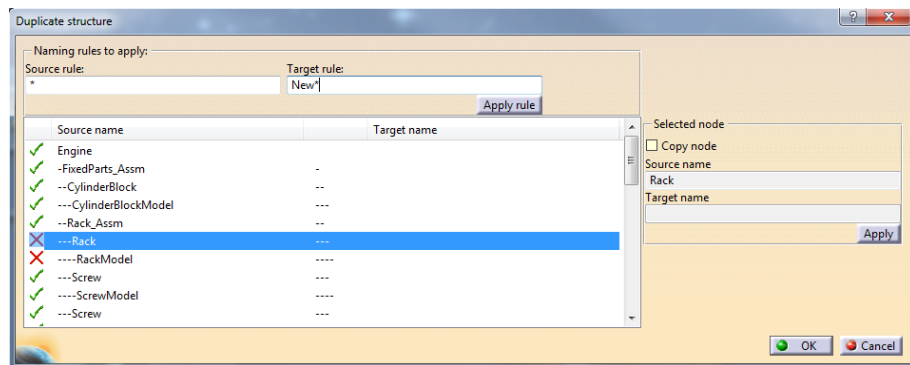

Picture 138: Duplicate structure – Fill naming rule

When you click the “Apply rule” button the Target name will be filled for the objects to be duplicated (see *Picture 139: Duplicate structure – New Target names*).

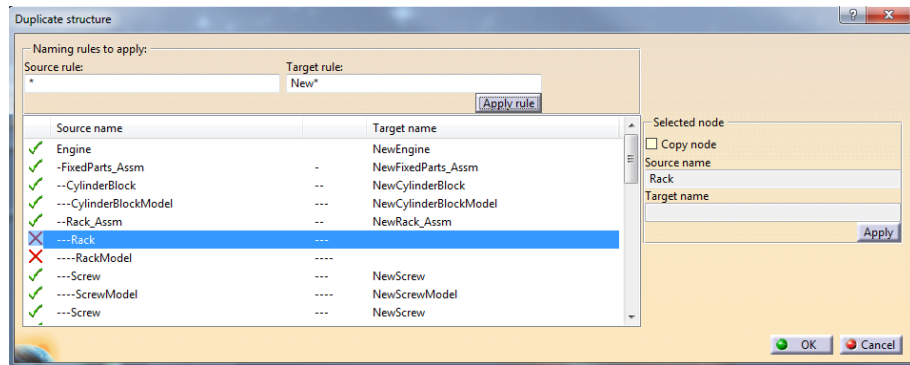

Picture 139: Duplicate structure – New Target names

Alternatively, you can define the Target name on the right side of the dialog by selecting the different nodes of the list of the left (see *Picture 140: Duplicate structure – Fill single Target name*).

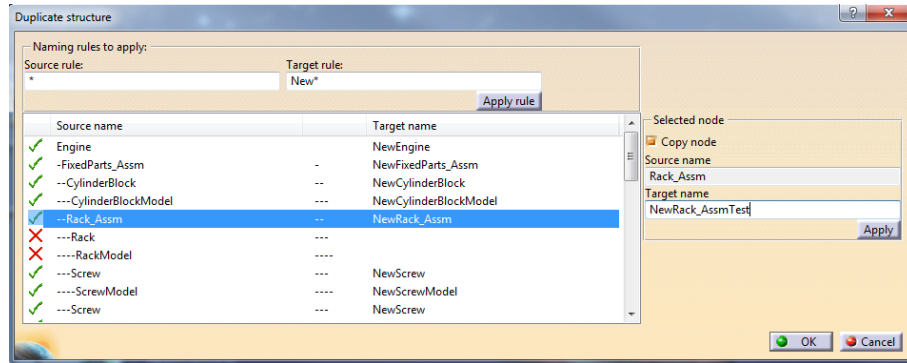

Picture 140: Duplicate structure – Fill single Target name

Click the “Apply” button to set the Target name (see *Picture 141: Duplicate structure – Filled single Target name*).

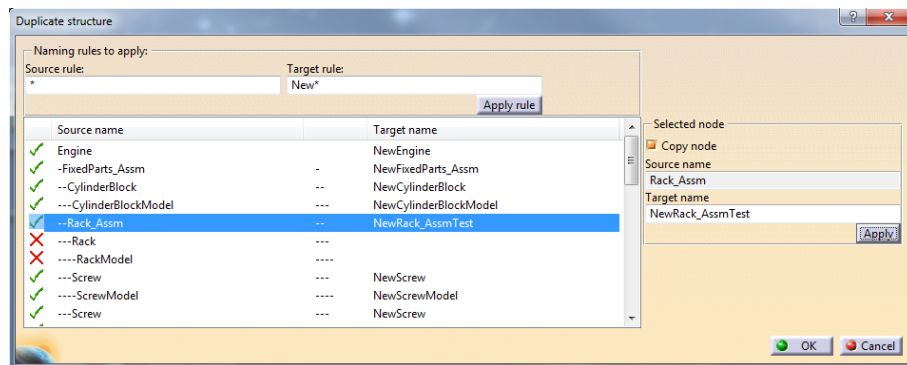

Picture 141: Duplicate structure – Filled single Target name

When you click on “OK” the structure will be duplicated (see *Picture 142: Duplicated structure in CATIA*).

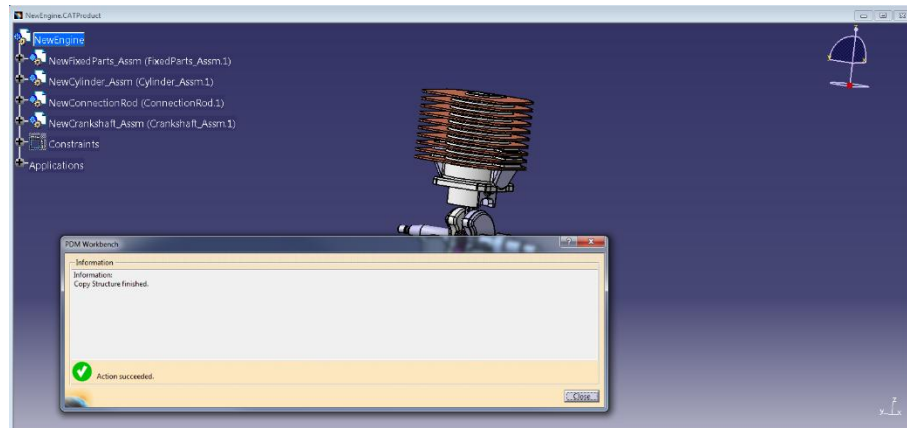

Picture 142: Duplicated structure in CATIA

The new structure has to be synchronized in Aras Innovator (see *Picture 143: Synchronize the duplicated structure*).

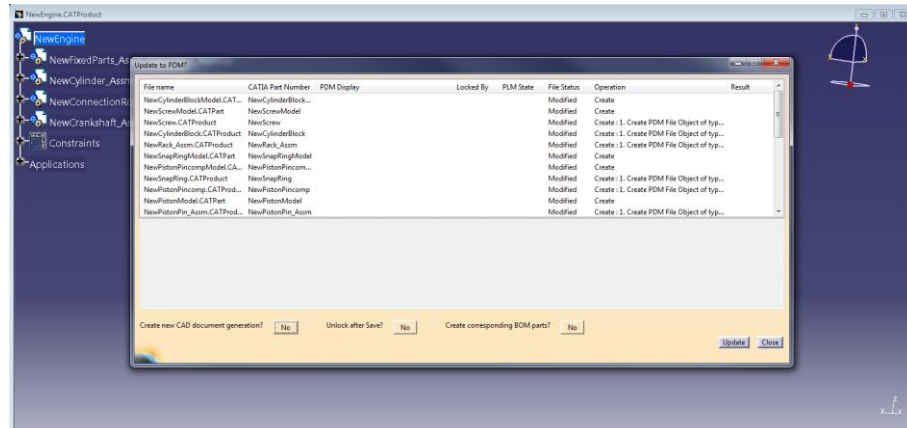

Picture 143: Synchronize the duplicated structure

In this example the “Rack_Assm” substructure of the “Engine” structure will be duplicated. You right-click on “Rack_Assm” → “PDM Workbench” → “Duplicate Structure” (see *Picture 144: Selecting a substructure to duplicate*).

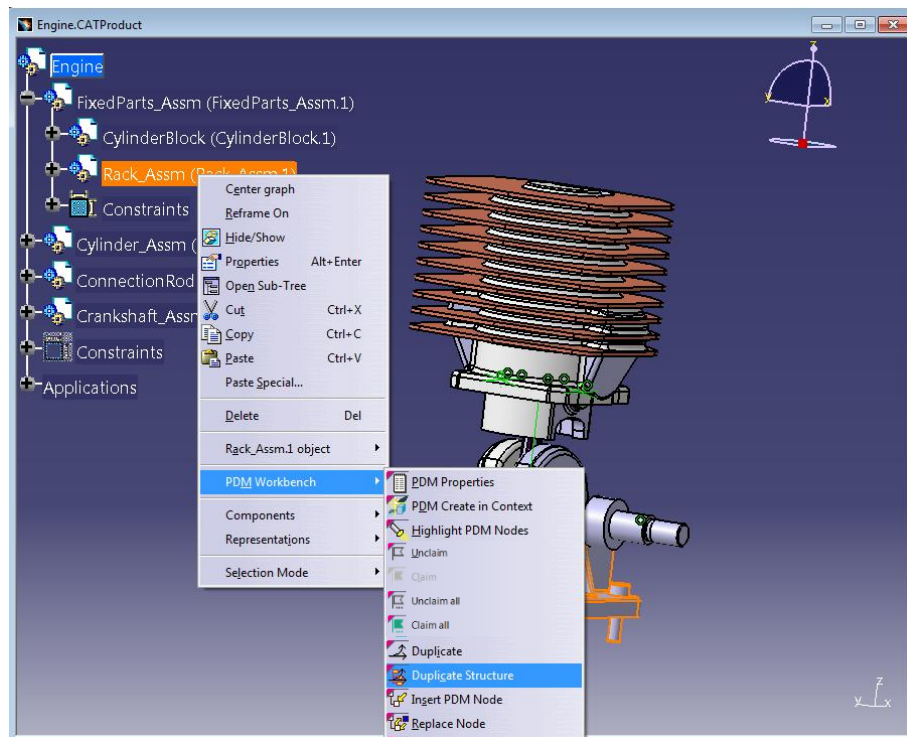

Picture 144: Selecting a substructure to duplicate

The list of the CATIA documents which are contained in the selected substructure appears (see *Picture 145: Example with small substructure*).

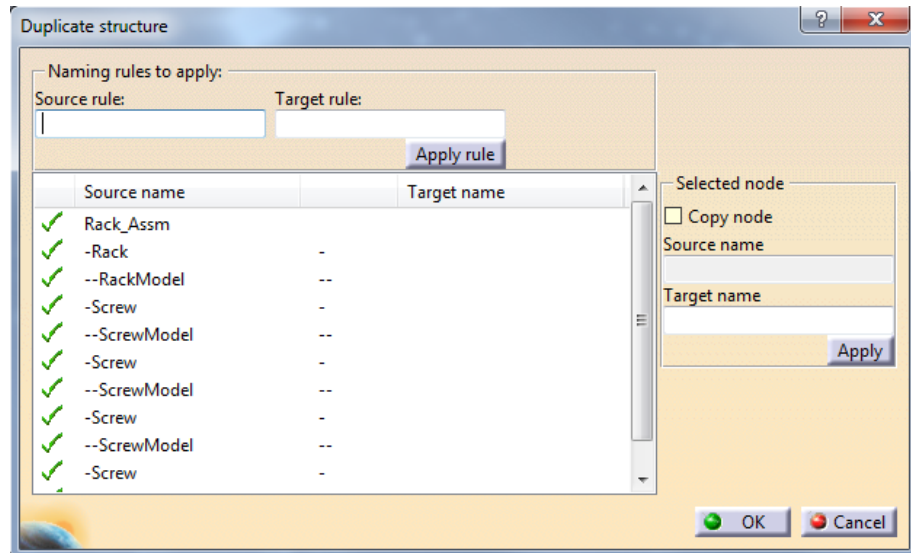

Picture 145: Example with small substructure

You can define a naming rule for all nodes to be duplicated by filling the “Source rule” and “Target rule” using wildcard “*”. When you click the “Apply rule” button the Target name will be filled for the objects to be duplicated.

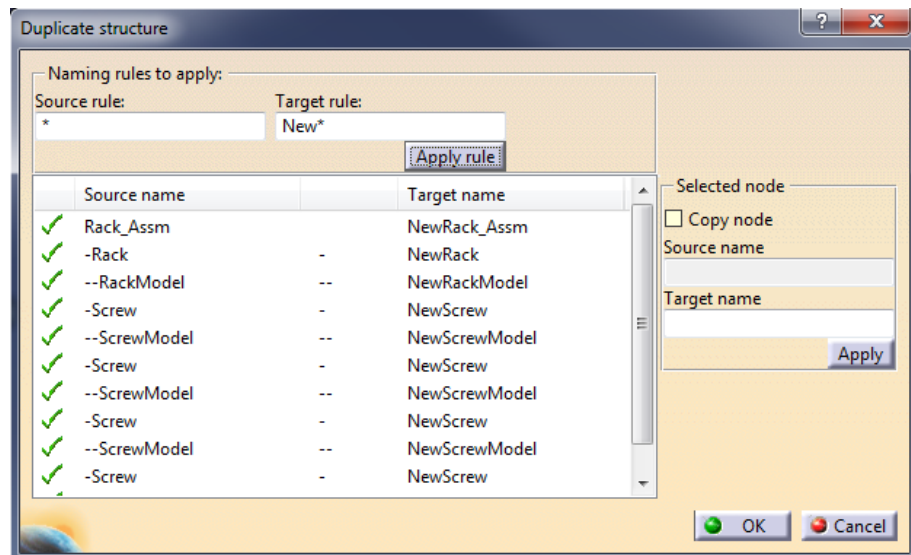

Picture 146: Example with small substructure – Filled Target names

When you click on “OK” the structure will be duplicated (see *Picture 147: Duplicated substructure in new CATIA window*).

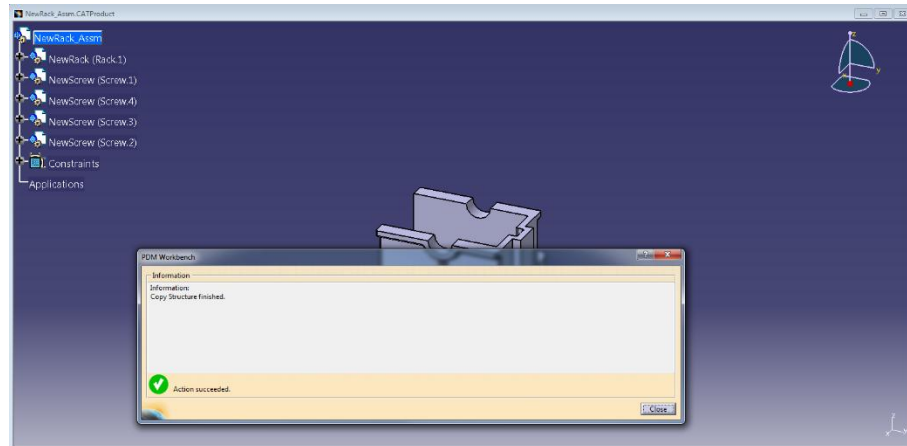

Picture 147: Duplicated substructure in new CATIA window

The duplicated substructure will be opened in a new window.
The new structure has to be synchronized in Aras Innovator.

Variant B - Duplicate Structure enhancements

There are some new functionalities in the Duplicate structure dialog:

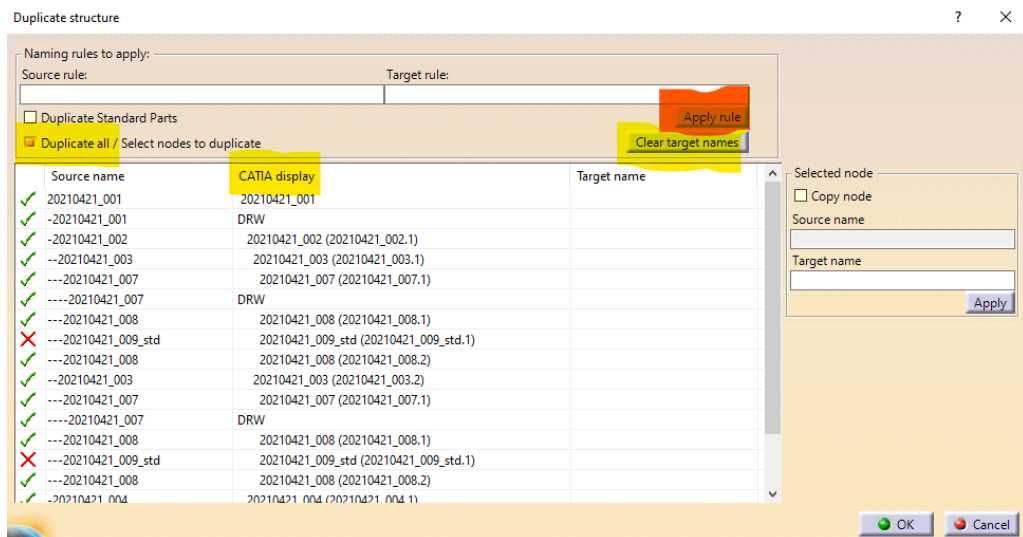

Picture 148: New function in the “Duplicate structure” dialog

1. **Apply rule**
This function was changed. Now you can use the rule to create new target names multiple times. The target name is only modified if the rule hits the source name. If the source name is not hit by the rule, the target name will stay unchanged.
2. **Clear target names**
This function clears all target names.
3. **CATIA display**
This column shows the same text, like the nodes in the CATIA structure tree.
4. **Duplicate all / Select nodes to duplicate**
By default all nodes except Standard Parts are selected to be duplicated. If you only want to duplicate some dedicated nodes and their path to root, you can uncheck the box. In this case, all nodes are excluded from the duplicate action. You can select the specific nodes and enable the “Copy node” manually.

It is possible to disable the “CATIA display” column. In this case the original column of the “Duplicate Structure” dialog is activated.

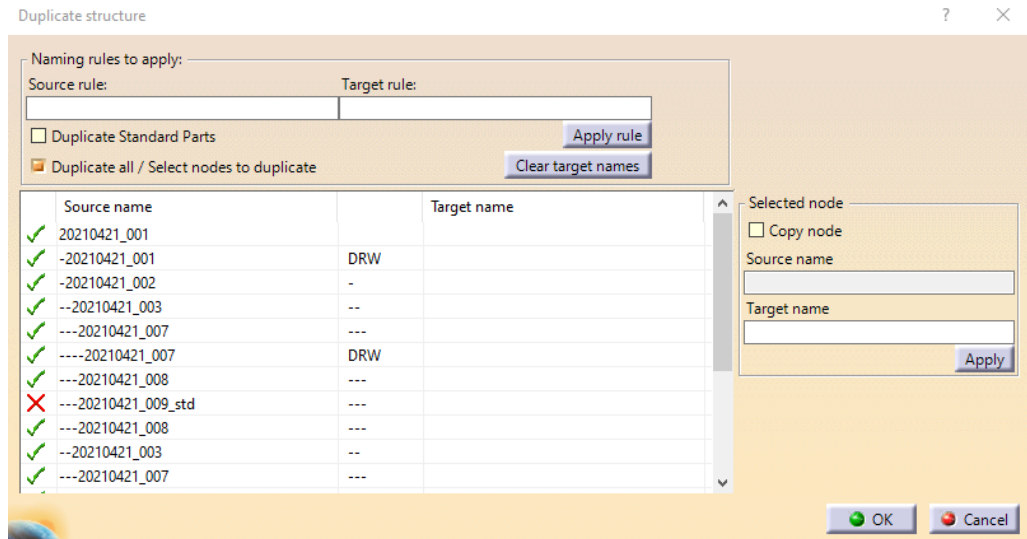

Picture 149: “Duplicate Structure” dialog, hide “CATIA display” column

Create Relation between Windows

You might modify the PDM structure by adding existing objects from several PDM Workbench windows to the PDM structure in another PDM Workbench window.

You select the object you want to copy and click the right mouse button to get the context menu. Then you select the context action “Copy” (see *Picture 150: Action “Copy” between windows*). Of course, you also can use the short cut “CTRL+C”.

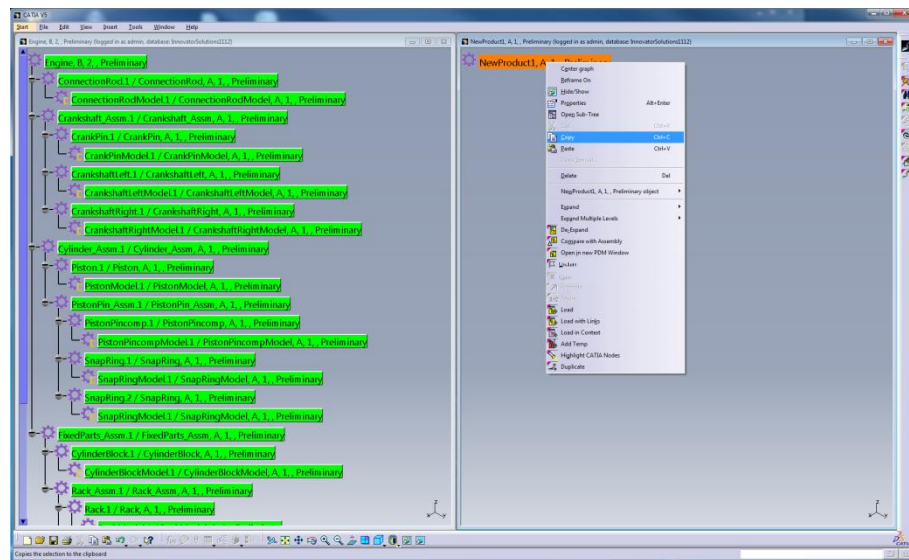

Picture 150: Action “Copy” between windows

Then you select the object where you want to add the copied object to and click the right mouse button to open the context menu. You select the context action “Paste” (see *Picture 151: Action “Paste” between windows*). Of course, you also can use the short cut “CTRL+V”.

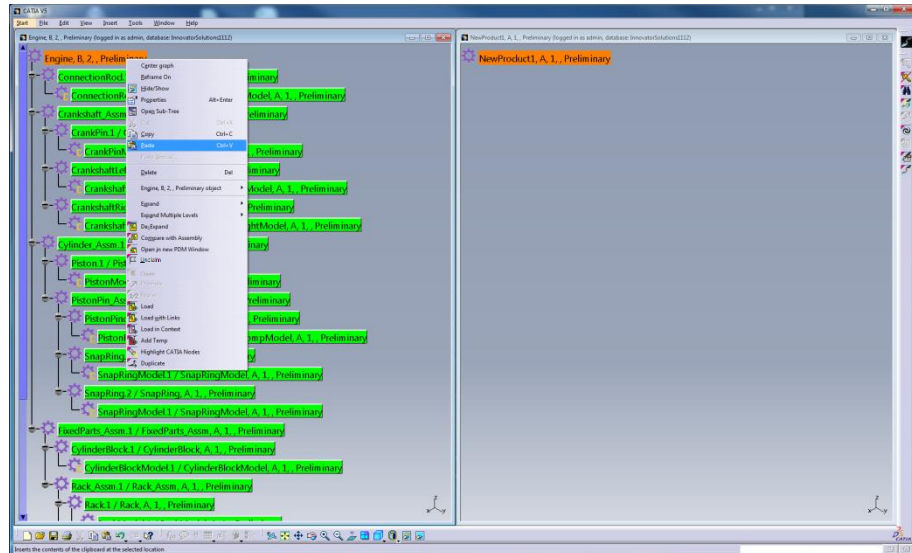

Picture 151: Action “Paste” between windows

You specify the relation you want to create in the structure between the two objects (see *Picture 152: Select the new relation*) once there is more than one relation type available. In the dialog window you see all relations possible between the two objects. In case you want to add the Assembly object in the structure to another Assembly object then you might choose the “Part BOM” relation for example. The dialog will not appear if there is only one relation type available.

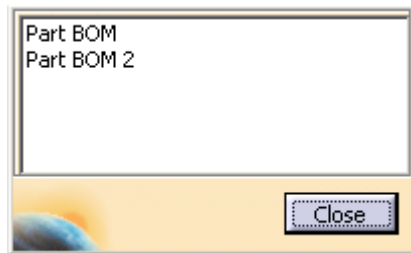

Picture 152: Select the new relation

The instance object gets inserted into the existing PDM structure tree and the new relation gets created in the PDM system (see *Picture 153: PDM structure with inserted object*).

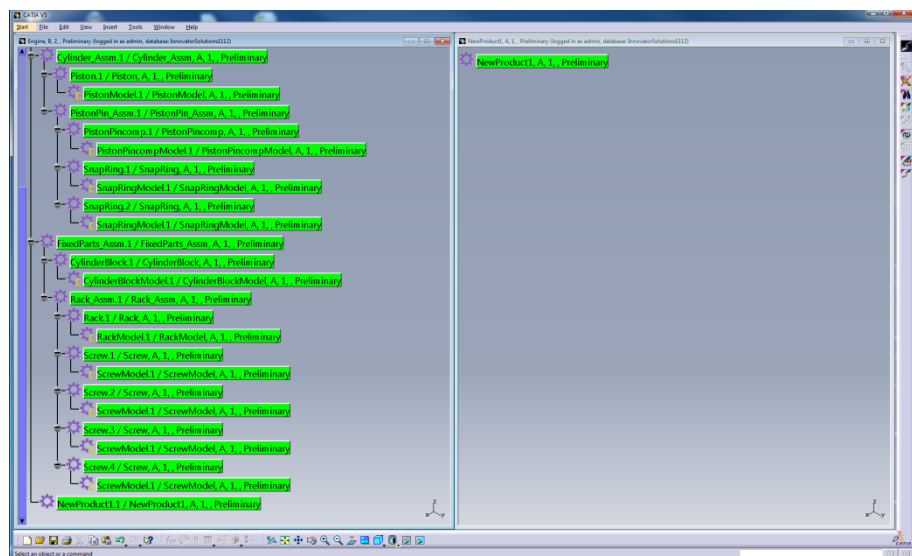

Picture 153: PDM structure with inserted object

Create CAD in Parent

It is possible to create a new CATPart and CATProduct CAD Document (or Part item, in the BOM Part Structure Data Model) directly in the CATProduct structure.

The “PDM Workbench” context menu in the CATIA window has the action “PDM Create in Context” (see *Picture 154: Action “PDM Create in Context”*).

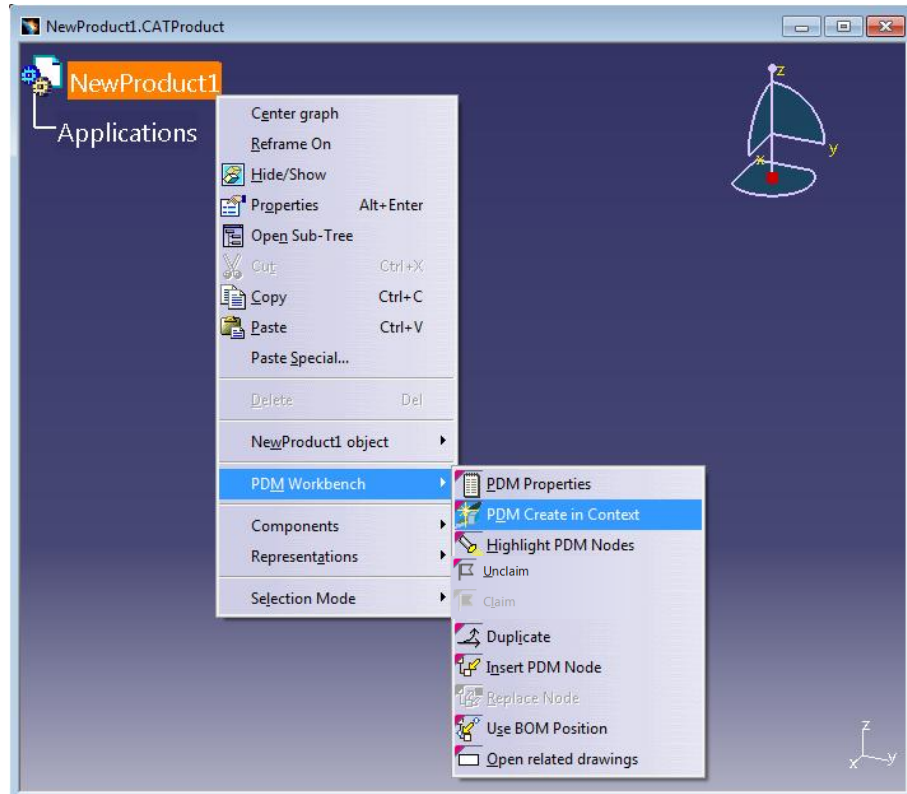

Picture 154: Action “PDM Create in Context”

Starting this action has the same effect as the “Create” toolbar action (see *Picture 156: Action “Create”*), except that only “CATPart” and “CATProduct” are selectable in the list (see *Picture 155: Create in Context – Select object type*).

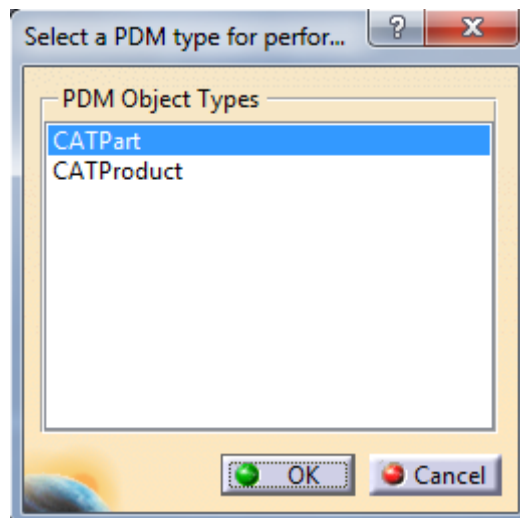

Picture 155: Create in Context – Select object type



Create

Picture 156: Action “Create”

After the action has completed the PDM items which correspond to the newly created CATPart or CATProduct node in the CATProduct structure have been created (see *Picture 157: Created object* and *Picture 158: Update result window for create object*).

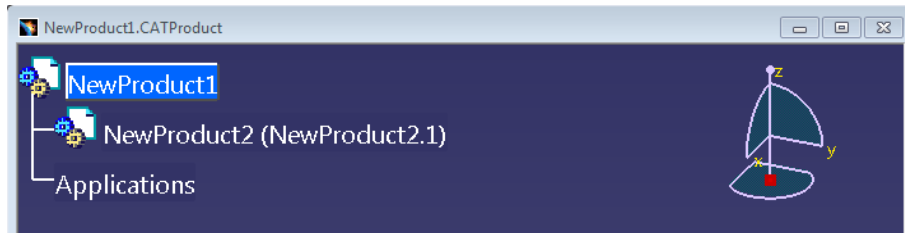

Picture 157: Created object

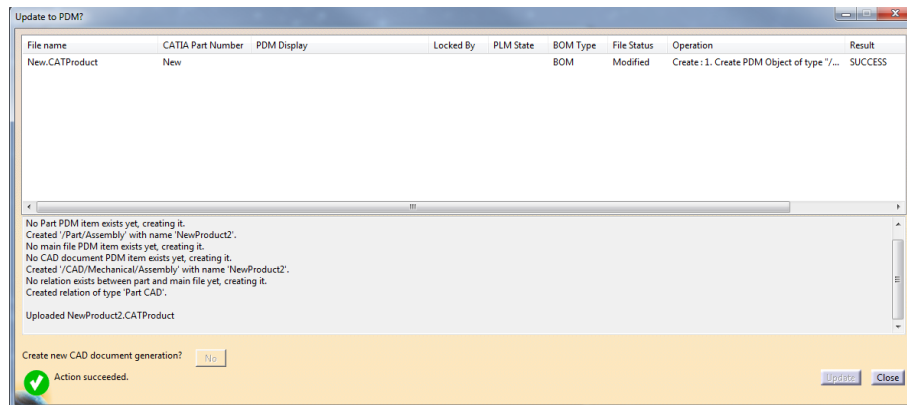

Picture 158: Update result window for create object

Starting the Update command will link the newly created PDM item to the loaded structure (see *Picture 159: Update window for create relation* and *Picture 160: Update result window for create relation*).

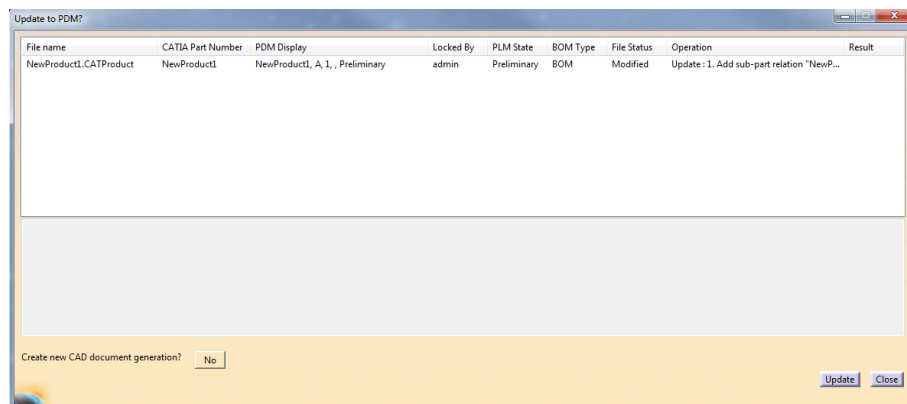

Picture 159: Update window for create relation

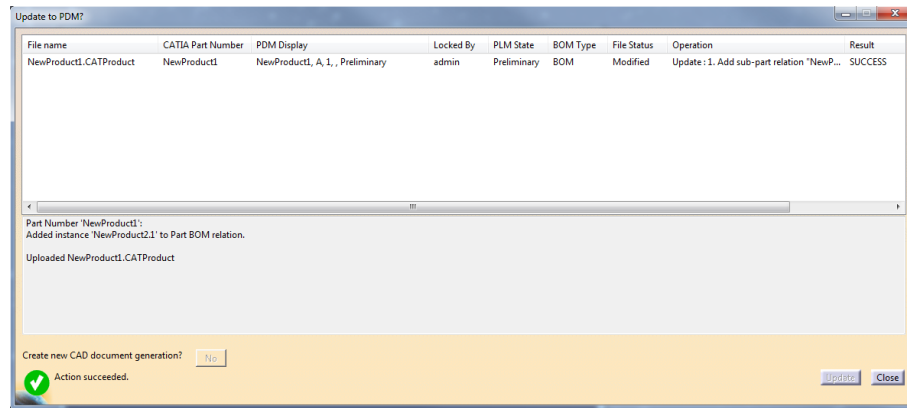

Picture 160: Update result window for create relation

Update

The “Update” functionality can be used to create, to complete, or to update the product structure in the PDM system based on the geometry in the CATIA V5 window.

If a Part Number can be changed during Update (autaname or manual input), the Part Number of the CATPart or CATProduct must not be controlled by internal CATIA business logic like knowledge ware.

You can start the “Update” process by clicking on the “Update” icon .

An “Update to PDM” dialog opens and asks to confirm the described actions. In this example the CATIA documents will be created (see *Picture 161: Confirm the “Update” (with Create) action*).

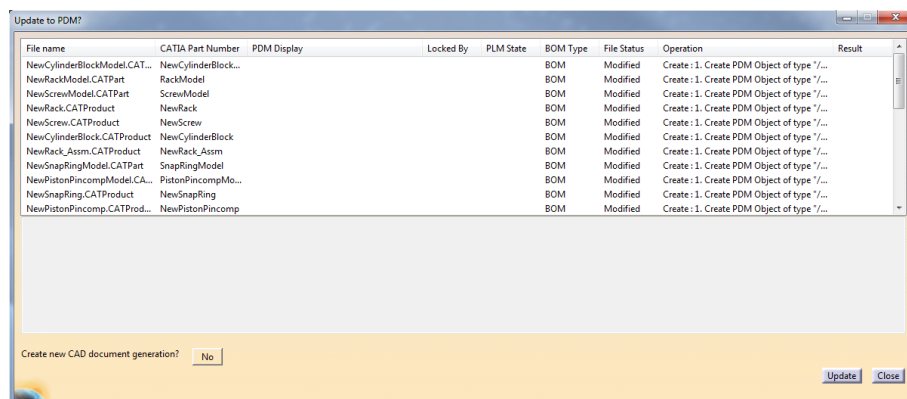

Picture 161: Confirm the “Update” (with Create) action

The progress of the Update will be shown with the progress bars (see *Picture 162: Update – progress bars*).

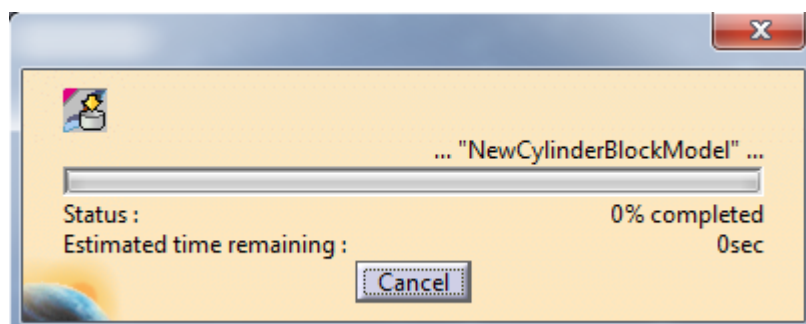

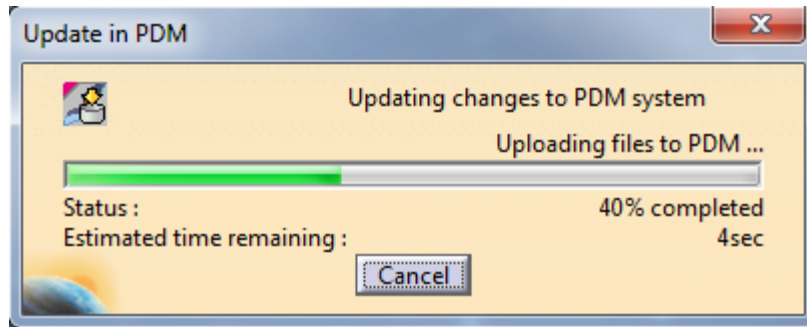

Picture 162: Update – progress bars

When the “Update” process has finished you are informed about the actions that have been performed. The related instances and the created objects are reported in the information window (see *Picture 163: Objects are updated (with Create)*).

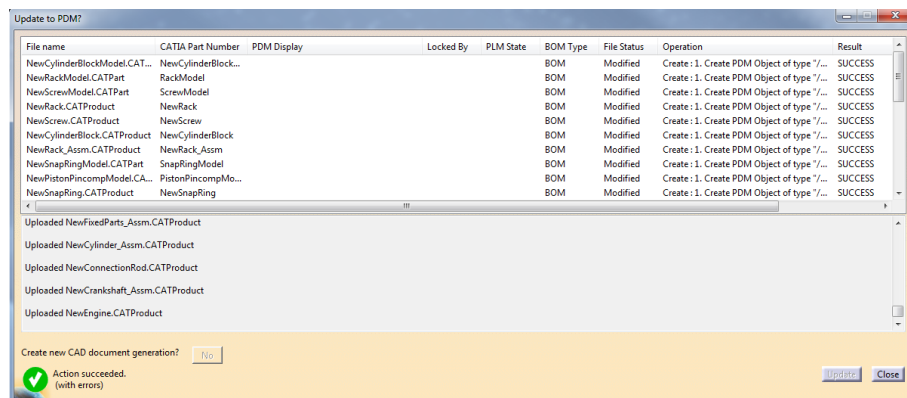

Picture 163: Objects are updated (with Create)

If there are no objects to be created then it will only be asked if you want to update (see *Picture 164: Confirm the “Update” action*).

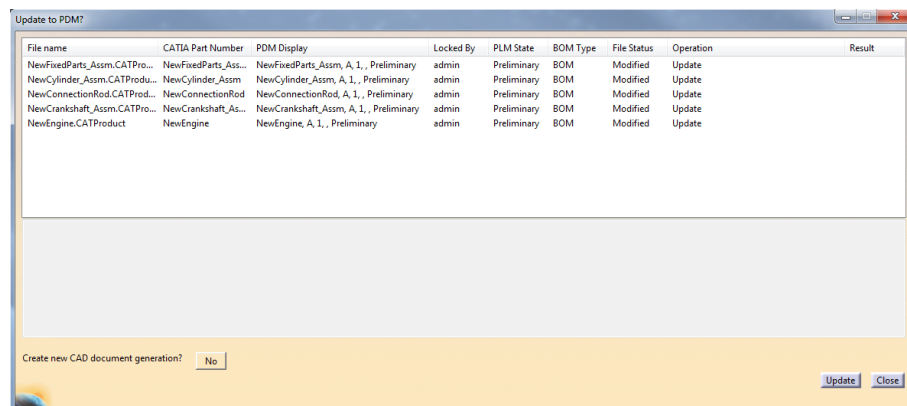

Picture 164: Confirm the “Update” action

When the “Update” process has finished you are informed about the actions that have been performed (see *Picture 165: Objects are updated*).

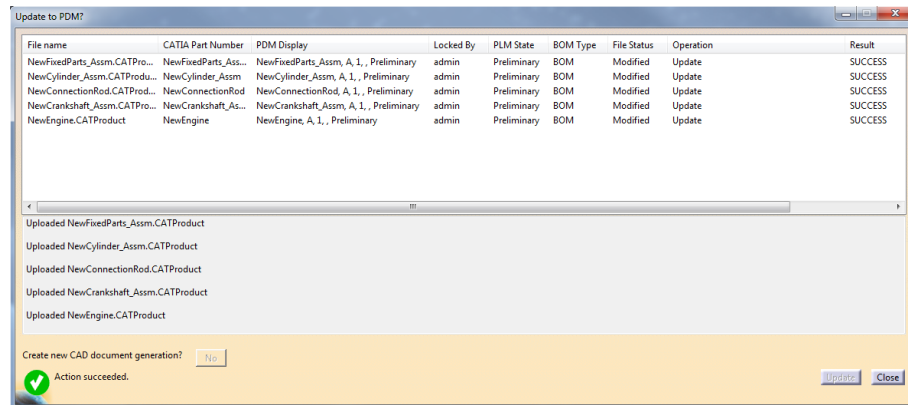

Picture 165: Objects are updated

Option to block the Update if linked File is not saved

When the user tries to update a CATDrawing which has links to CATParts that are loaded in the CATIA session, or a CATPart which has reference links to other CATParts, then the information to update those CATParts first is presented:

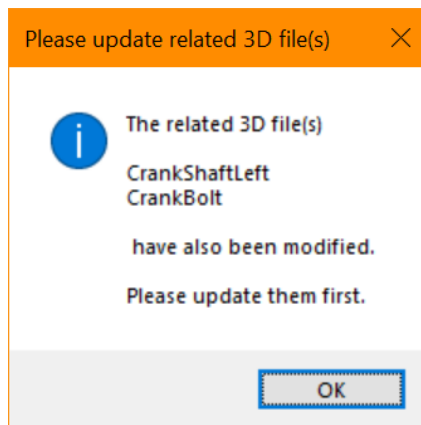

Picture 166: Information about CATParts to be updated

Option: "Update to PDM" Dialog only shown if new Documents to be created exist

It can be configured that the "Update to PDM" dialog is only shown if there are new items to create, or if there are warnings or errors during the execution.

Add newly created and updated Part or CAD Items to existing Items

It is possible to link the Part and CAD items during the "Update" process to an existing item. This can be done by using a custom method which is called at the end of the "Update" process.

Examples:

1. The user wants to link a new top-level item to a selected Folder/Project item.
2. The user has several Change Items he has to work on. During the "Update" process the user selects the current Change Item he is working on from a list of his Change Items. This Change Item can be related to all updated Part or CAD items. This gives the possibility to understand later why a certain change was made.

The following use case shows a sample implementation to link a new top-level item to a selected Folder/Project item.

With the correct configuration the user can select an entry from a list of folder names in the “Update to PDM” dialog. The list is the one returned by the custom method defined by the setting “CustomMethod_PostProcUpdate”:

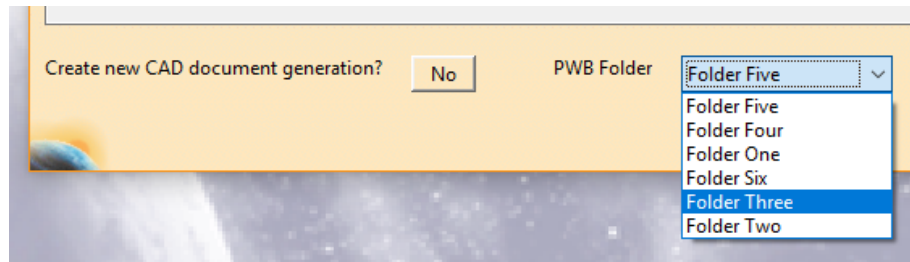

Picture 167: Folder list

The item that the user has selected will be the one that the newly created root Part item will be related to.

If the folder item and relationship is defined in the Schema file the user can expand the relations in the PDM structure window and find out which folder, if any, a Part item is related to, and which Part items are related to a folder:

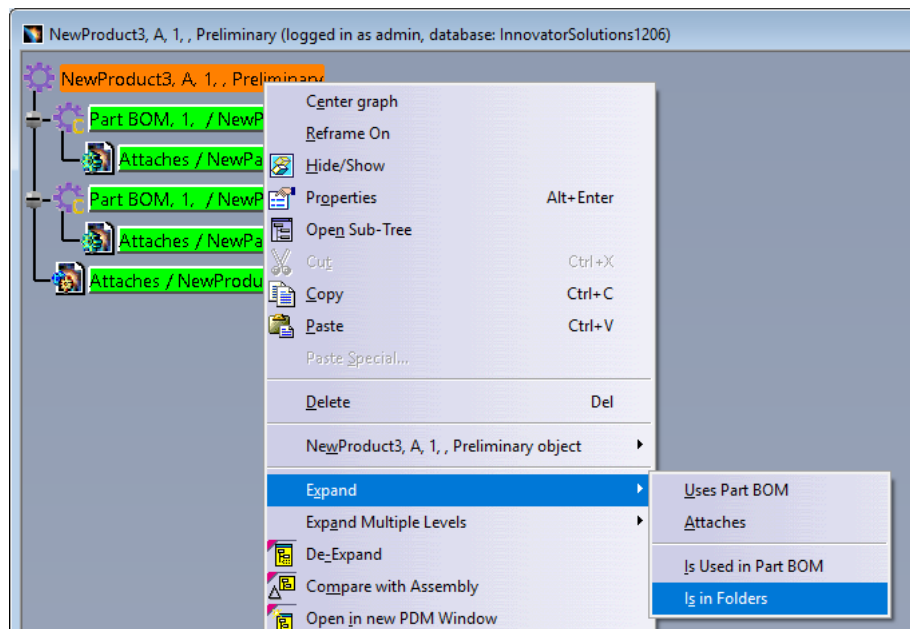

Picture 168: Expanding “Is in Folders” in the PDM structure window

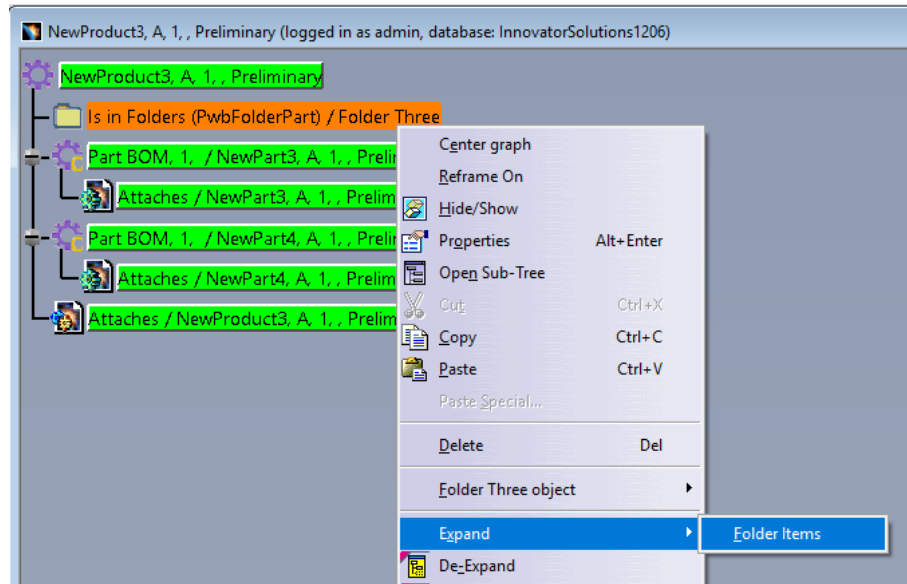

Picture 169: Expanding “Folder Items” in the PDM structure window

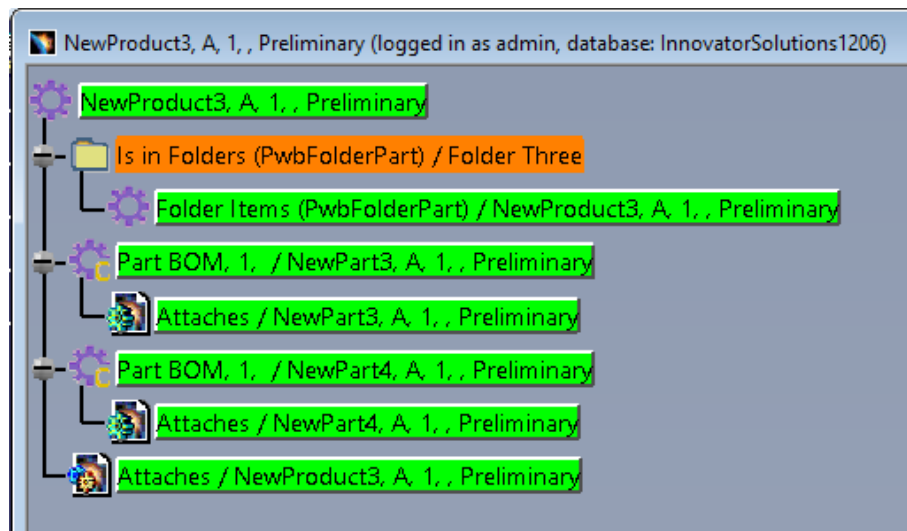

Picture 170: Expanded folder items in the PDM structure window

Deny Create of CAD at top-level Structure in BOM Part Structure Data Model

It is possible to create a top-level Part structure in Aras Innovator without attached CADs. The structure can be loaded to CATIA, the missing CATIA files are created on the fly in CATIA.

This functionality allows to prevent the update of the top-level Part structure, including the save of the “On the fly” created CATIA files.

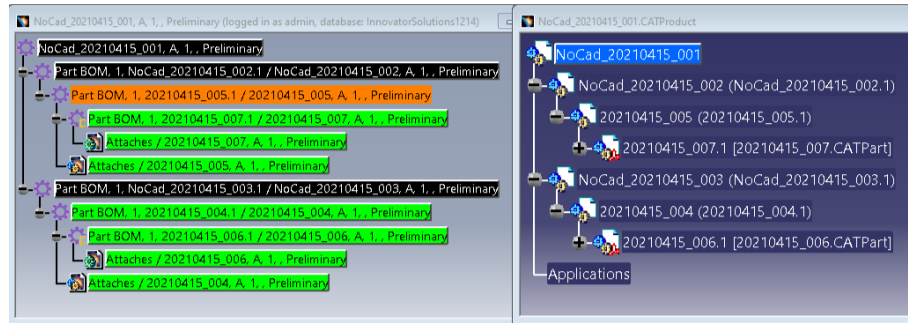

Picture 171: Non-CAD top-level structure with on the fly created CATProducts

During update, the on the fly created CATProducts are skipped.

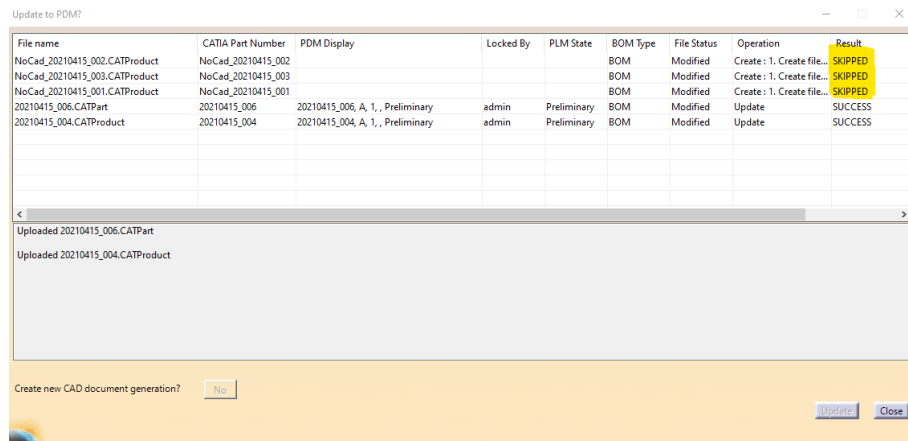

Picture 172: Update non-CAD top-level structure -> Result SKIPPED

Select Type of additional Parts in CAD Document Structure Data Model

This functionality is only available in the CAD Document Structure Data Model.

It is possible to create an additional Part item in Aras Innovator while creating a CAD Document during the PDM update. By default, there is a configured part type that will be created in this case.

You can select a specific part type to be created (see *Picture 173: Action "Set PDM Type to"*).

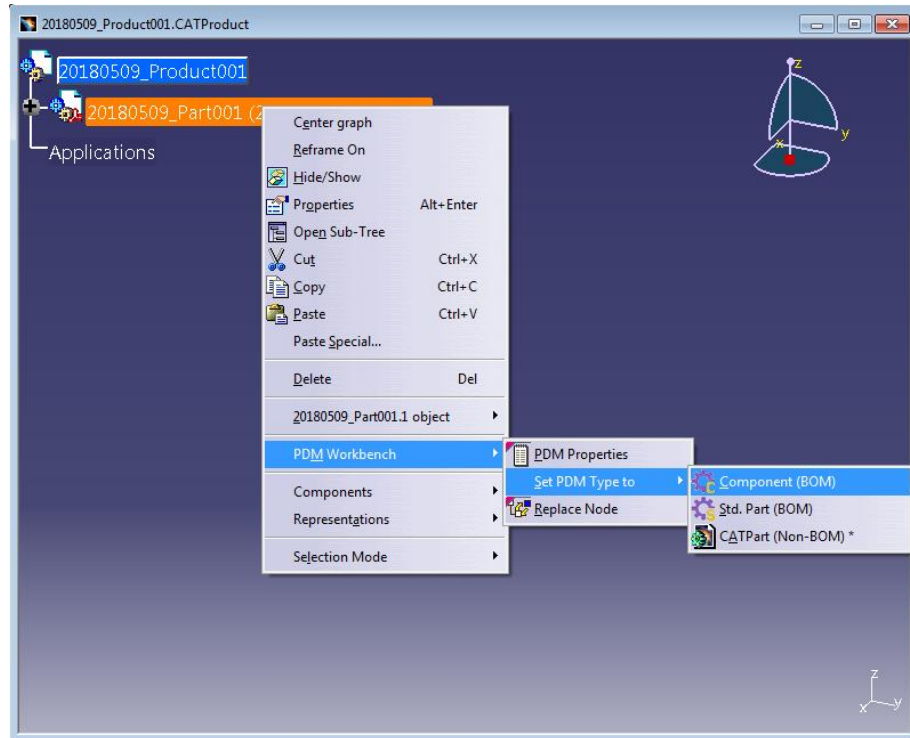

Picture 173: Action “Set PDM Type to”

When updating a CATProduct structure the type of the additional part will be shown in the “Operation” column of the “Update to PDM” dialog (see *Picture 174: “Update to PDM” dialog for CATProduct structure*). The “Create corresponding BOM parts” button will be hidden.

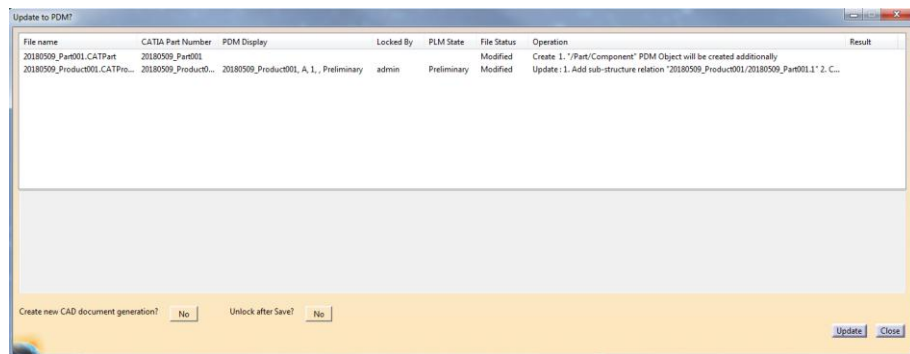

Picture 174: “Update to PDM” dialog for CATProduct structure

When updating a single CATPart the “Create corresponding BOM parts” button will be shown (see *Picture 175: “Update to PDM” dialog for CATPart document*). If a BOM type was selected for the CATPart, the button will be deactivated, otherwise the “Create corresponding BOM parts” button will be active. In this case the default part type will be created for the CATPart when setting the button to “YES”

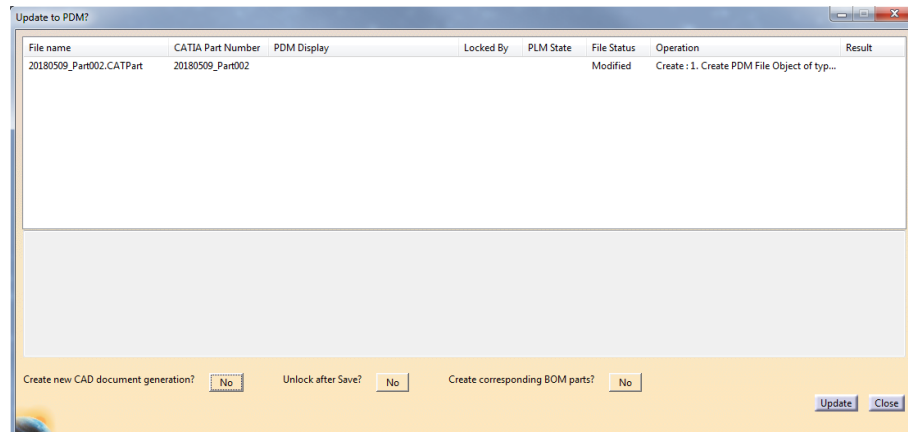

Picture 175: “Update to PDM” dialog for CATPart document

Constraints:

- It is only possible to select a BOM type if the parent Product is marked to have an additional BOM part item or if the parent CATProduct was loaded from PDM.
- If you switch the type of a CATProduct from BOM to NON-BOM all children will be switched to NON-BOM.

As there is no context menu for a single CATPart you have either to use the default part type for single loaded CATParts, or you have to put the CATPart in a temporary CATProduct and set the type of the additional PDM part item before updating the single CATPart.

Non-BOM CATParts and CATProducts

In the BOM Part Structure Data Model it is possible to define CATParts and CATProducts in the CATIA structure to be defined as not BOM-relevant. In this case no corresponding part items will be created in PDM.

Before a CATProduct structure is created in PDM it is possible to change the wanted PDM type from a part type like Assembly or Component to the CATIA file type (see *Picture 176: Setting a CATProduct to the non-BOM type*).

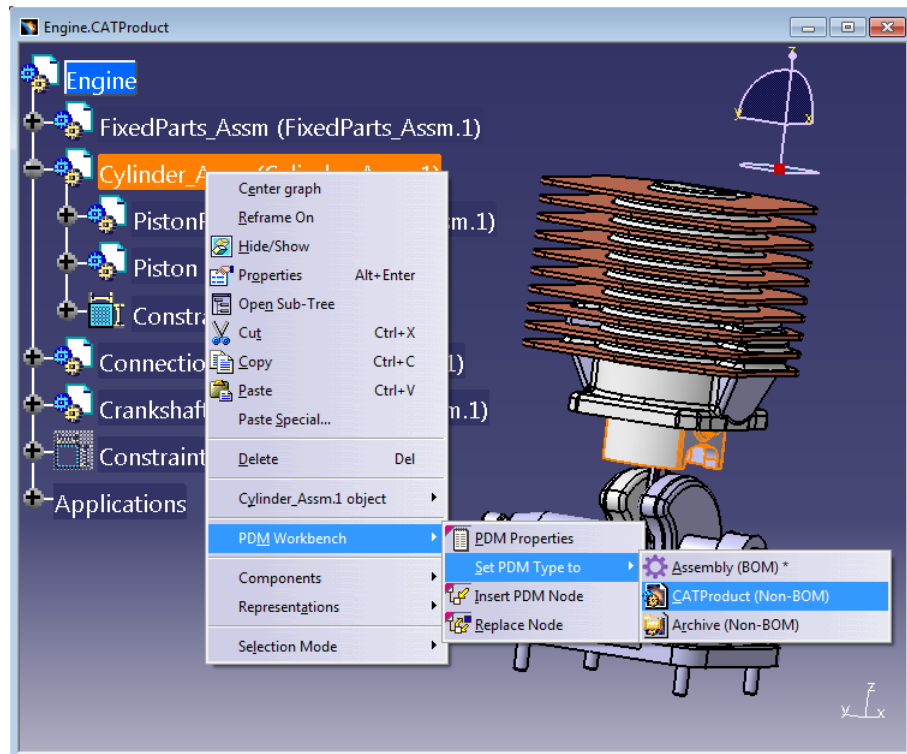

Picture 176: Setting a CATProduct to the non-BOM type

In that case all sub-nodes of the CATProduct also become non-BOM.

CATParts also can be changed to the non-BOM type (see *Picture 177: Setting a CATPart to the non-BOM type*).

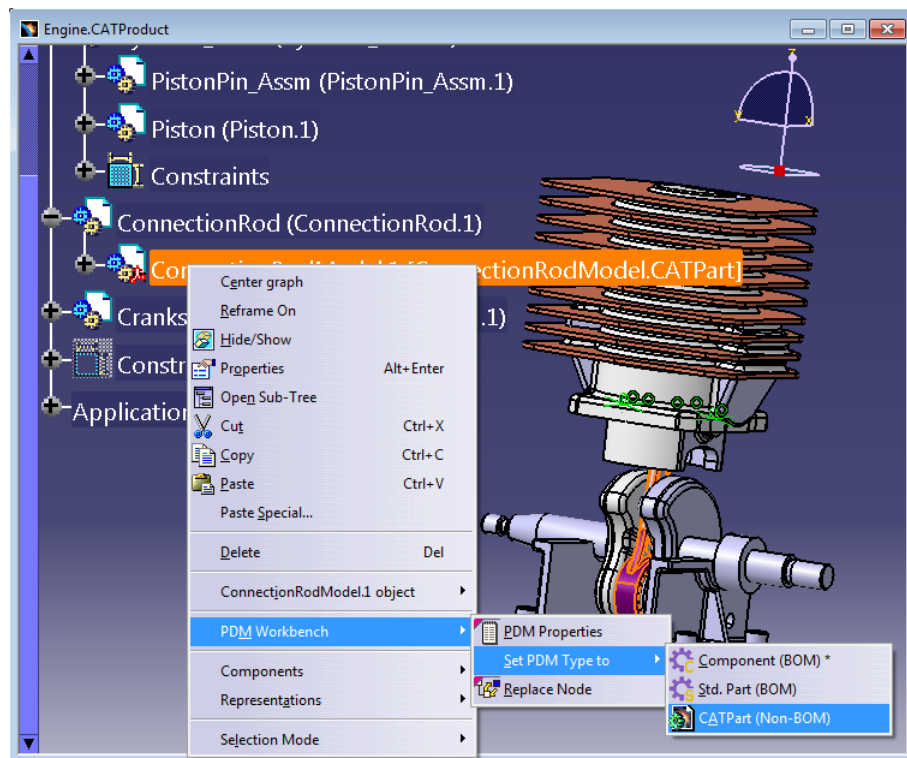

Picture 177: Setting a CATPart to the non-BOM type

In the “Update to PDM” dialog the BOM types can be verified (see *Picture 178: “Update to PDM” dialog with non-BOM part items*).

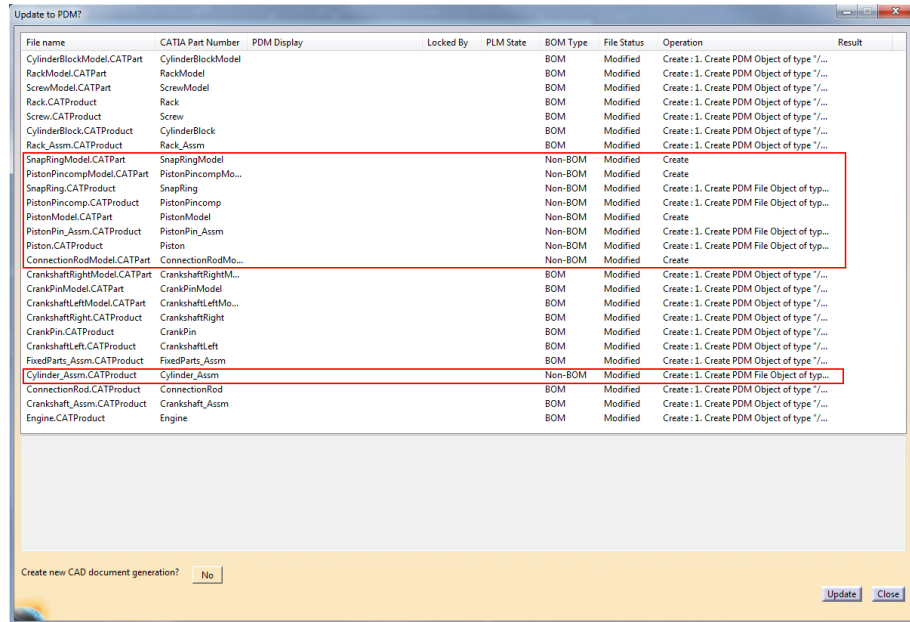

Picture 178: "Update to PDM" dialog with non-BOM part items

The result is a structure in PDM which contains both Part structures and CATIA Document structures (see *Picture 179: Resulting PDM structure*).

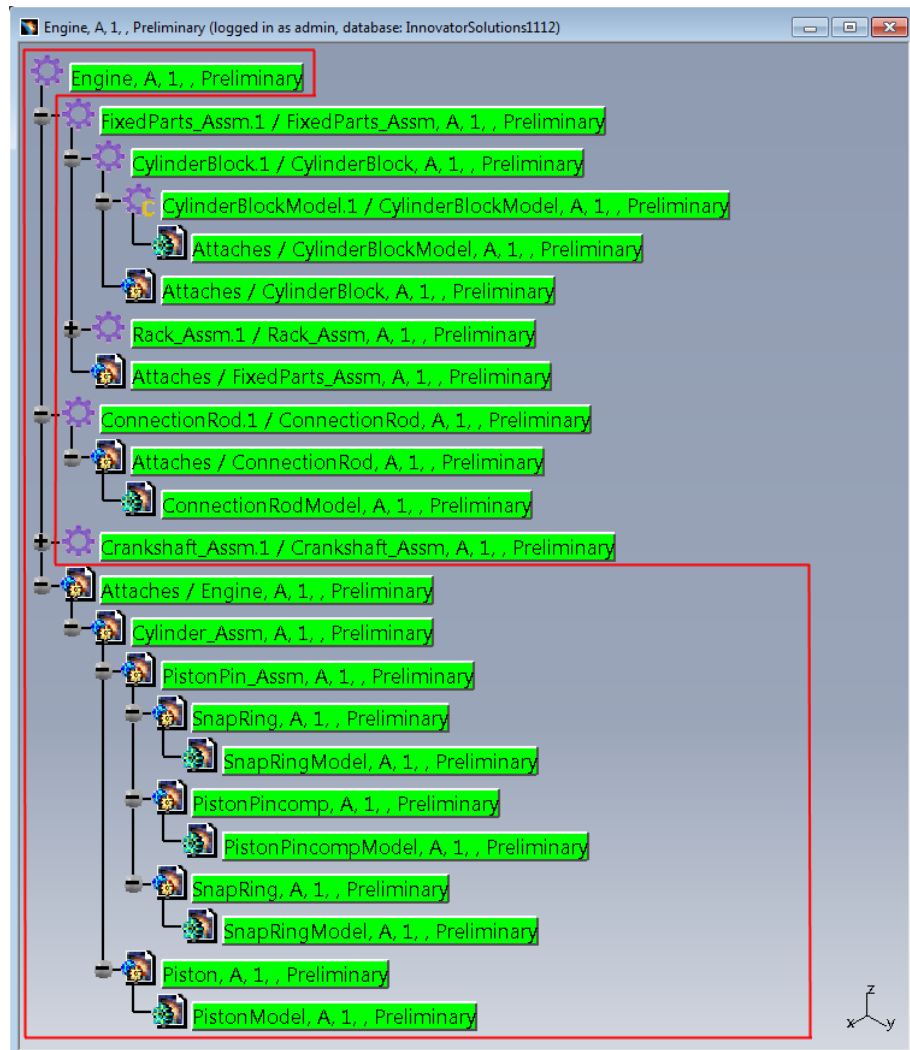

Picture 179: Resulting PDM structure

When nodes are added to or removed from the non-BOM CAD Document structure, “Update” synchronizes the changes in the CATProduct structure to the non-BOM CAD structure, just like to the BOM part structure.

Attach additional non-BOM CATParts to Part

When using the BOM Part Structure Data Model only one CATPart can be attached to an Aras Innovator Part (Component). It can be configured to allow additional non-BOM CATParts attached to an Aras Innovator Part (Component).

When loading the Component, the additional CATParts are only loaded into the CATIA session if they are referenced by a CATIA file which is part of the normal BOM structure. It is also possible to load a non-BOM CATPart directly.

To create a non-BOM CATPart it is possible to set the PLM type of a CATPart. There is also a functionality to relate the active non-BOM CATPart to an Aras Innovator Part.

To use the functionality the usage of non-BOM CATIA files in BOM mode must be enabled.

To create a non-BOM CATPart and attach it to an Aras Innovator Component:

Set PLM type of active CATPart to “Non-BOM”.

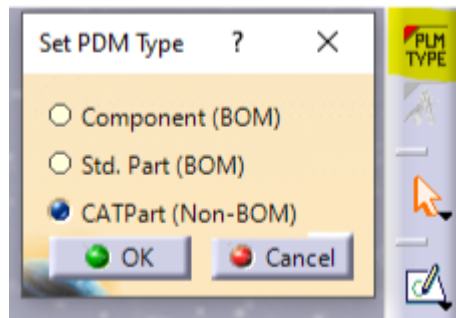

Picture 180: Select PDM type of CATPart

Then use the normal “Update” functionality to save the CATPart in Aras Innovator:

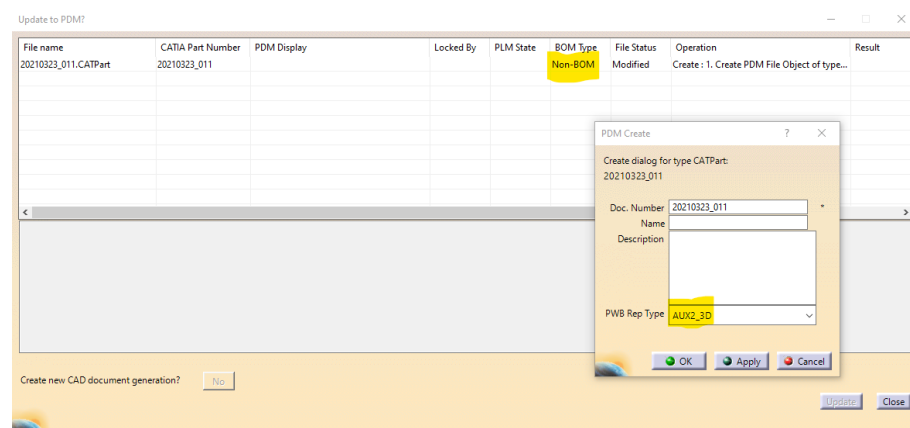

Picture 181: Update non-BOM file in BOM Part Structure Data Model

Later you can attach the already registered CATPart to an Aras Innovator Component by using the new function “Relate active non-BOM CATPart to Part”:

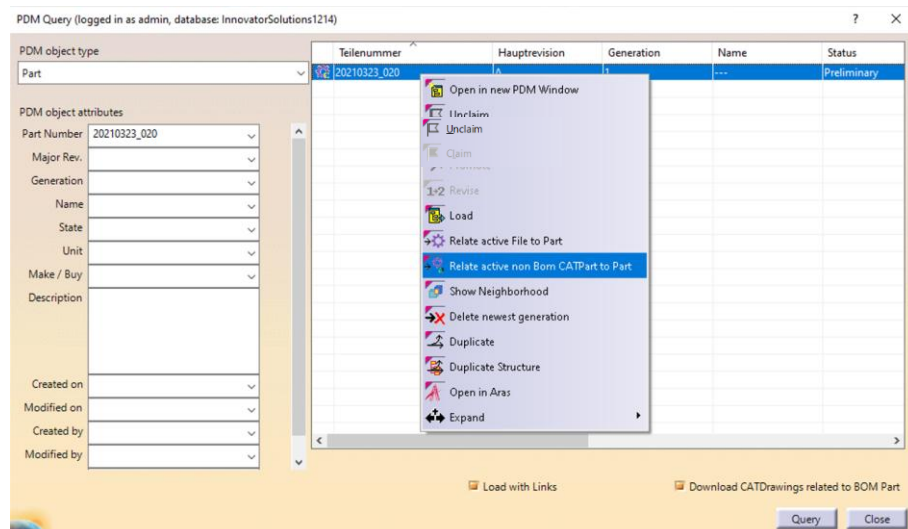

Picture 182: Relate active non-BOM File to Part

It is also possible to relate a not yet registered CATPart as non-BOM CATPart to the selected Aras Innovator Part (this function has to be enabled separately). In this case the CATPart is registered using its current Part Number and the first NonBom3DRepType. There is no additional user action.

If you use the non-BOM CATParts as linked reference geometries in the BOM structure, it may be useful to open these files when opening the product structure. Therefore, the new PDM Workbench Options setting “Open linked Documents in own Window” is available for the BOM Part Structure Data Model:

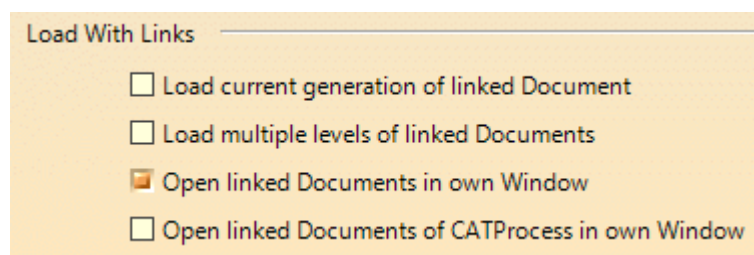

Picture 183: “PDM Workbench Options” dialog “Open linked Documents in own Window”

Reconnect at Update

Up to PDM Workbench version 9.0 the “Reconnect” functionality was combined with the “Auto Name” functionality. Now the “Reconnect” functionality is no longer connected with the “Auto Name” functionality.

This functionality can be used for an initial import of existing CAD data into Aras Innovator.

It is possible to reconnect CATParts and CATProducts inside a structure loaded from disk to already existing CAD Documents in Aras Innovator even if the CATIA files in Aras Innovator were renamed (rule based) during the first import. When a CATPart/CATProduct is reconnected, the external file is not saved to Aras Innovator.

Import Product Structure

Open a structure from disk and use “Update” to save the structure into Aras Innovator. If some of the files may be already stored in Aras Innovator, select “Import with Reconnect” before performing the update (see *Picture 184: “Update to PDM” dialog with “Import with Reconnect” button*).

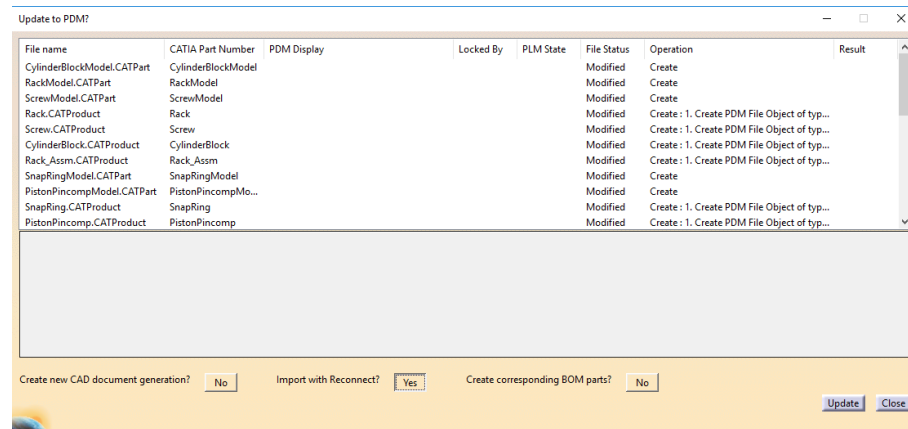

Picture 184: “Update to PDM” dialog with “Import with Reconnect” button

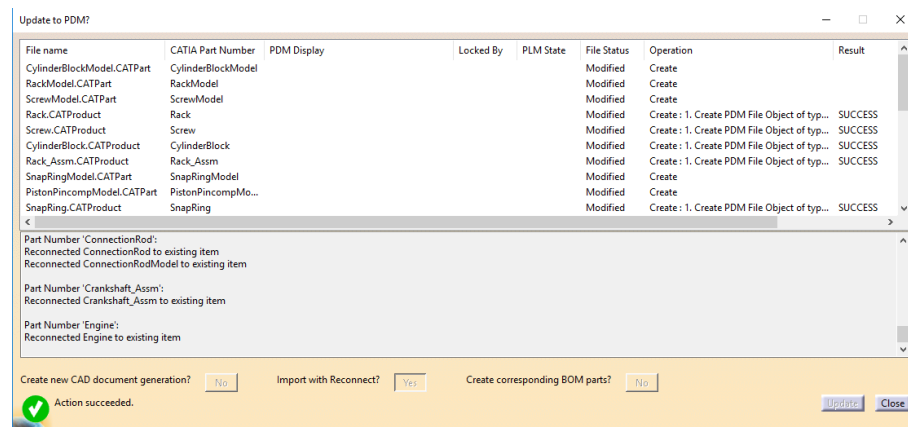

Picture 185: Messages about reconnected items

To check if the reconnected Documents in Aras Innovator use the same content like the imported files on disk, you have to close all windows in CATIA and open the structure from Aras Innovator.

Import CATDrawing

CATDrawings itself are not reconnected in Aras Innovator, but the referenced CATProducts/CATParts may be renamed during import. Therefore, the following procedure can be used to import a CATDrawing without breaking the links.

Open the CATDrawing and use File→Desk to open the directly referenced CATPart(s)/CATProduct(s) (see *Picture 186: Opening referenced 3D geometry files*).

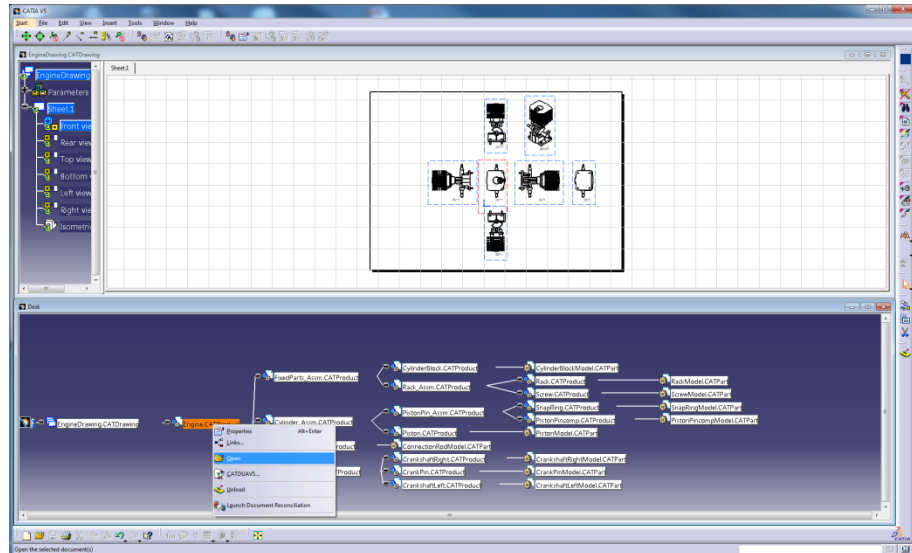

Picture 186: Opening referenced 3D geometry files

Update the opened structure like described in “Import Product Structure”. Do not close the renamed product structure after update (see *Picture 187: Reconnect referenced Product Structure*).

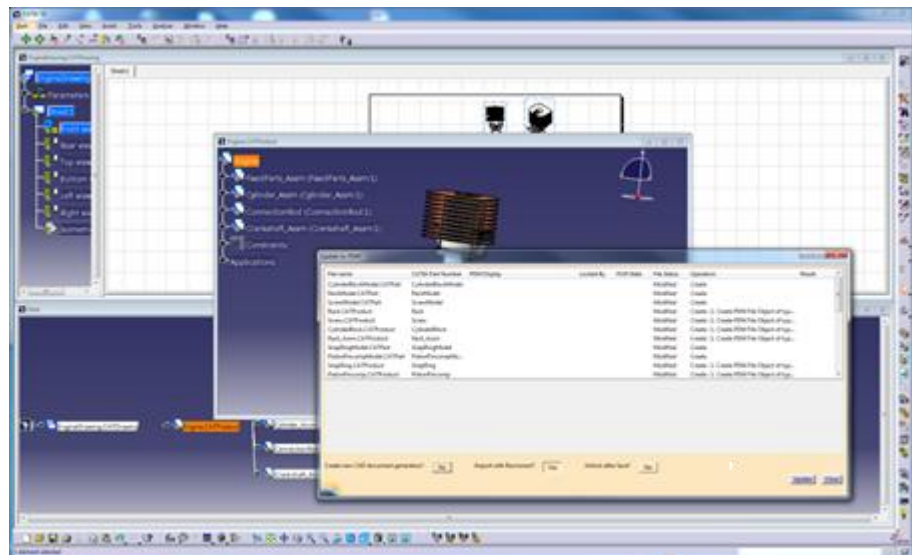

Picture 187: Reconnect referenced Product Structure

After save/reconnect the structure in Aras Innovator the CATDrawing activates the “Update current Sheet” button that indicates that the CATDrawing needs an update (see *Picture 188: Updating the current sheet*).

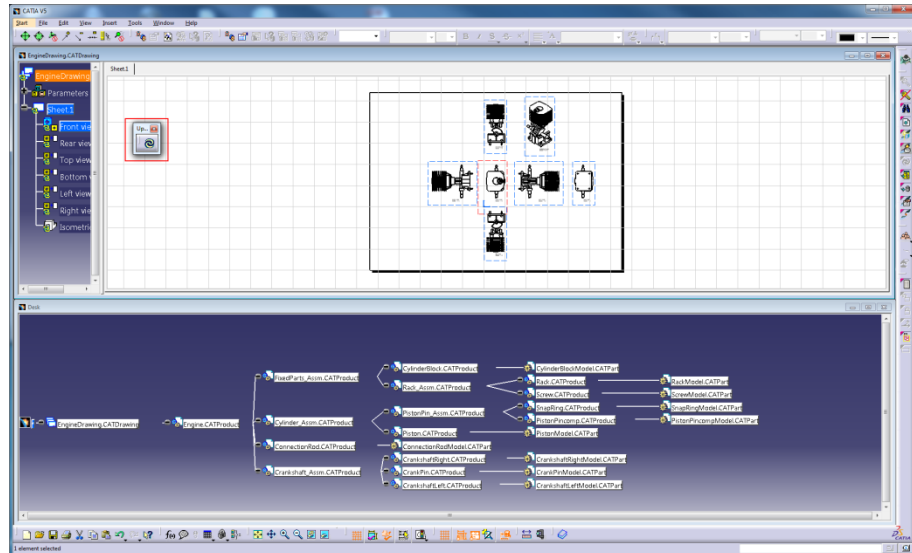

Picture 188: Updating the current sheet

Use the “Update current Sheet” command to make sure the drawing is clean.

Use the PDM Workbench function “Update” to save the CATDrawing in Aras Innovator. To save a CATDrawing in PDM do not select “Import with Reconnect”.

Show PDM Structure

When you have opened the geometry in CATIA V5 you have the possibility to show the corresponding PDM structure.

For this you have to click on the “PDM Structure” icon . Then a PDM Workbench window with the PDM structure will be opened (see *Picture 189: PDM structure for geometry*).

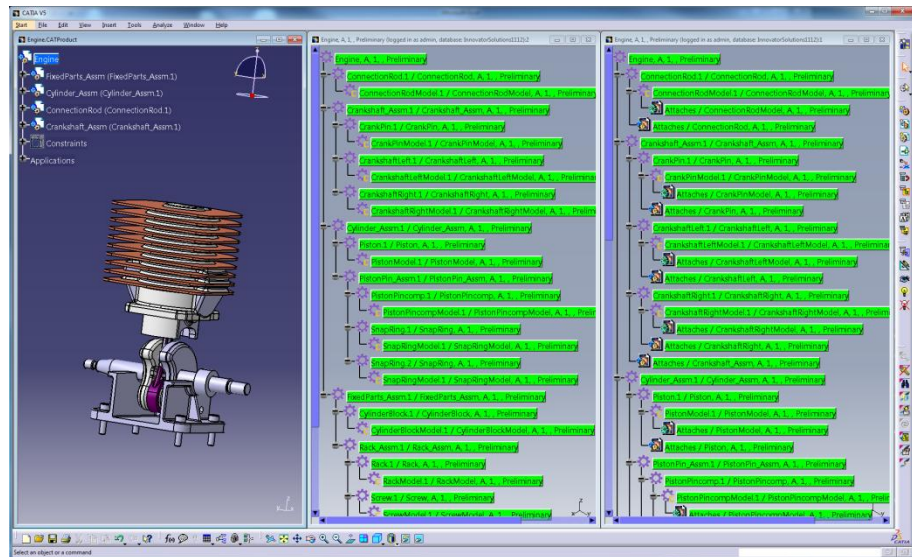

Picture 189: PDM structure for geometry

Please note that with BOM part structures, the expanded PDM structure (window in the middle) usually does not contain the related CATIA files, but the PDM structure displayed by “Show PDM Structure” does (right window).

Refresh PDM Structure

When you have made some actions on the geometry that have an impact on the status of the objects in the PDM structure, that are not displayed automatically, then you have to update the status display manually.

After the load of the geometry the status of the objects of the PDM structure is in the default state.

There are the following possible states:

- No background color: not owned by session user, no changes
- Green: owned by session user, no changes
- Yellow: owned by session user, dirty because of changes
- Red: not owned by session user, dirty because of changes
- Black: the object is finalized in the PDM (for example: released state)
- White: the object does not have the file in the PDM

The CATIA Part is owned by the session user and no changes. It is marked in green (see *Picture 190: PDM structure and geometry in CATIA V5*).

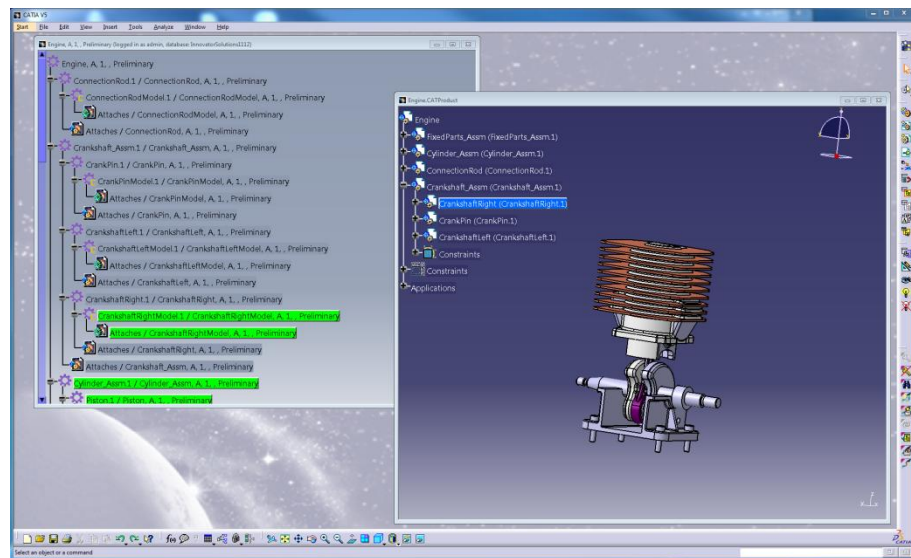

Picture 190: PDM structure and geometry in CATIA V5

In the CATIA V5 you can make some changes in the geometry (see *Picture 191: Making changes in the geometry*) that make the objects in the PDM structure dirty. This state change will not be displayed automatically.

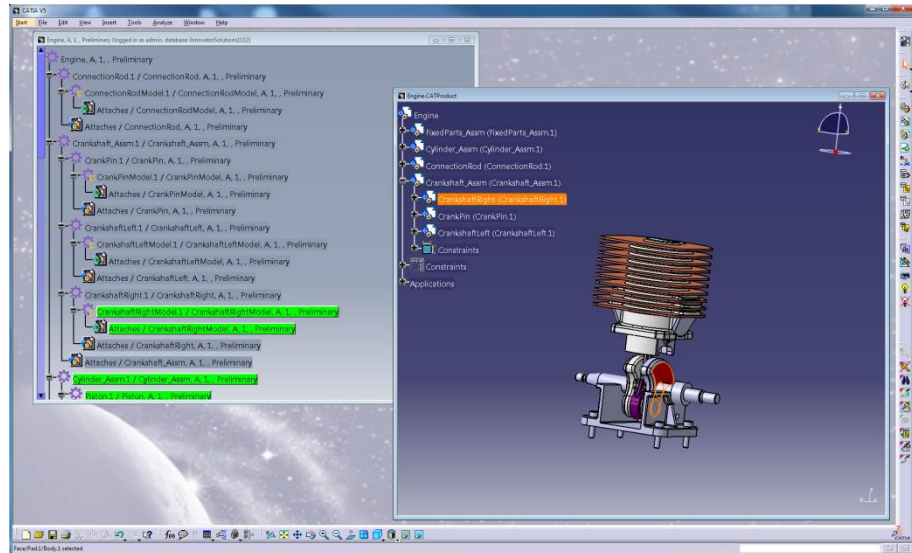

Picture 191: Making changes in the geometry

In order to display the changes, you have to click on the “Refresh PDM Structure” icon



. Then the status of the changed objects in the PDM structure will be updated.

Now e.g. the dirty object owned by the session user will be displayed in yellow in the PDM structure. The dirty objects on the way to the root are displayed in red because they are not owned by the session user (see *Picture 192: Refreshed PDM structure*).

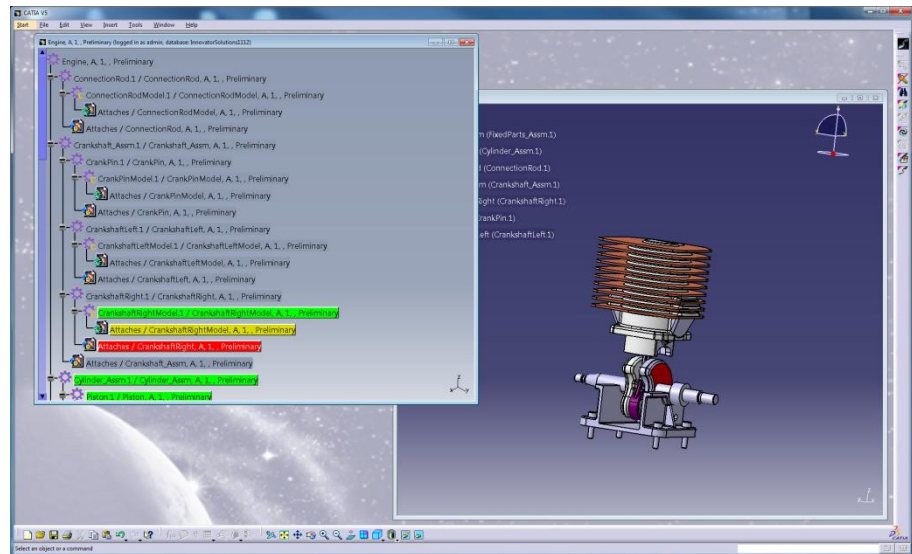

Picture 192: Refreshed PDM structure

“Refresh” is active in the Main Toolbar

This also applies to CATPart and CATDrawing windows.

That makes it possible to refresh the Claimed/Unclaimed status of a CATPart or CATDrawing CAD Document in the CATIA session.

PDM Status Information in the CATIA Tree

A PDM status information can be displayed on product structure nodes within the CATIA tree. These nodes show an additional icon mask and additional text and tooltip text corresponding to some information from the PDM system.

If configured by the administrator, a PDM status information is displayed on product structure nodes within the CATIA tree:

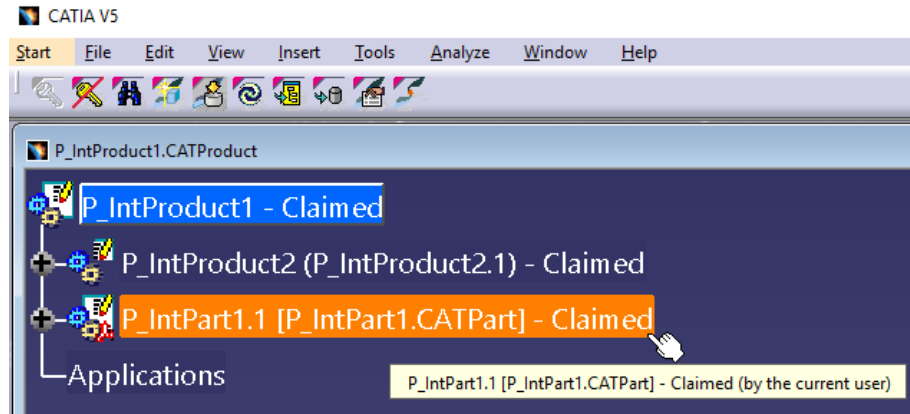

Picture 193: PDM status information in the CATIA tree

These nodes show an additional icon mask in the upper right corner of the icon and additional text and tooltip text corresponding to some information from the PDM system.

Highlight PDM Nodes

Sometimes it is important to find a PDM node when you are working on the corresponding object in the geometry, e.g. in order to claim the PDM object. Or you have selected an object in the PDM structure and want to see the corresponding object in the geometry.

For this you can select an object in the geometry and click on the right mouse button. The context menu opens and you have to choose *PDM Workbench* → *Highlight PDM Nodes* (see Picture 194: Action “Highlight PDM Nodes”).

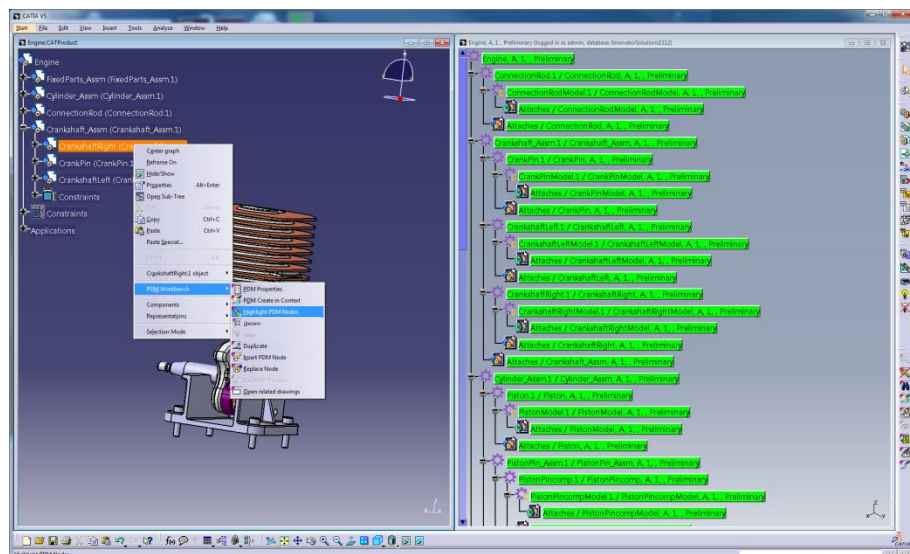

Picture 194: Action “Highlight PDM Nodes”

The PDM Workbench window will be displayed in the foreground and the objects that correspond to the selection in the geometry will be highlighted (marked) (see *Picture 195: Highlighted nodes in PDM structure*). If there is no PDM Workbench window opened, you will get a warning that you have to open the PDM structure first. It is important that you have only one PDM Structure window for this Part Number.

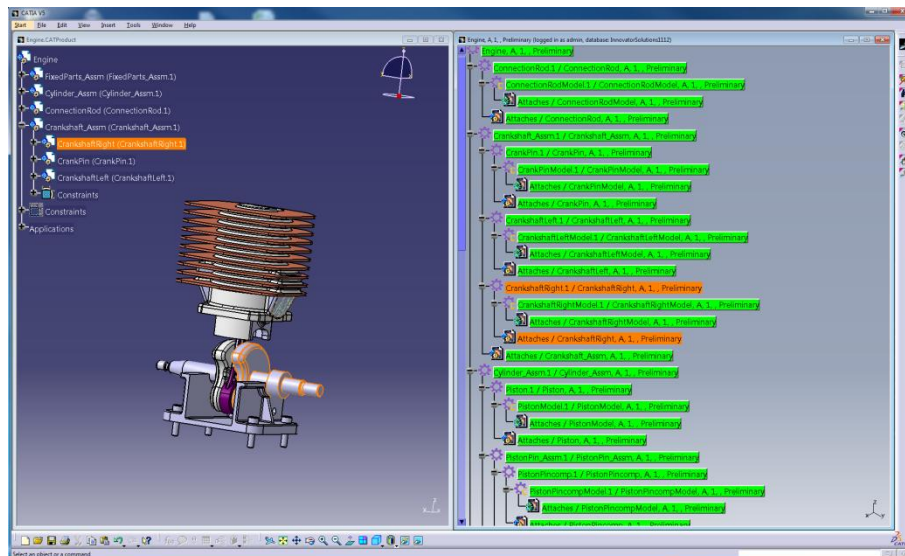

Picture 195: Highlighted nodes in PDM structure

This works in the opposite direction, too (see *Highlight CATIA Nodes*).

Highlight CATIA Nodes

Sometimes it is important to find a CATIA node when you are working on the corresponding object in the PDM structure, e.g. in order to claim the PDM object. Or you have selected an object in the geometry and want to see the corresponding object in the PDM structure.

For this you can select an object in the PDM structure and click on the right mouse button. The context menu opens and you have to choose *PDM Workbench* → *Highlight CATIA Nodes* (see *Picture 196: Action “Highlight CATIA Nodes”*).

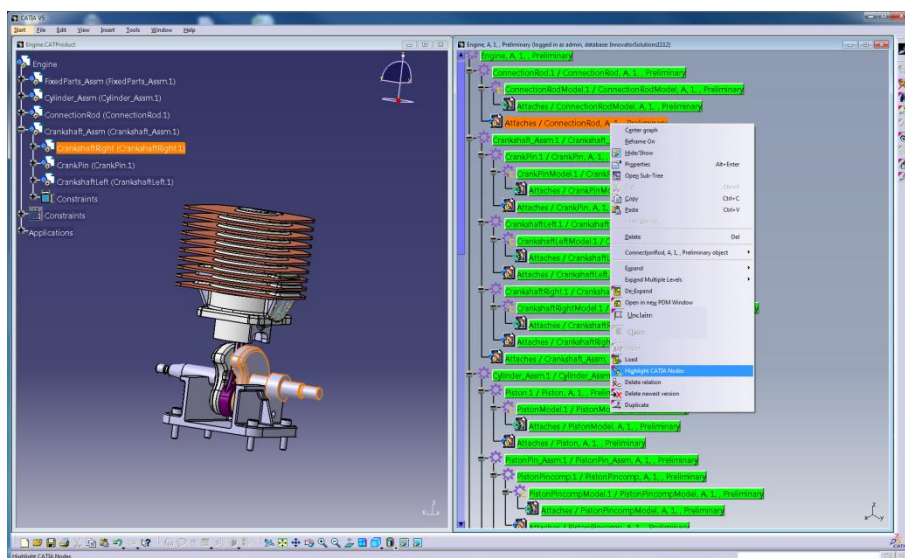

Picture 196: Action “Highlight CATIA Nodes”

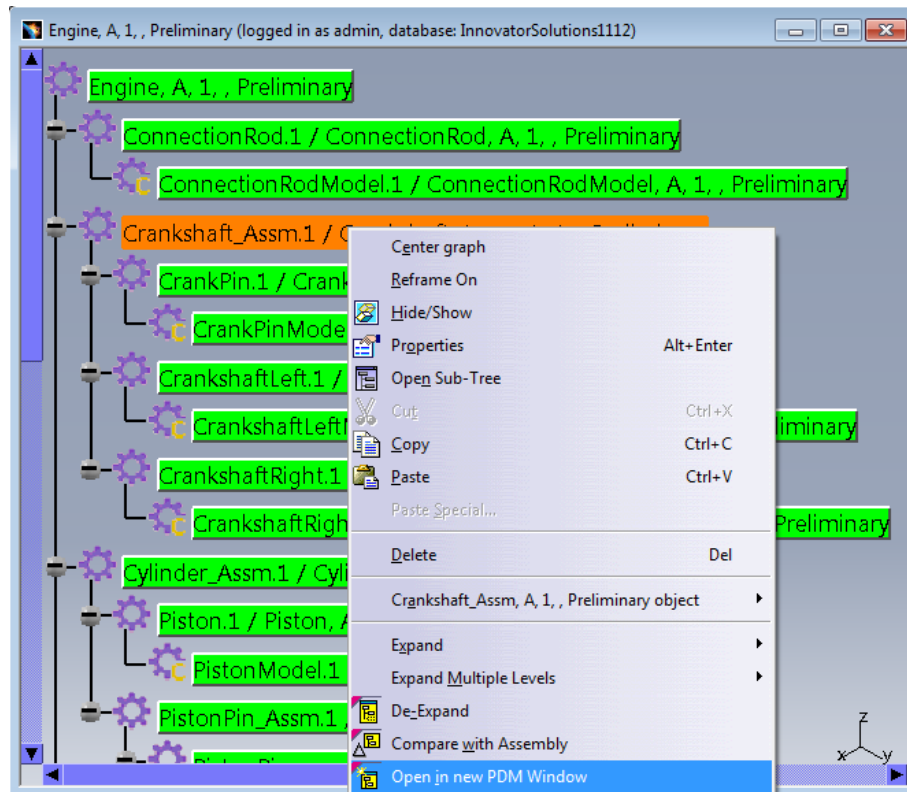

Picture 198: Action “Open in New Window”

The selected objects will be opened in a new window (see *Picture 199: Selected objects in the new window*).

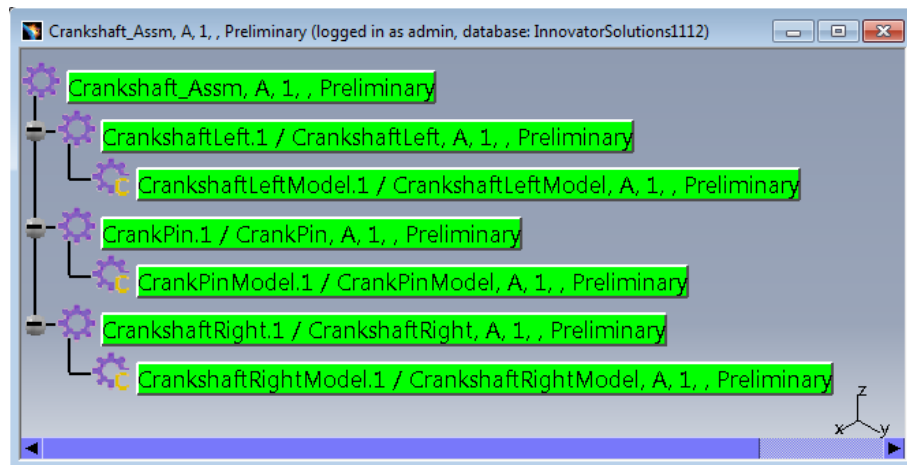

Picture 199: Selected objects in the new window

Comparing PDM Structure Trees

It is possible to compare two structures, or two generations of the same structure, displaying the differences between these two structures.

You start with two expanded structures in one or two PDM structure windows. First, you select and copy (CTRL-C) the root node of one of the structures. Then you right-click on the root node of the other structure and select the context action “Compare with Assembly”. This opens the window which displays the differences between the two structures.

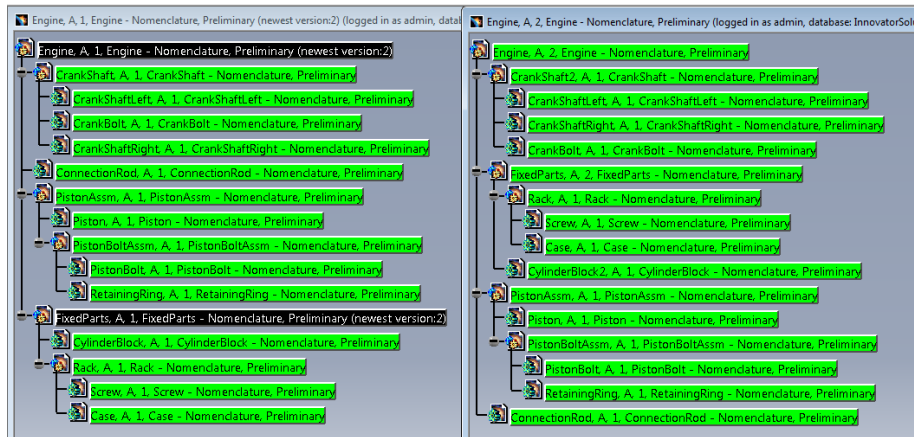

Picture 200: Two CAD Document structures to be compared

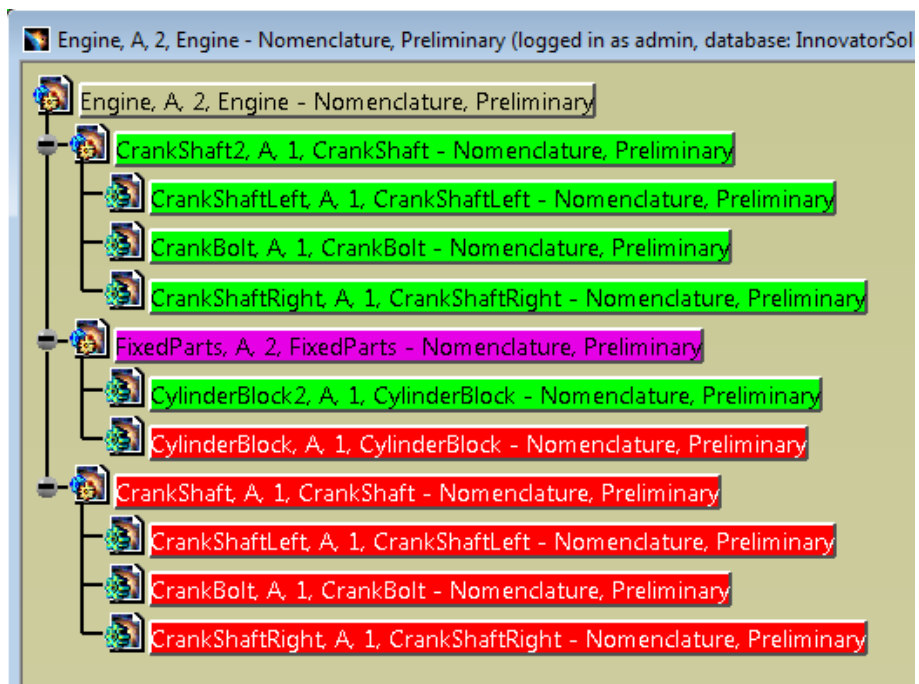

Picture 201: Window containing the differences between the two structures

Selecting Nodes in the PDM Structure Window

It is possible to select specific child nodes of a structure by defining logical AND or OR combinations of values of different attributes.

You right-click on the root node of an expanded structure and select the context action "Select Nodes". The dialog where you can enter the attribute values appears:

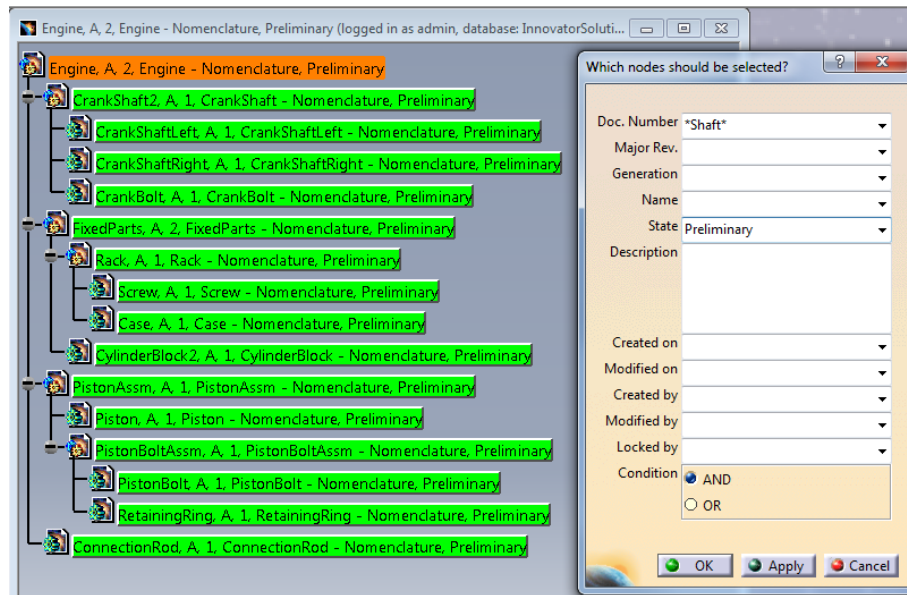

Picture 202: “Select Nodes” dialog

You can choose whether the Boolean condition with which the attribute values are combined is AND (the default) or OR.

After clicking the “OK” button the child nodes whose attribute values match the defined criteria are selected:

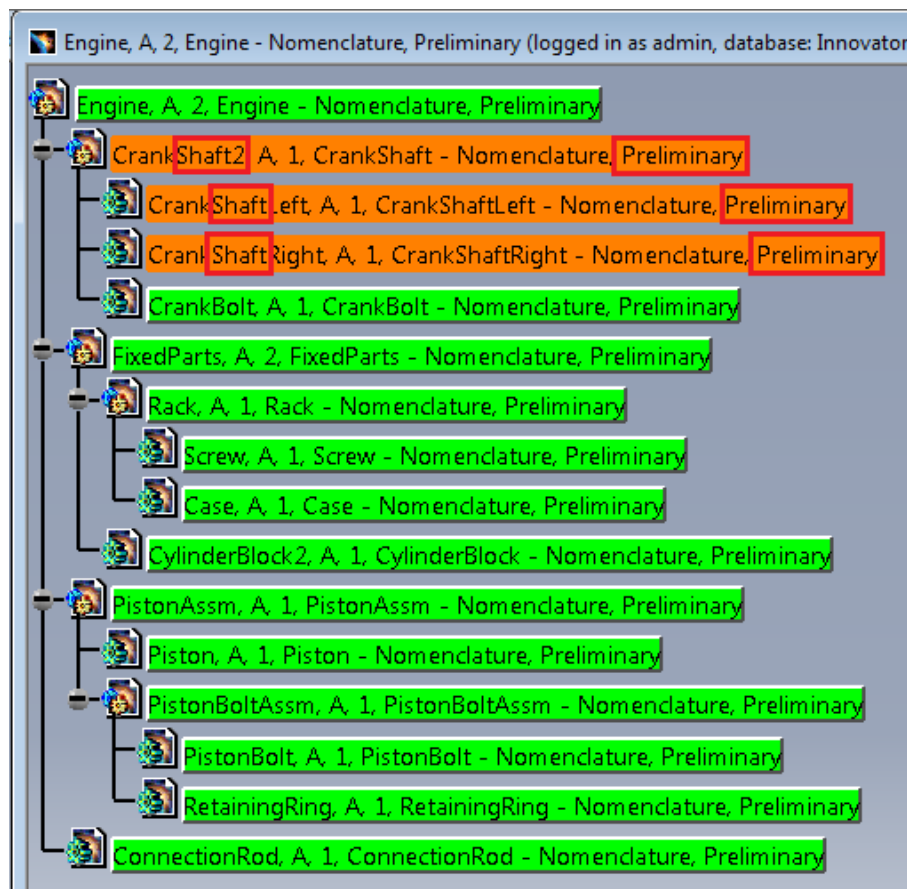

Picture 203: Selected Nodes

Force Load CATPart

When you have loaded the CATIA node into the structure via the Desk command because the file could not be loaded then you can load the CATIA data with the required PDM Workbench information. For this you have to select the CATIA node and open the context menu. Then choose *PDM Workbench* → *Force Load CATPart* (see *Picture 204: Action "Force Load CATPart"*).

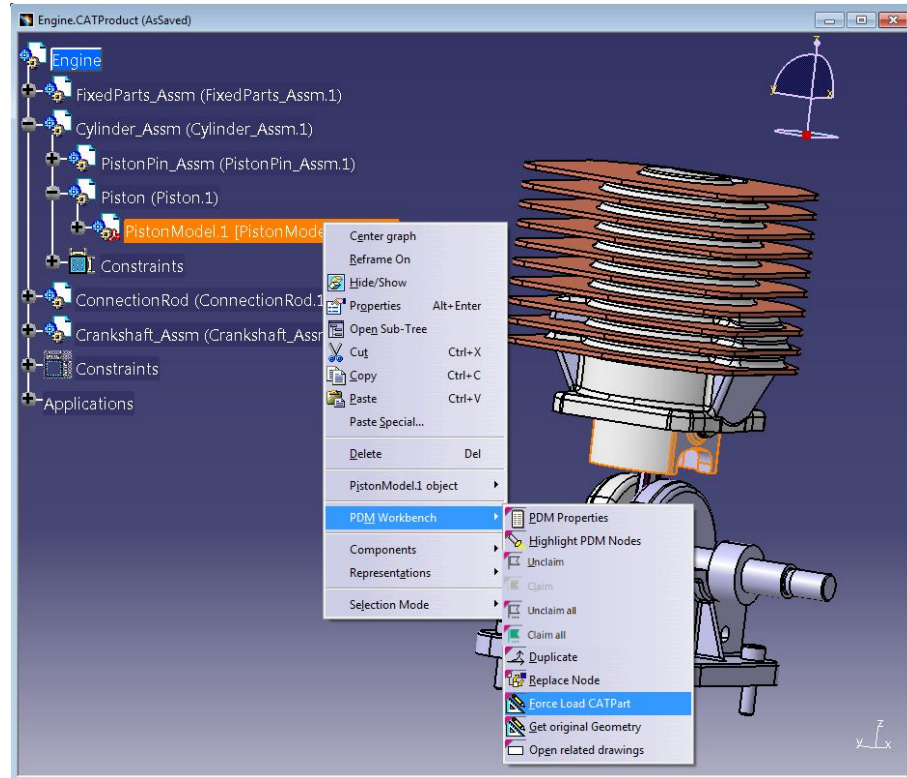

Picture 204: Action "Force Load CATPart"

Insert from PDM

The CATIA file which corresponds to an existing Aras Innovator item can be inserted directly into the CATIA structure.

You right-click on an existing CATProduct node in a CATIA Structure window and select "Insert PDM Node" (see *Picture 205: Action "Insert PDM Node"*).

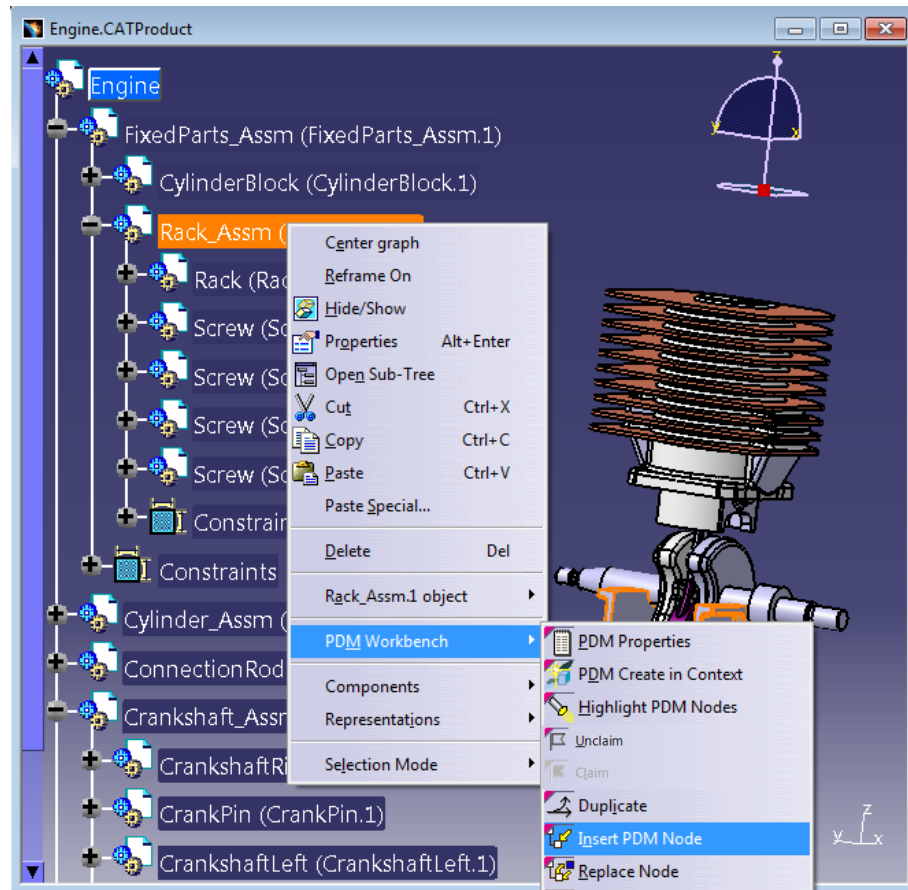

Picture 205: Action “Insert PDM Node”

A restricted “PDM Query” dialog opens. In the CAD Document Structure Data Model CATPart and CATProduct items can be queried; in the BOM Part Structure Data Model Part items can be selected (see *Picture 206: Insert PDM Node – “PDM Query” dialog type selection*).

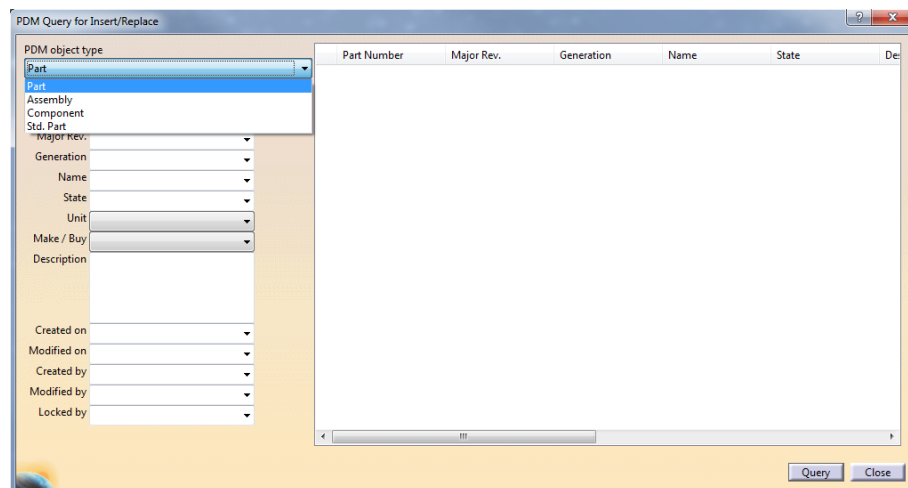

Picture 206: Insert PDM Node – “PDM Query” dialog type selection

After the query is performed all resulting items are displayed in the result list, like in the regular “PDM Query” dialog (see *Picture 207: Insert PDM Node – query result*).

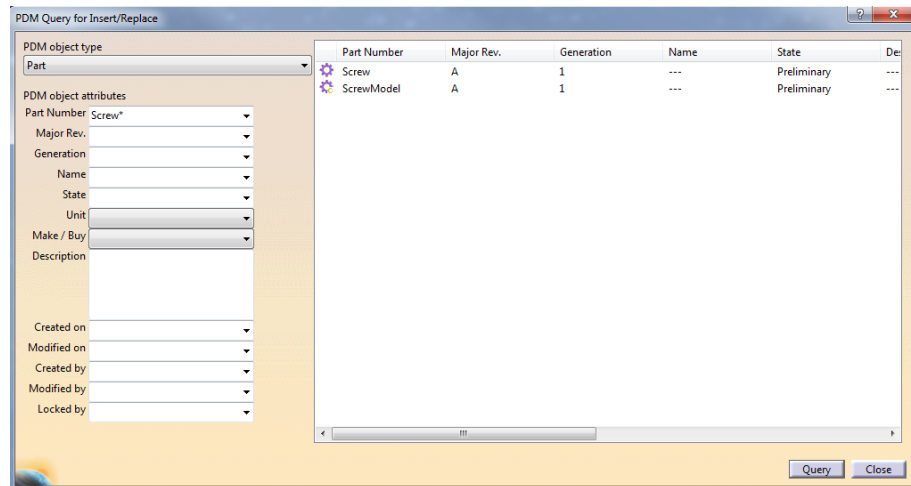

Picture 207: Insert PDM Node – query result

Double-clicking on one of the result items in the list causes its corresponding file to be downloaded and inserted into the selected CATProduct node in the CATIA structure (see *Picture 208: Item inserted in existing structure*).

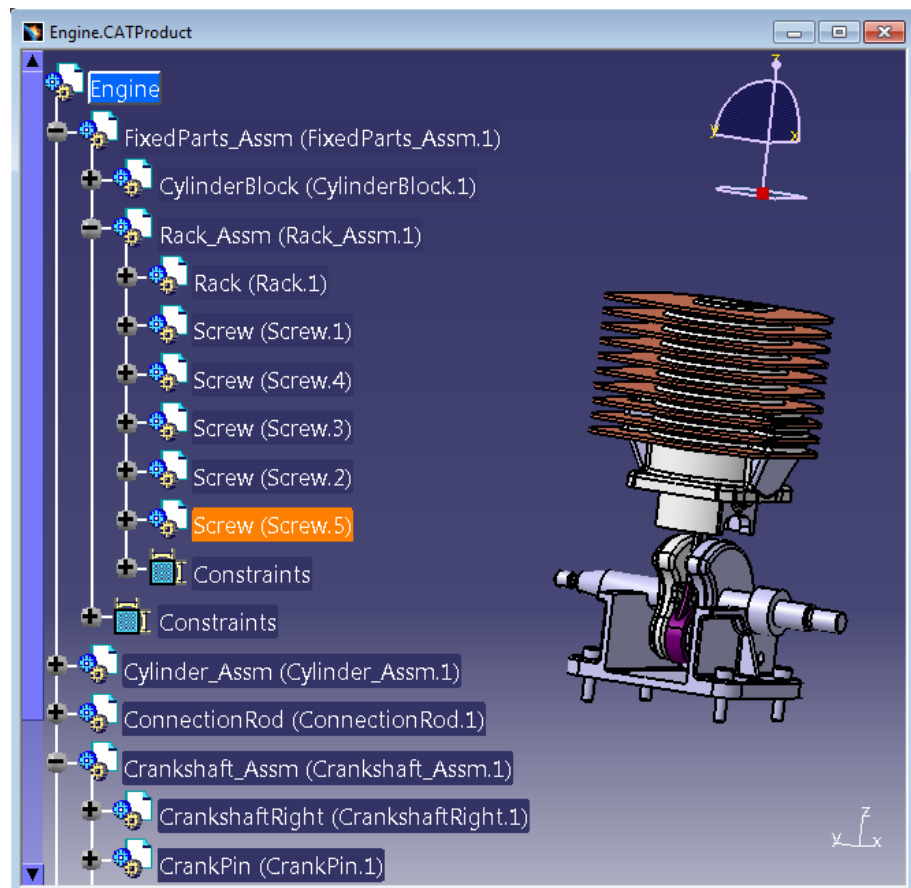

Picture 208: Item inserted in existing structure

It is possible to query for items which are already contained in the CATIA structure, as well as for items which do not exist in the structure yet.

The newly inserted CATIA node is not updated to PDM yet, the next “Update” process will create the corresponding structure relation.

Insert from Aras Innovator keep “PDM Query” Dialog

The “PDM Query” dialog stays open. The user can insert multiple items from the same “PDM Query” dialog.

Replace from PDM

The node selected in the CATIA structure can be replaced by the CATIA file which corresponds to an existing Aras Innovator item.

Warning: This functionality can create broken links in the CATIA structure.

In order for CATIA links to be preserved, the link conditions of the replaced geometry and the replacing geometry has to be compatible.

If the new CATIA document is not compatible with the link conditions of the PDM structure the “CATIA V5 Replace” functionality presents a warning dialog.

This is the “Impacts on Replace” dialog as presented by the standard “CATIA V5 Replace” functionality (see *Picture 209: “Impacts on Replace” standard CATIA dialog*).

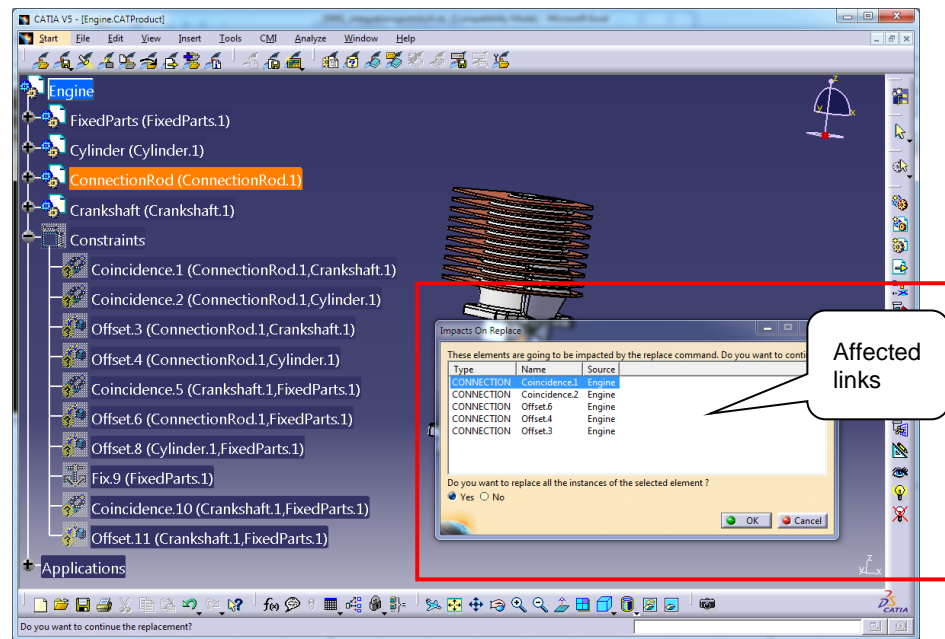

Picture 209: “Impacts on Replace” standard CATIA dialog

This “Impacts on Replace” dialog cannot be implemented by T-Systems due to lack of sufficient APIs.

If the inserted CATIA document is not compatible linkage information in the product structure gets lost. In this case some constraints are broken (see *Picture 210: Constraints destroyed by “Replace” operation*).

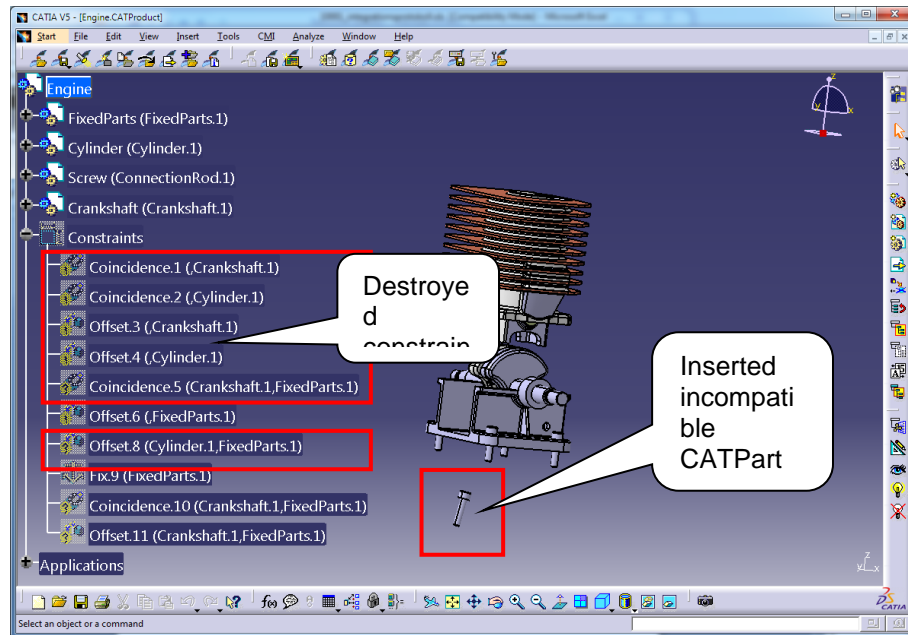

Picture 210: Constraints destroyed by “Replace” operation

This possibility of breaking CATIA links needs to be taken into account when this functionality is used. If in doubt, please load the geometry which is supposed to replace existing geometry in the structure with “Load” and use the regular CATIA replace operation.

The functionality is used as follows:

You right-click on an existing CATProduct or CATPart node in a CATIA structure window and select “Replace Node” (see *Picture 211: Action “Replace Node”*).

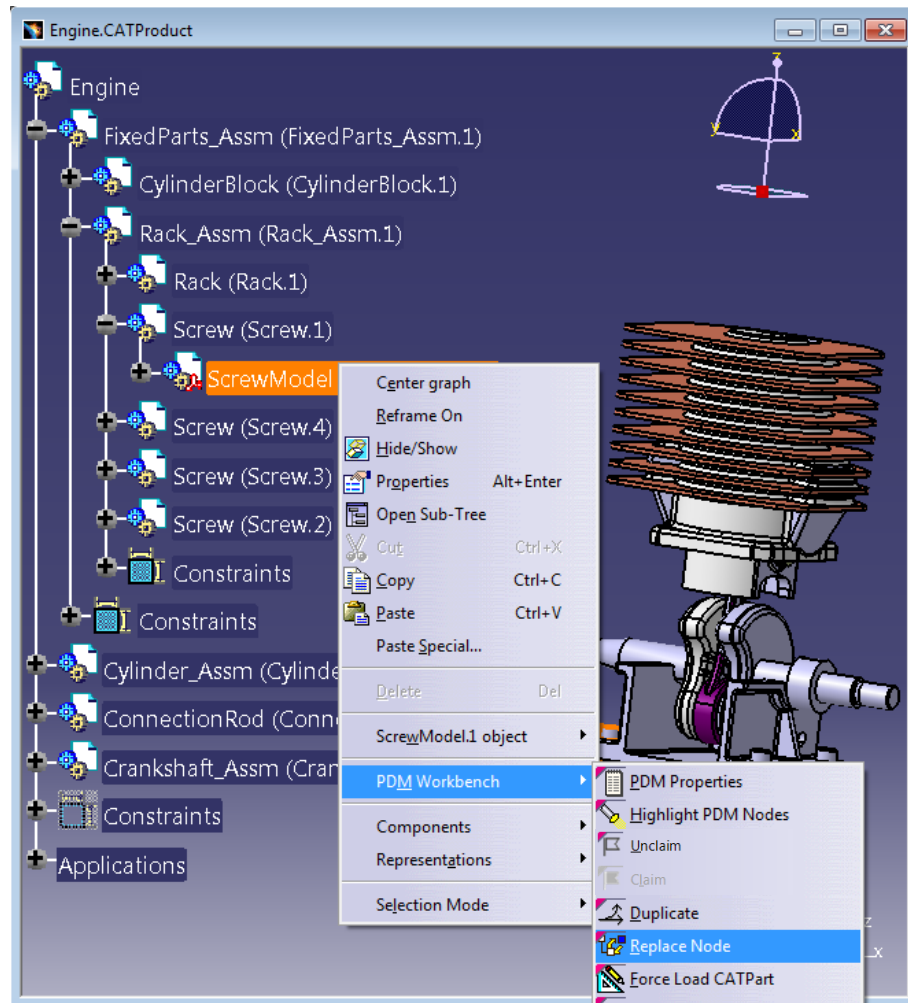

Picture 211: Action “Replace Node”

As in the “Insert PDM Node” case, a restricted query window opens. You can query for existing items and double-click on one of the found items to select the one which should replace the selected CATIA structure node (see *Picture 212: Select replacing Node*).

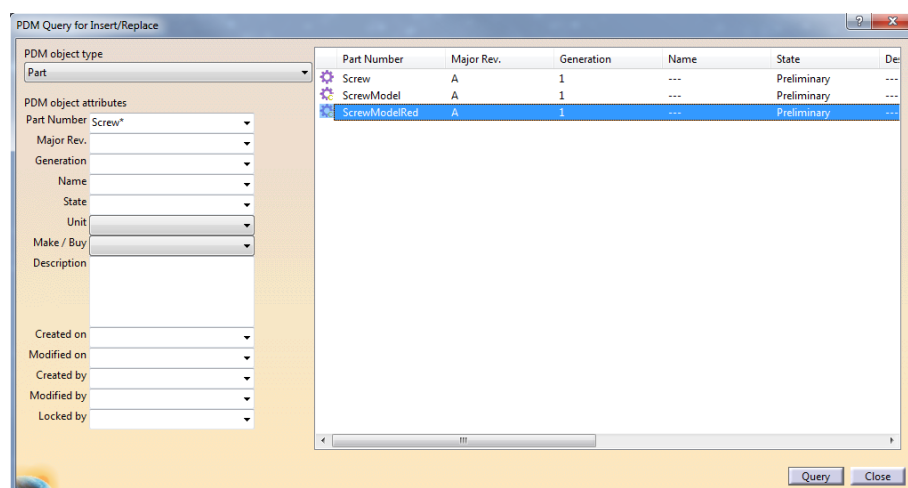

Picture 212: Select replacing Node

Then you get to decide whether only the selected node or all instances of the document should be replaced (see *Picture 213: “Replace all instances” prompt*).

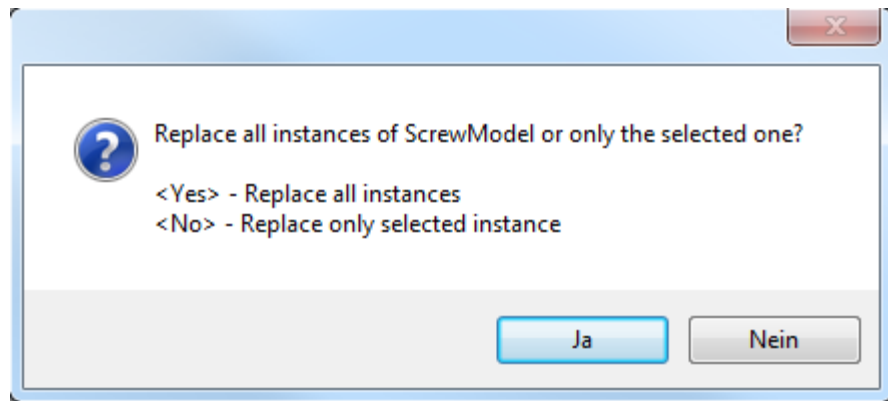

Picture 213: "Replace all instances" prompt

After that the selected instance or all of the instances of the selected CATIA node will be replaced by the CATIA file related to the queried and selected PDM item.

It is not possible to replace CATIA documents in a CATIA session when the new file has the same File Name as the file to be replaced, because both files would be located in the same directory (PDM Workbench exchange directory).

Replacing CATIA nodes does not change the instance names of the replaced nodes. Only nodes in the structure in the active window are affected by the replace operation.

Synchronize CAD Structure to BOM

It is possible to perform a synchronization of the CAD structure information to the corresponding Part BOM structure if every CAD Document in the structure has a corresponding Part item (see *Automatic Part Creation in CAD Document Structure Data Model*).

You click on the "Synchronize to BOM" context menu on the CATProduct document (see *Picture 214: Action "Synchronize to BOM"*).

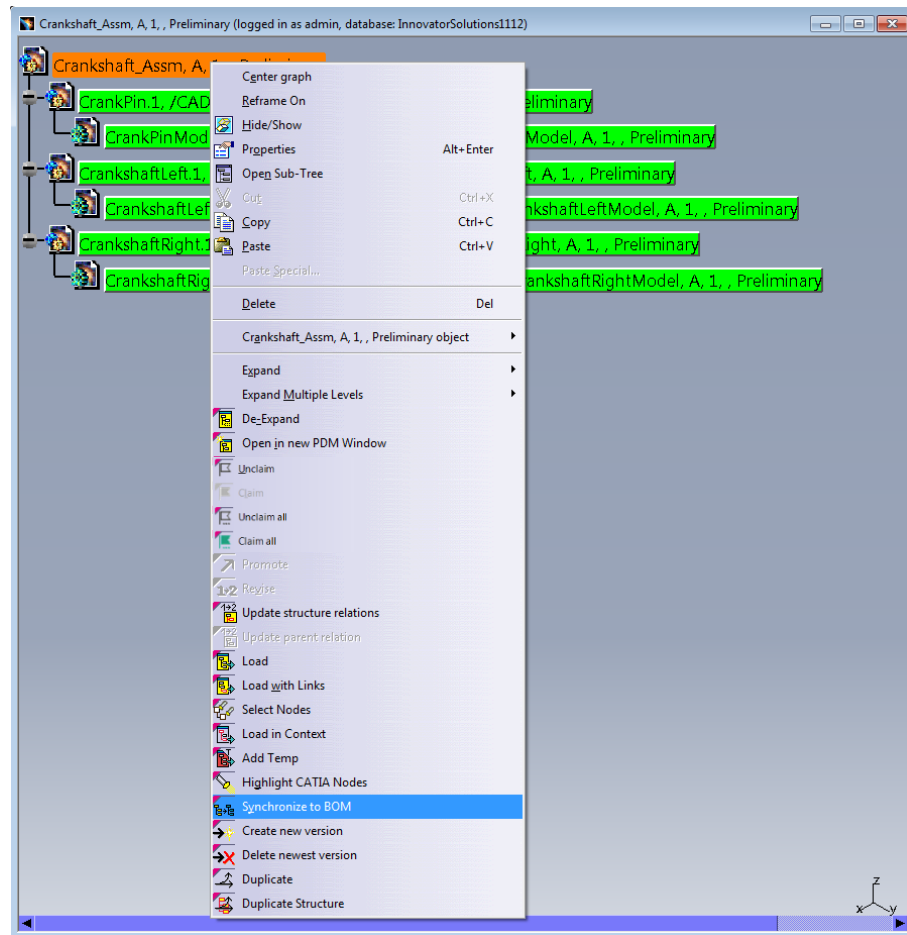

Picture 214: Action “Synchronize to BOM”

You have to confirm the synchronization to BOM (see *Picture 215: Action “Synchronize to BOM” – Confirmation*).

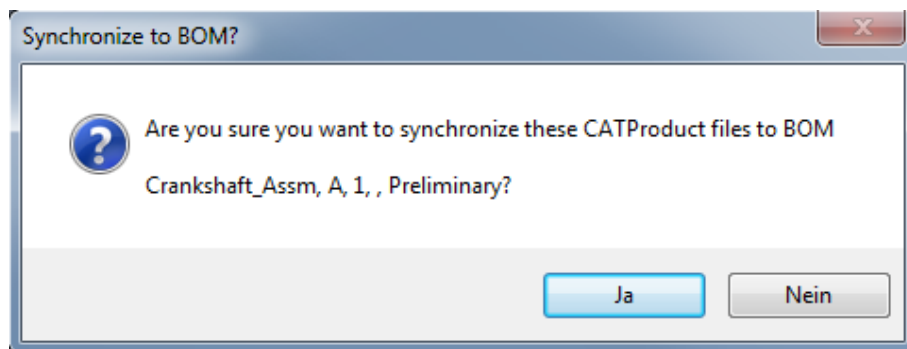

Picture 215: Action “Synchronize to BOM” – Confirmation

If all CAD Documents in the structure are related to a part, and if all the parts are claimed by you, then the CAD structure instance information (instance name, instance description, and transformation matrix) is applied to the PDM structure.

The resulting structure can be expanded in the PDM Structure window (see *Picture 216: Created or updated PDM structure*).

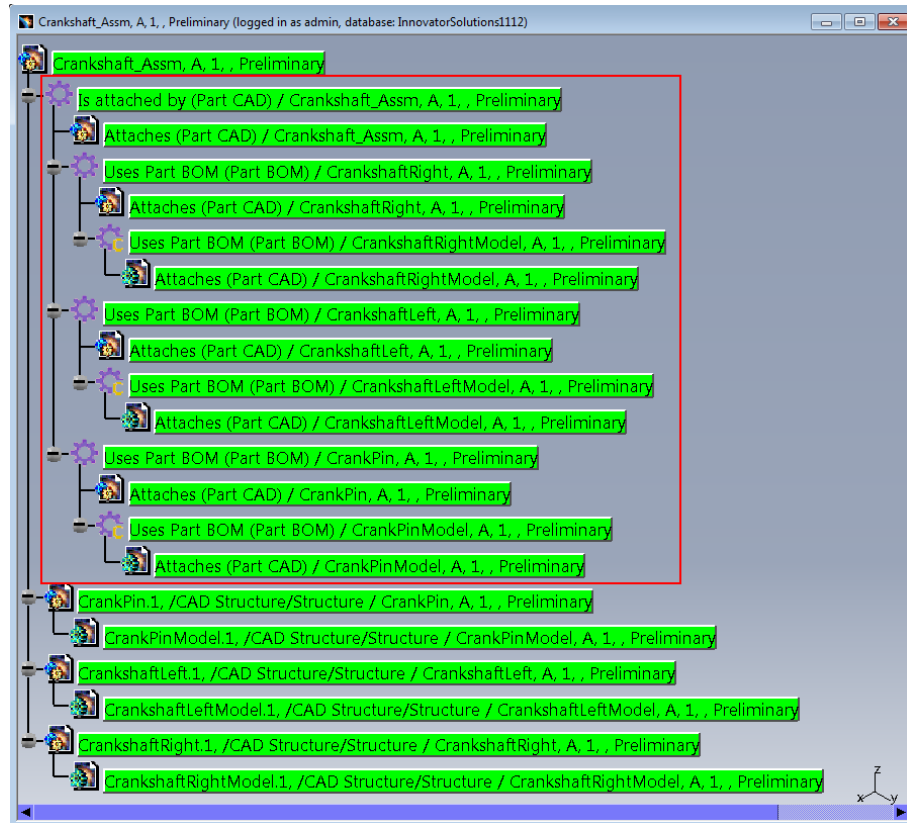

Picture 216: Created or updated PDM structure

This functionality is also available in the Aras Innovator web client, too:

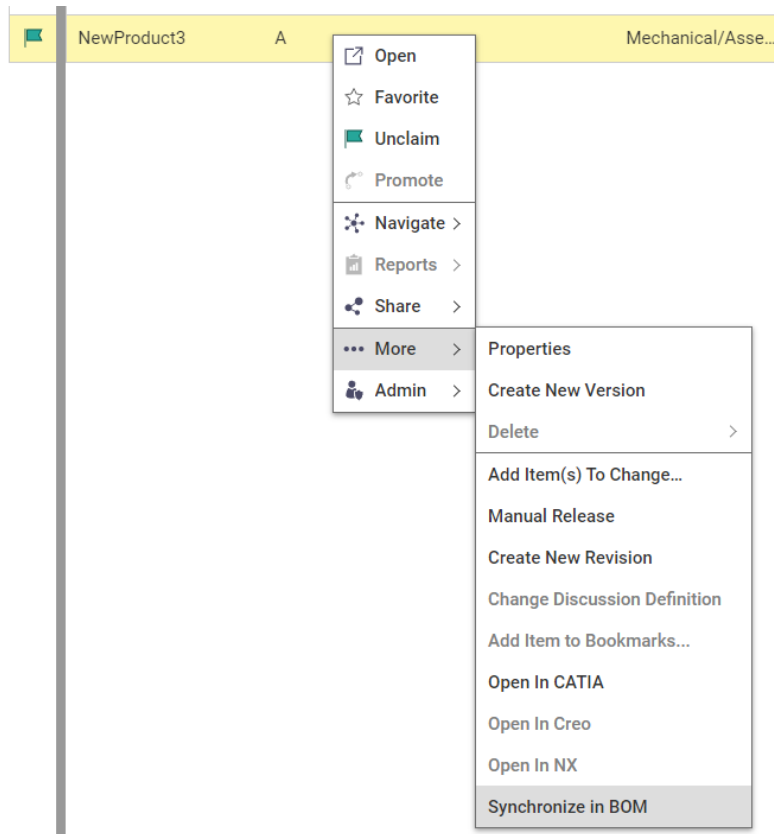

Picture 217: "Synchronize in BOM" in Aras Innovator web client

Attribute Mapping

CATPart and CATProduct

CATIA standard and user-defined properties can be mapped to PDM attributes.

In the following example the standard CATIA attributes “Nomenclature” and “Description” are mapped to the attributes “name” and “description” of the Aras Innovator part object (see *Picture 218: Part mapping – Standard attributes in the “Properties” dialog* and *Picture 219: Part mapping – Configuration of standard attributes in Aras Innovator*).

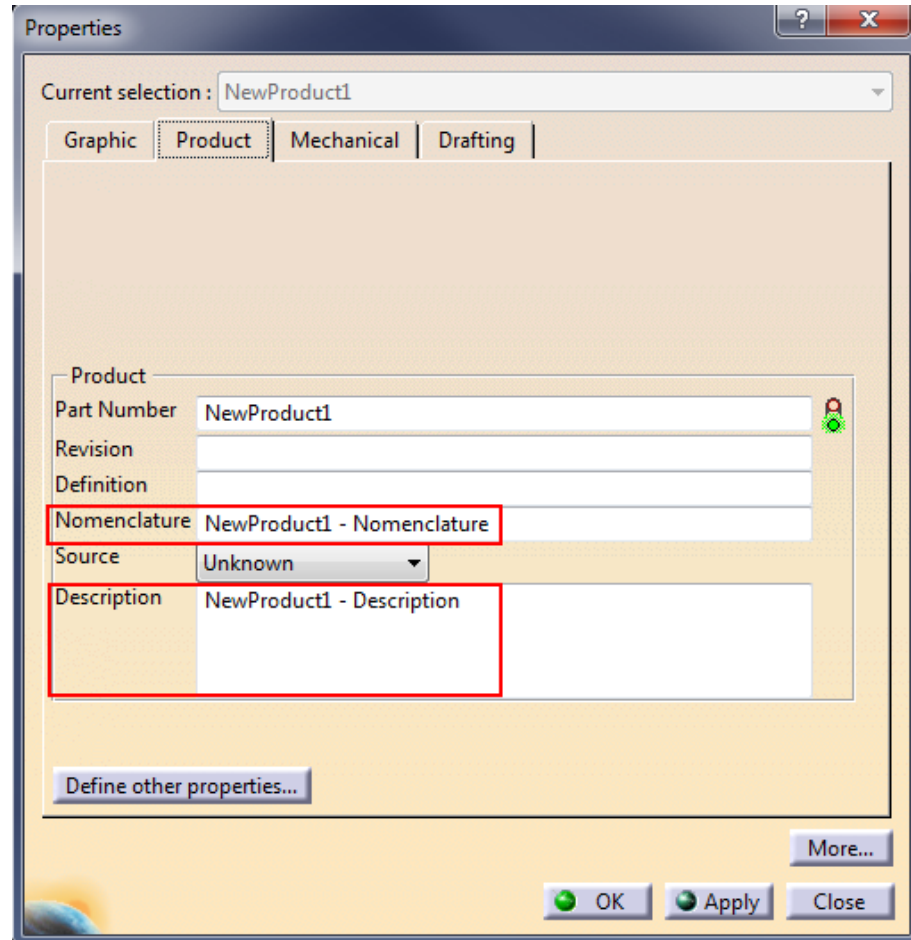

Picture 218: Part mapping – Standard attributes in the “Properties” dialog

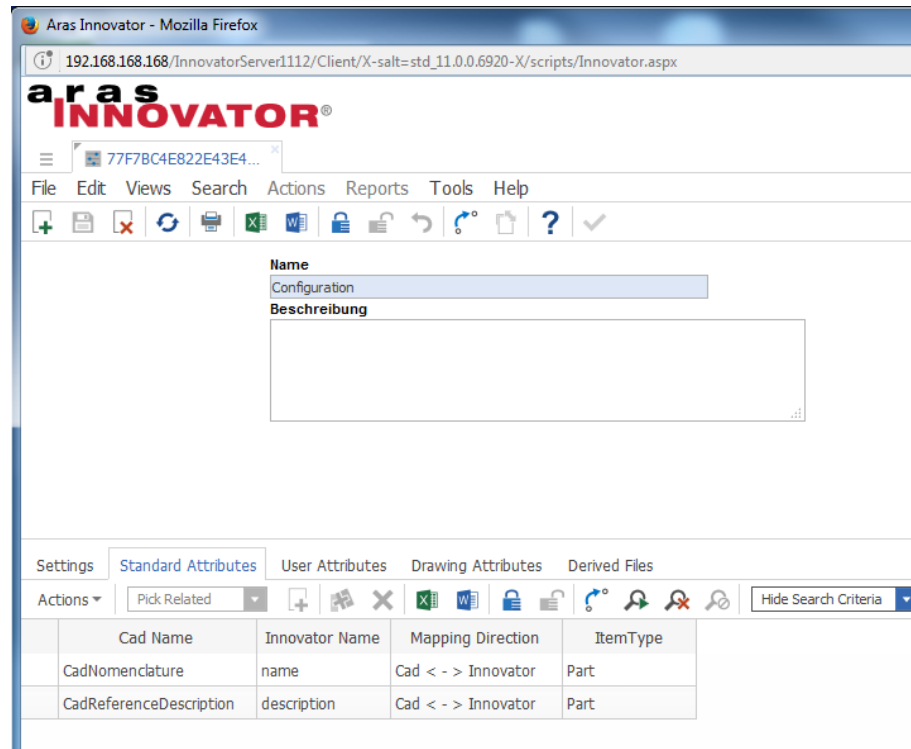

Picture 219: Part mapping – Configuration of standard attributes in Aras Innovator

In the “PDM Create” dialog the attributes are pre-filled (see *Picture 220: Part mapping – Pre-filled “PDM Create” dialog*).

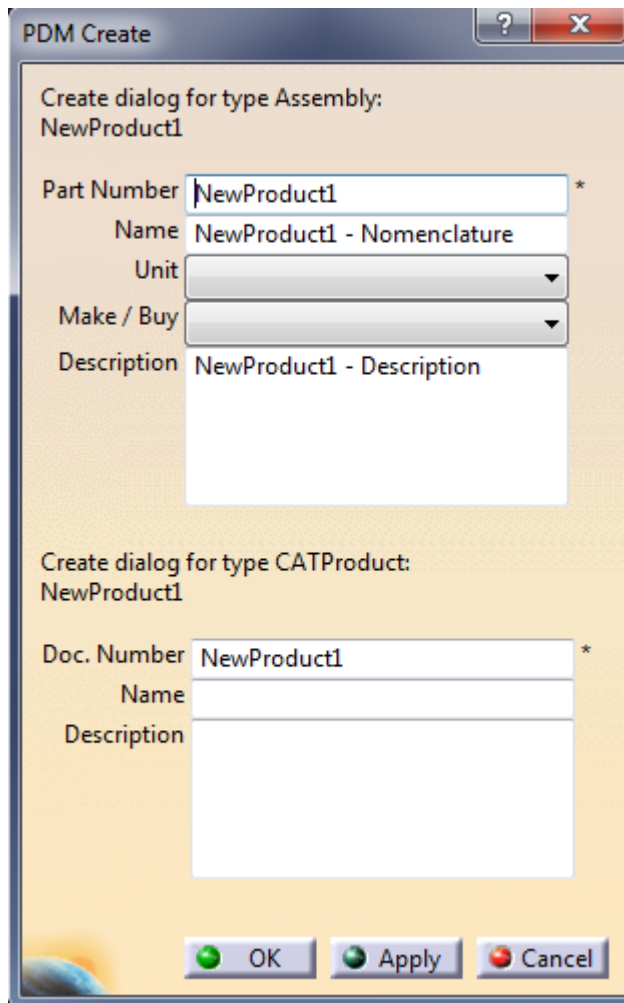

Picture 220: Part mapping – Pre-filled “PDM Create” dialog

After creating the part with Update the defined CATIA attribute values have been written to the PDM part object (see *Picture 221: Part mapping – Standard attributes in the “Properties” dialog of the PDM node* and *Picture 222: Part mapping – Standard attributes in Aras Innovator*).

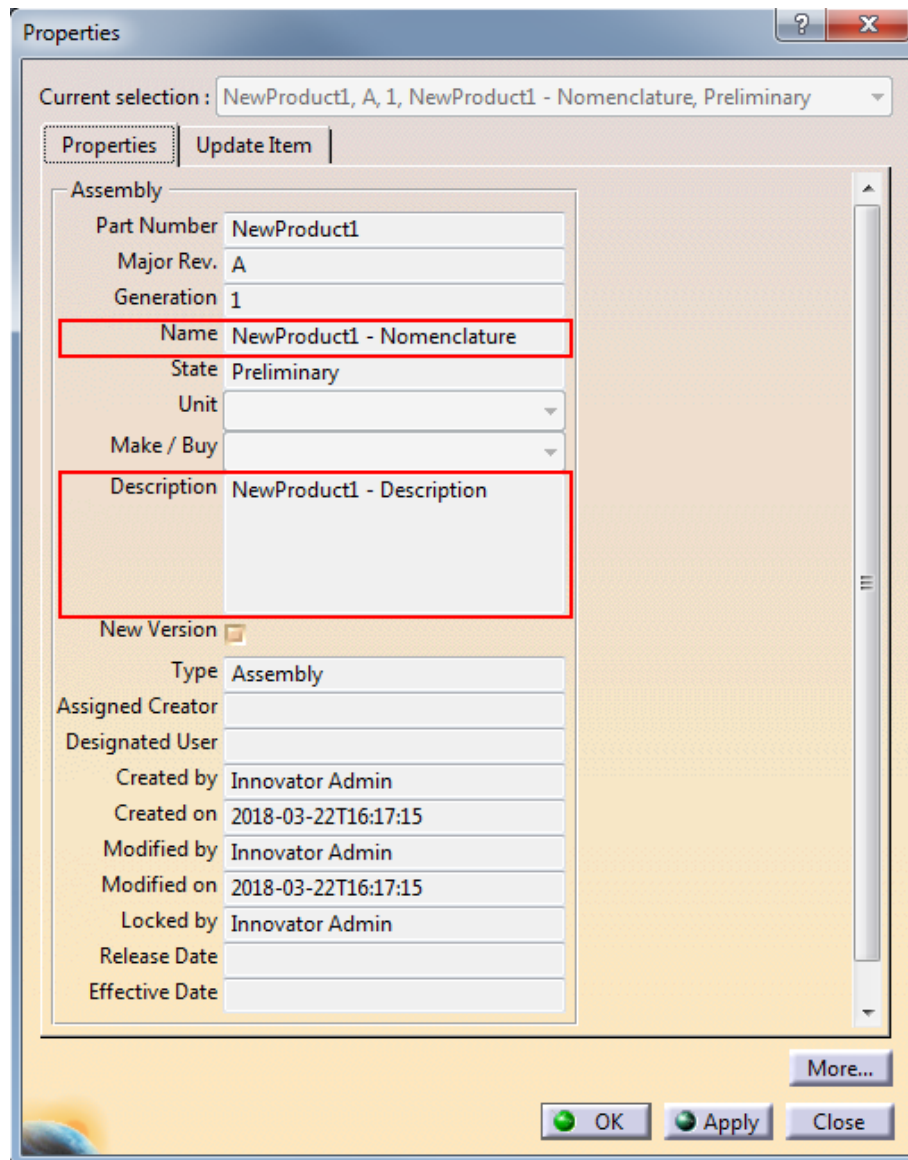

Picture 221: Part mapping – Standard attributes in the “Properties” dialog of the PDM node

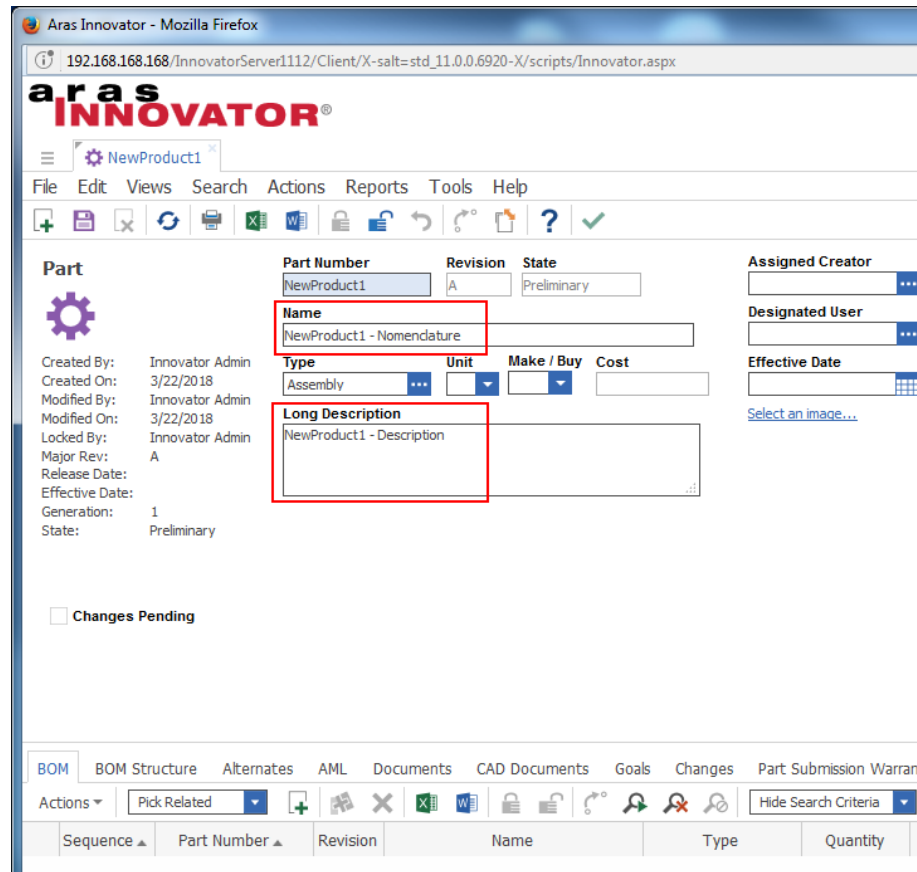

Picture 222: Part mapping – Standard attributes in Aras Innovator

In the next example the standard CATIA attributes “Nomenclature” and “Description” are mapped to the attributes “name” and “description” of the Aras Innovator document object (see *Picture 223: CAD Document mapping – Standard attributes in the “Properties” dialog* and *Picture 224: CAD Document mapping – Configuration of standard attributes in Aras Innovator*)

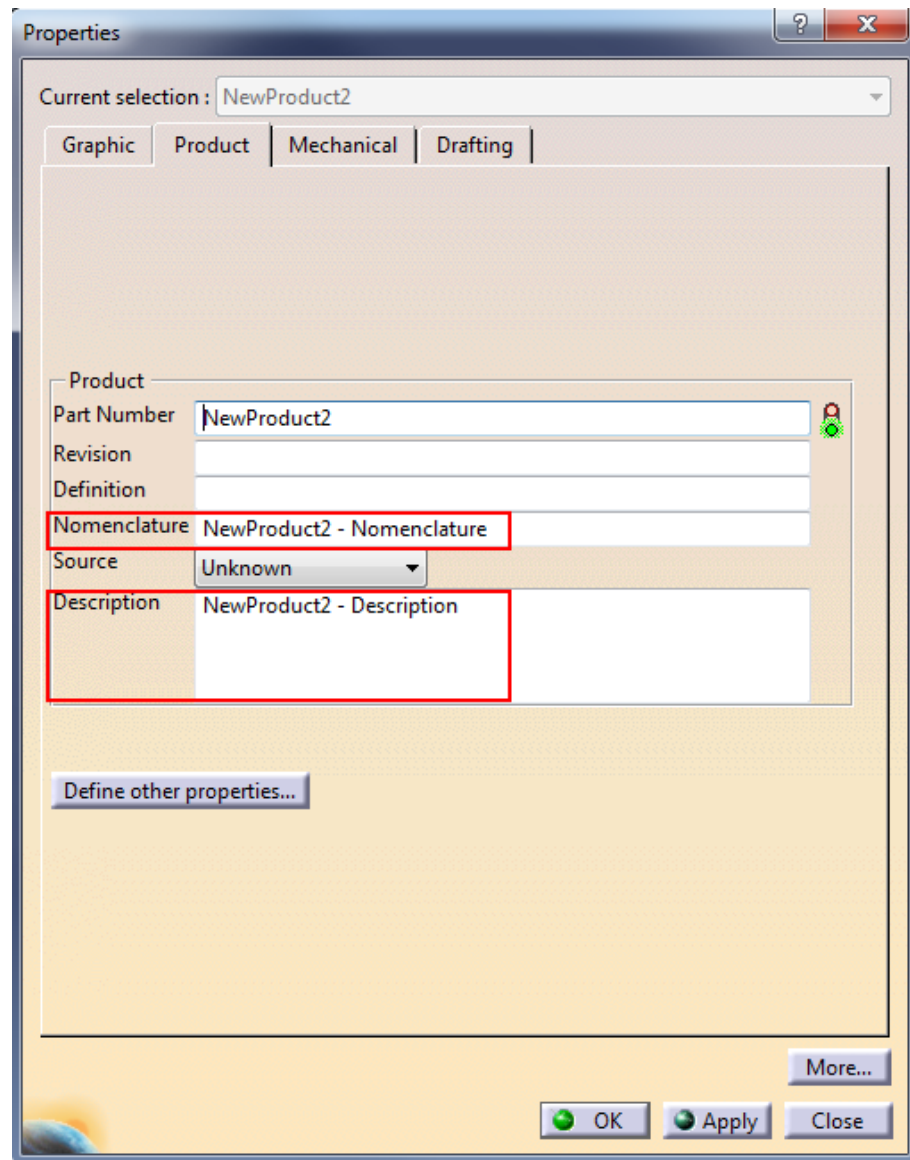

Picture 223: CAD Document mapping – Standard attributes in the “Properties” dialog

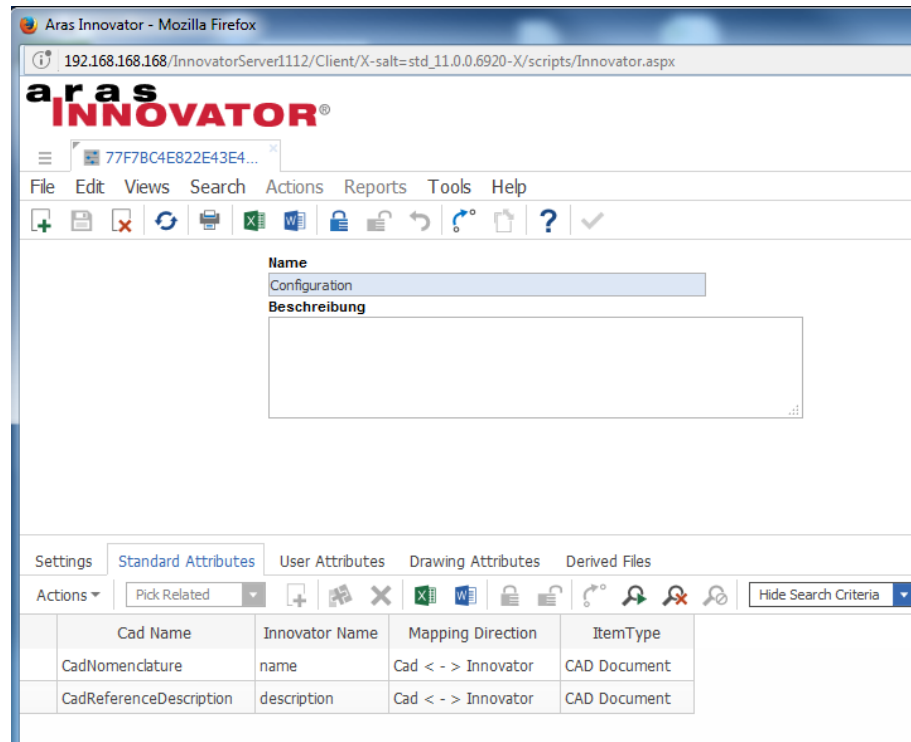

Picture 224: CAD Document mapping – Configuration of standard attributes in Aras Innovator

In the “PDM Create” dialog the attributes are pre-filled (see *Picture 225: CAD Document mapping – Pre-filled “PDM Create” dialog*).

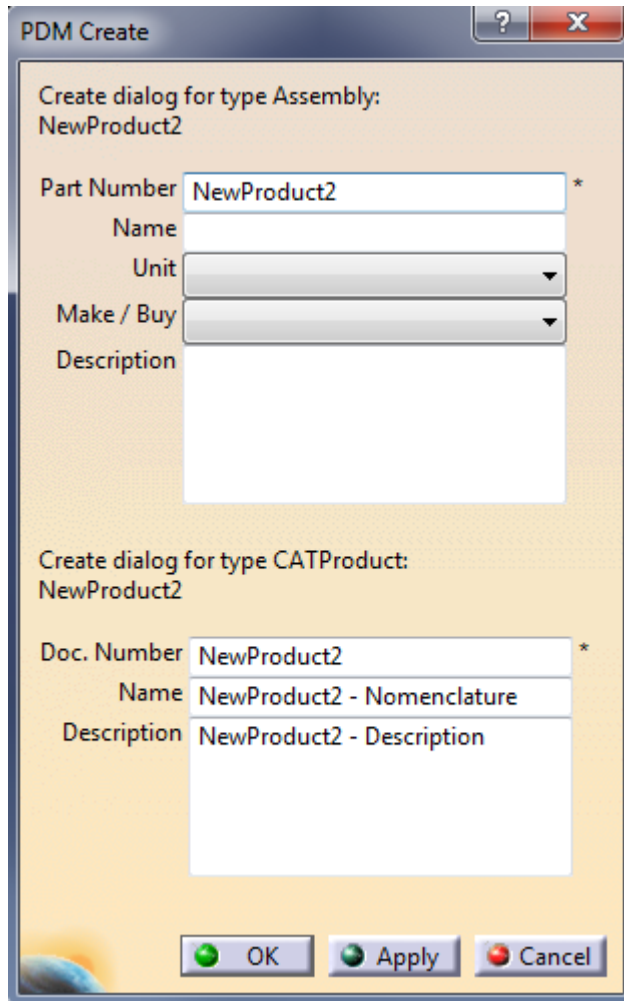

Picture 225: CAD Document mapping – Pre-filled “PDM Create” dialog

After creating the part with Update the defined CATIA attribute values have been written to the CAD Document item (see *Picture 226: CAD Document mapping – Standard attributes in the “Properties” dialog of the PDM node* and *Picture 227: CAD Document mapping – Standard attributes in Aras Innovator*)

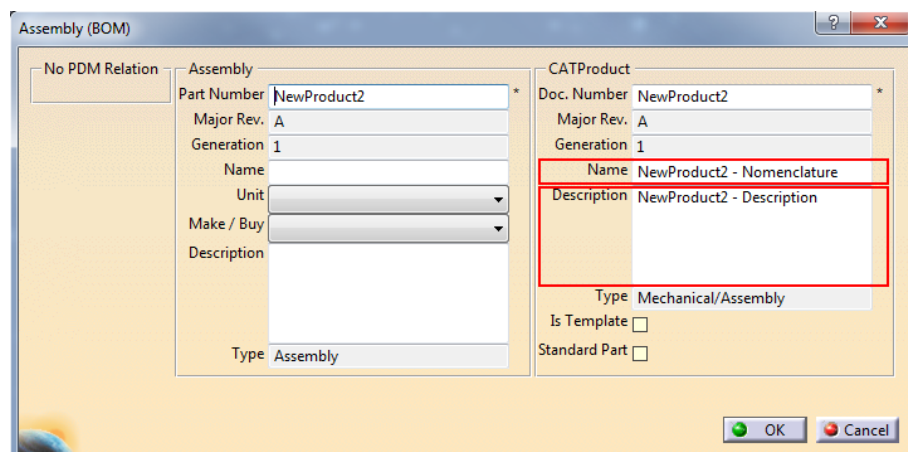

Picture 226: CAD Document mapping – Standard attributes in the “Properties” dialog of the PDM node

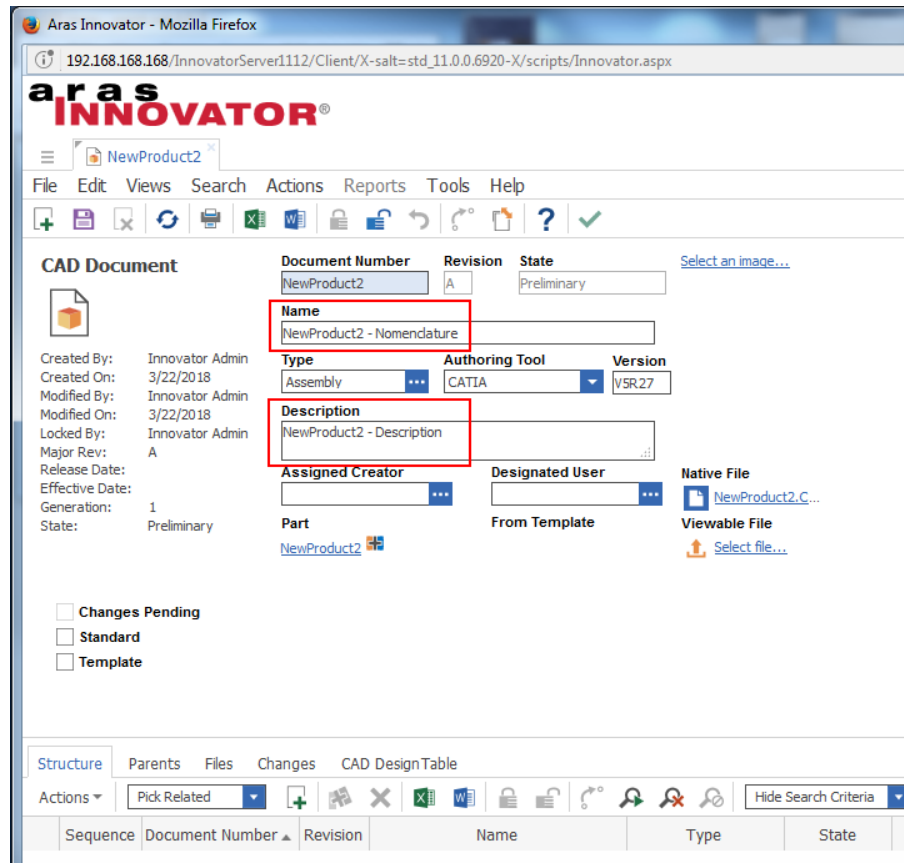

Picture 227: CAD Document mapping – Standard attributes in Aras Innovator

User-defined CATIA properties can also be mapped (see *Picture 228: Configuration of user-defined attributes in Aras Innovator*).

The standard attribute mapping is defined additionally (see *Picture 224: CAD Document mapping – Configuration of standard attributes in Aras Innovator*).

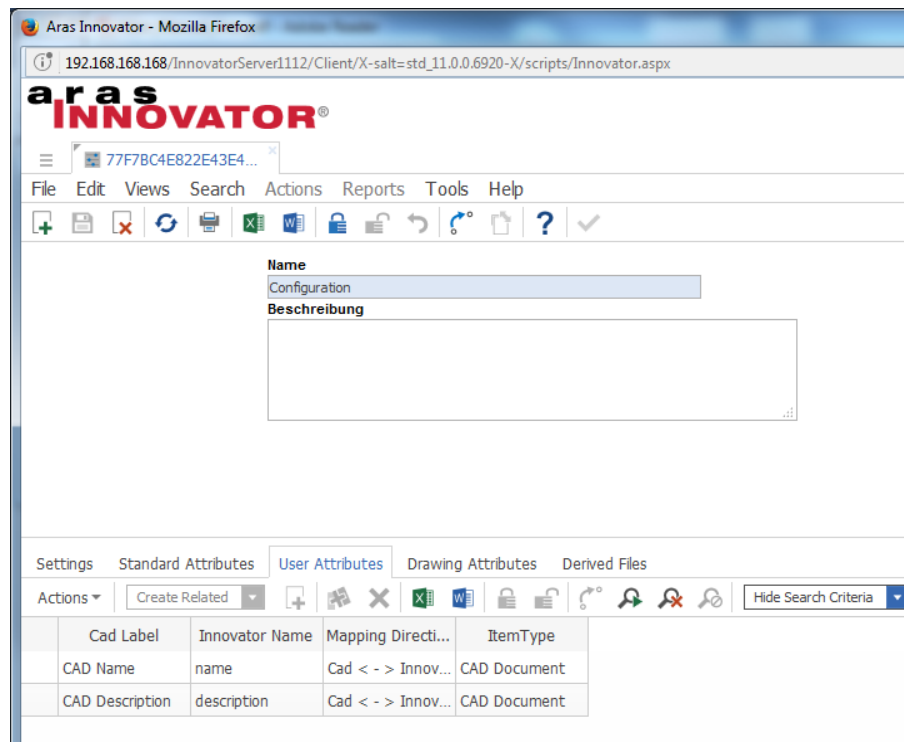

Picture 228: Configuration of user-defined attributes in Aras Innovator

While the structure is imported the values are written to the defined attributes of the Aras Innovator CAD Document item (see *Picture 231: User-defined attributes mapping – Standard Attributes in the “Properties” dialog of the PDM node* and *Picture 232: User-defined attributes mapping – Standard attributes in Aras Innovator*).

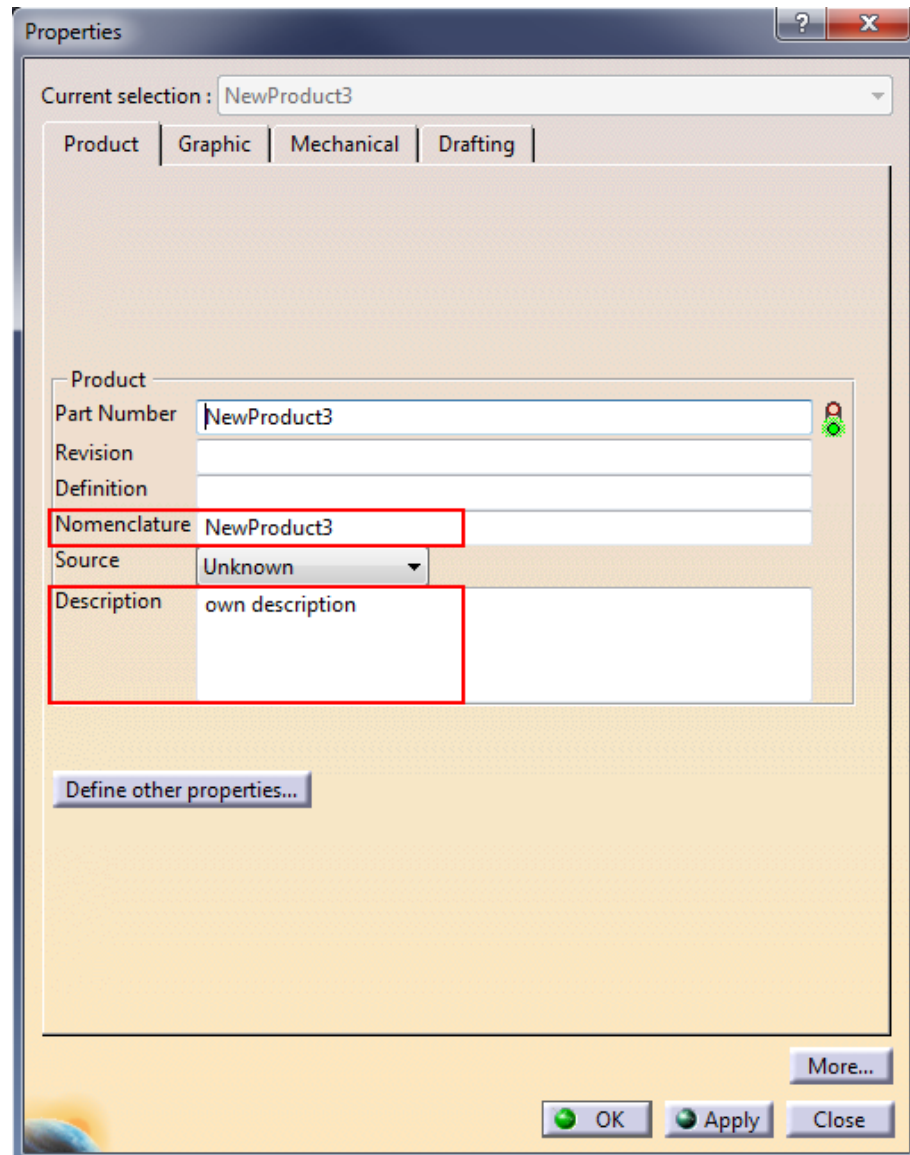

Picture 229: User-defined attributes mapping – Standard attributes in the “Properties” dialog

In the “PDM Create” dialog the attributes for the CAD Document are pre-filled (see *Picture 230: User-defined attributes mapping – Pre-filled “PDM Create” dialog*).

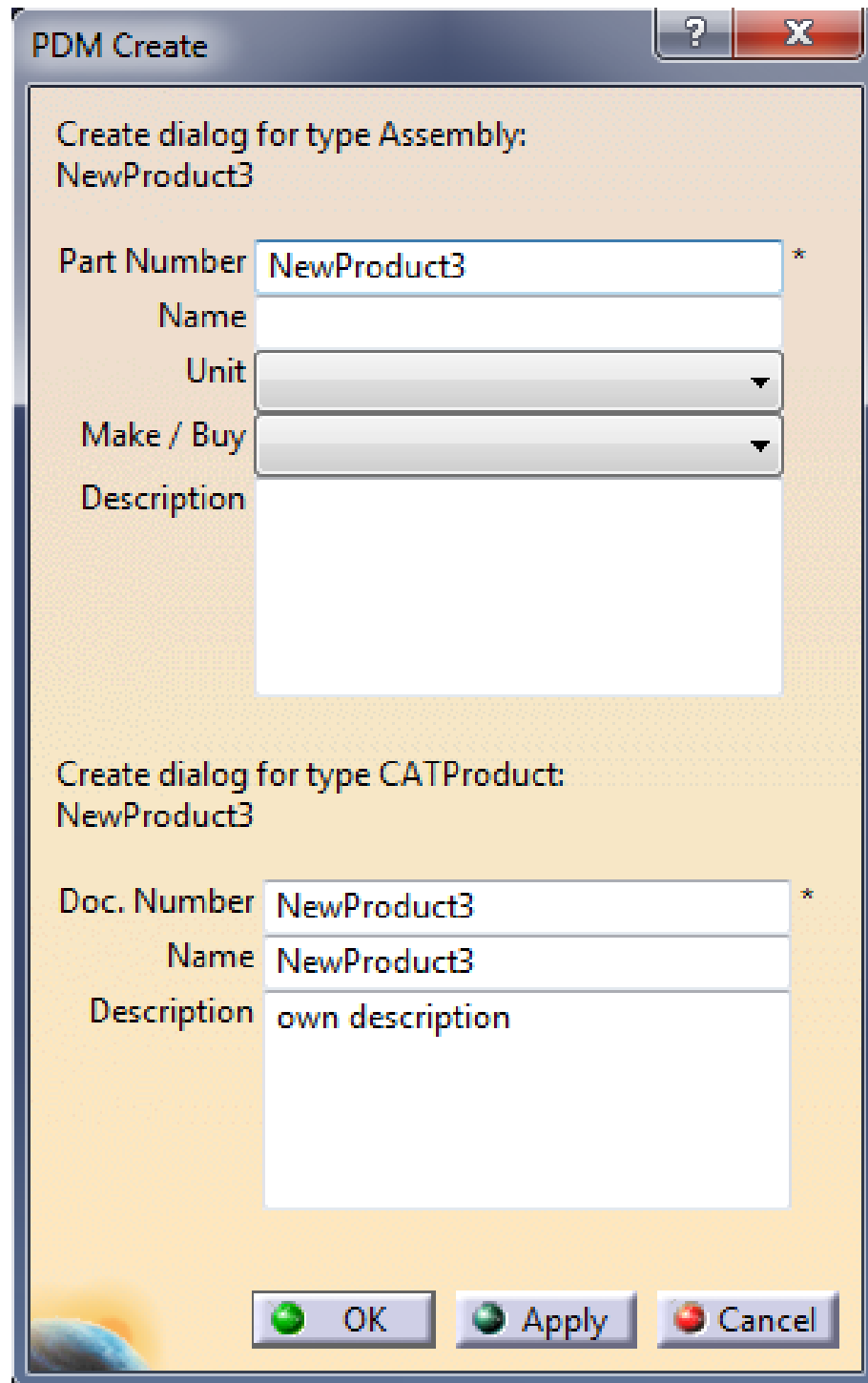

Picture 230: User-defined attributes mapping – Pre-filled “PDM Create” dialog

After creating the Part with Update the defined CATIA attribute values have been written to the CAD Document item (see *Picture 231: User-defined attributes mapping – Standard Attributes in the “Properties” dialog of the PDM node* and *Picture 232: User-defined attributes mapping – Standard attributes in Aras Innovator*).

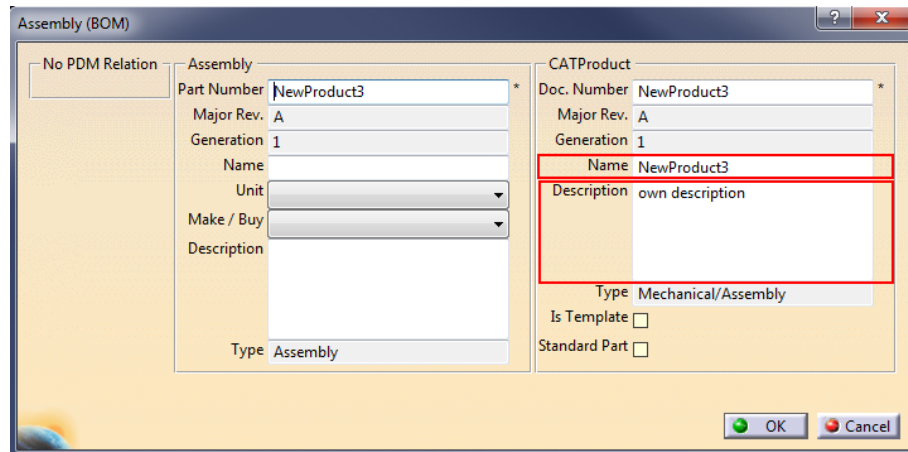

Picture 231: User-defined attributes mapping – Standard Attributes in the “Properties” dialog of the PDM node

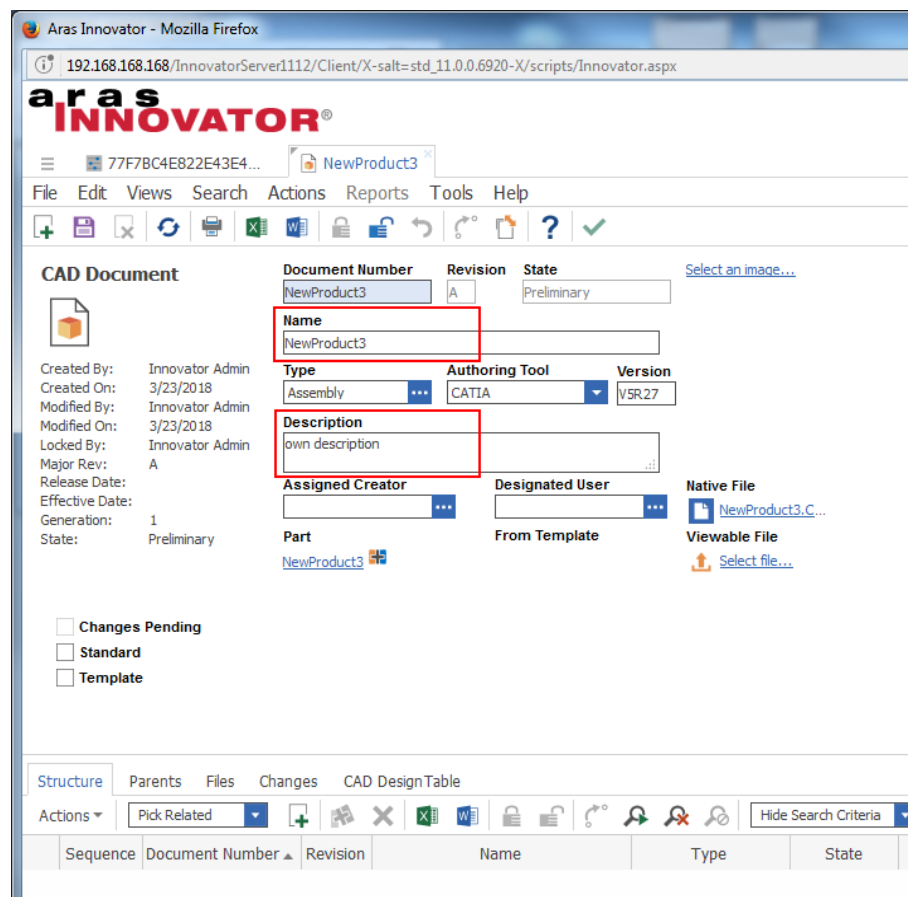

Picture 232: User-defined attributes mapping – Standard attributes in Aras Innovator

After the import or after loading the structure it can be shown that the values are written from the PDM attributes into the CATIA files (see *Picture 233: User-defined attributes in the “Properties” dialog*).

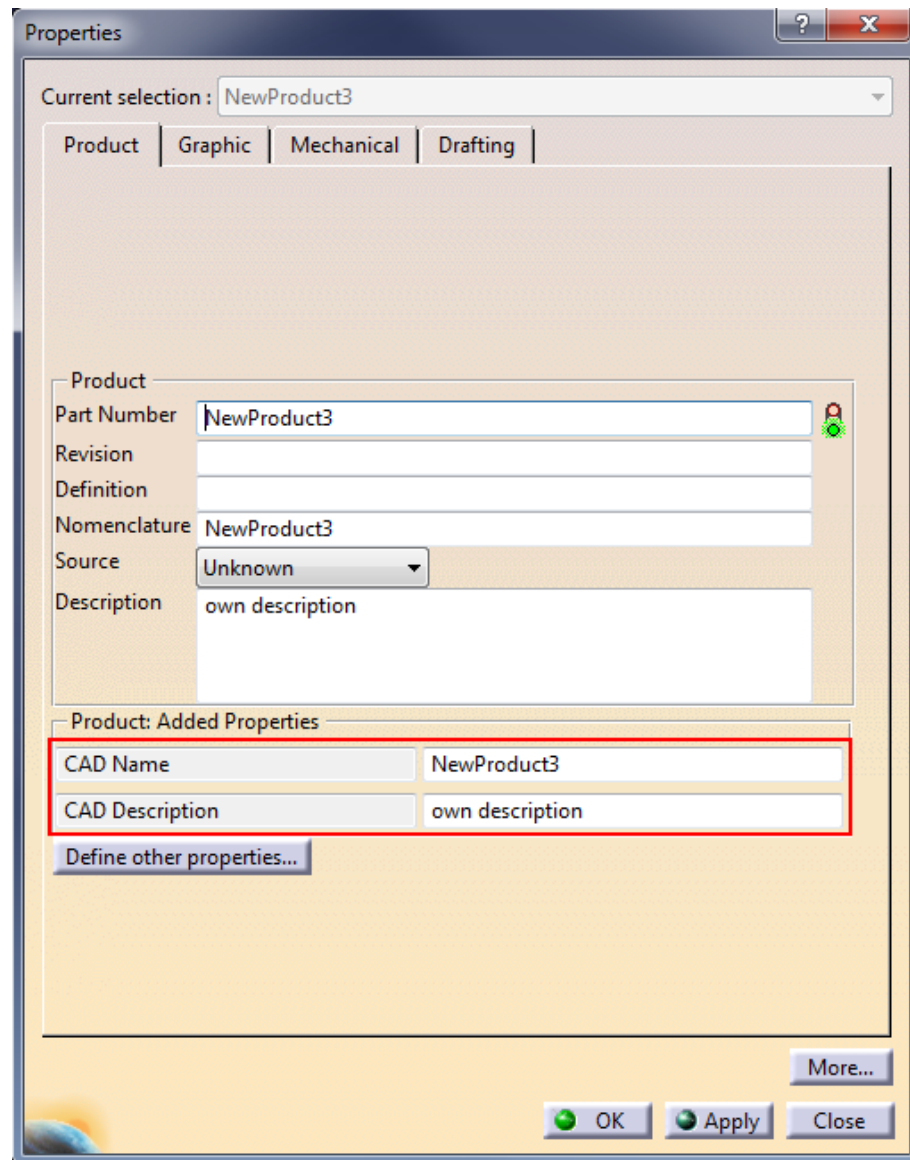

Picture 233: User-defined attributes in the “Properties” dialog.

Because of the mapping direction of the properties it is also possible to change the values in the CATIA properties. After the update of the structure the values are written from the CATIA files into the PDM attributes.

CATDrawing

PDM attribute values of the drawing CAD Document item can be mapped to CATDrawing attributes (see *Picture 234: Drawing attributes mapping – Configuration of Drawing attributes in Aras Innovator*).

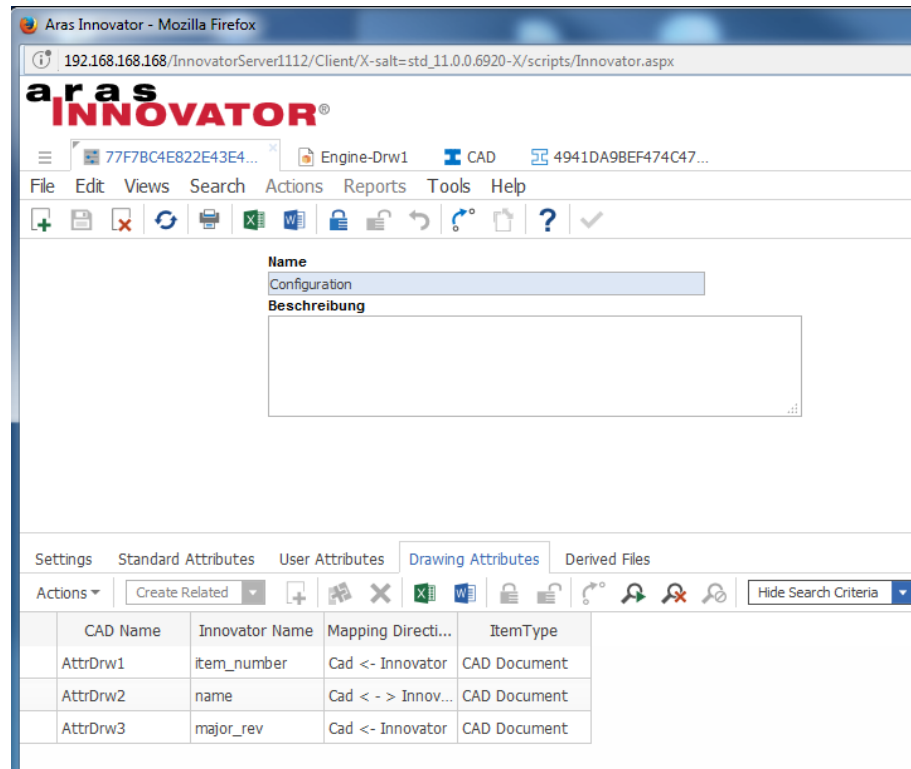

Picture 234: Drawing attributes mapping – Configuration of Drawing attributes in Aras Innovator

After the drawing is created in PDM the CATDrawing file contains the attributes defined in the Drawing Attribute definition in the Aras Innovator configuration (see *Picture 235: Drawing attributes mapping – CATDrawing attribute mapping*).

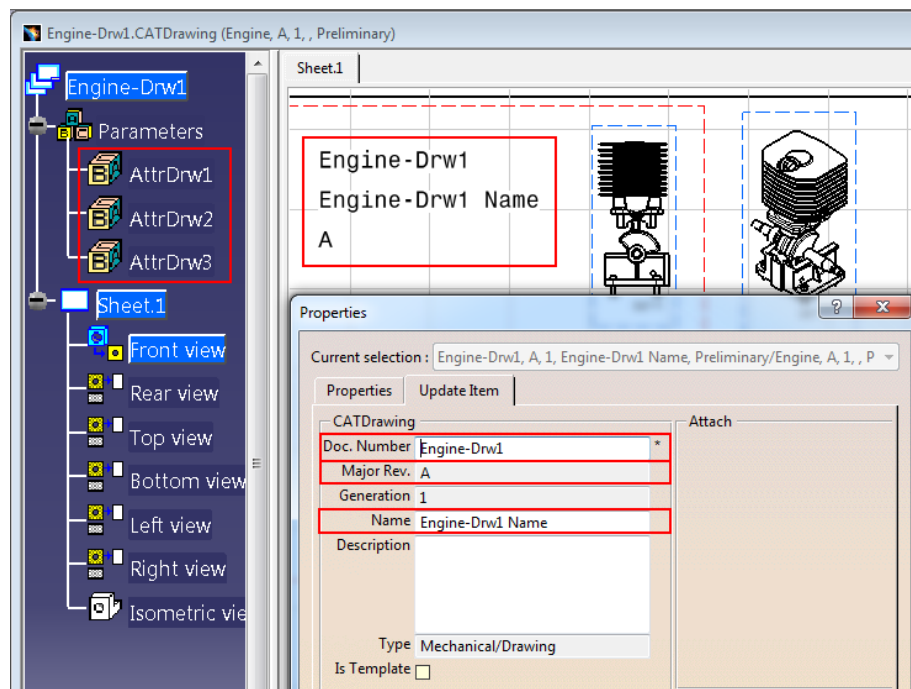

Picture 235: Drawing attributes mapping – CATDrawing attribute mapping

You can modify one of the drawing attributes (see *Picture 236: Drawing attributes mapping – Modify drawing attribute value*).

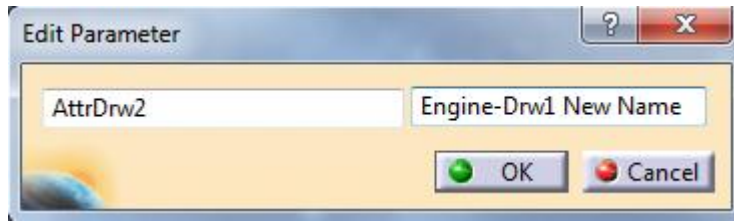

Picture 236: Drawing attributes mapping – Modify drawing attribute value

The modified attribute value is stored in CATIA V5 (see *Picture 237: Drawing attributes mapping – Modified drawing attribute value*).

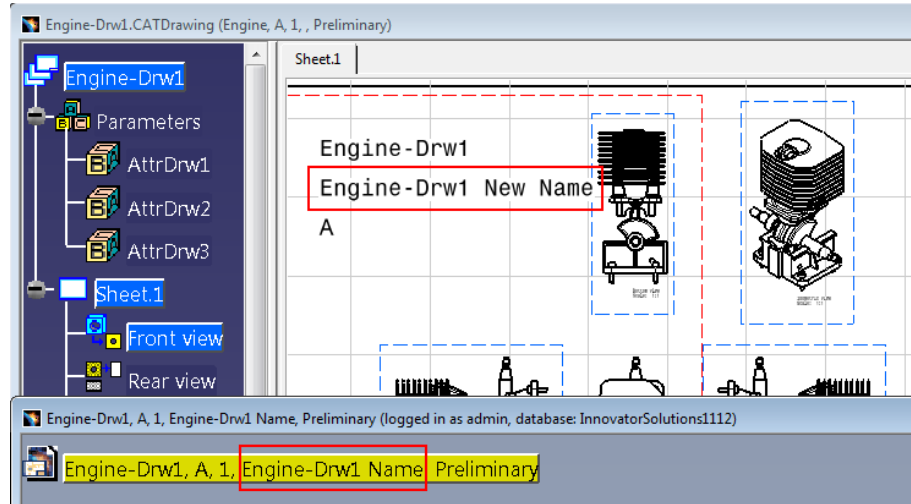

Picture 237: Drawing attributes mapping – Modified drawing attribute value

After a PDM update, the new attribute value is written into its corresponding PDM attribute (see *Picture 238: Drawing attributes mapping – Modified PDM attribute value*).

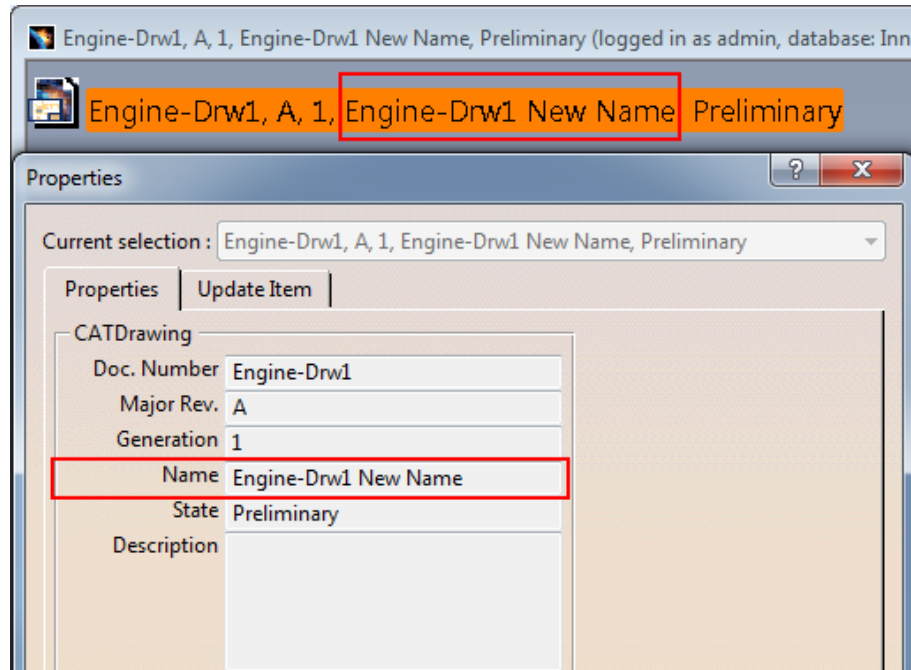

Picture 238: Drawing attributes mapping – Modified PDM attribute value

If, on the other hand, you change one of the mapped PDM attributes, the new value will be written into the CATDrawing attribute the next time the CATDrawing is loaded to CATIA (see *Picture 239: Drawing attributes mapping – PDM attribute value modified from Aras Innovator*).

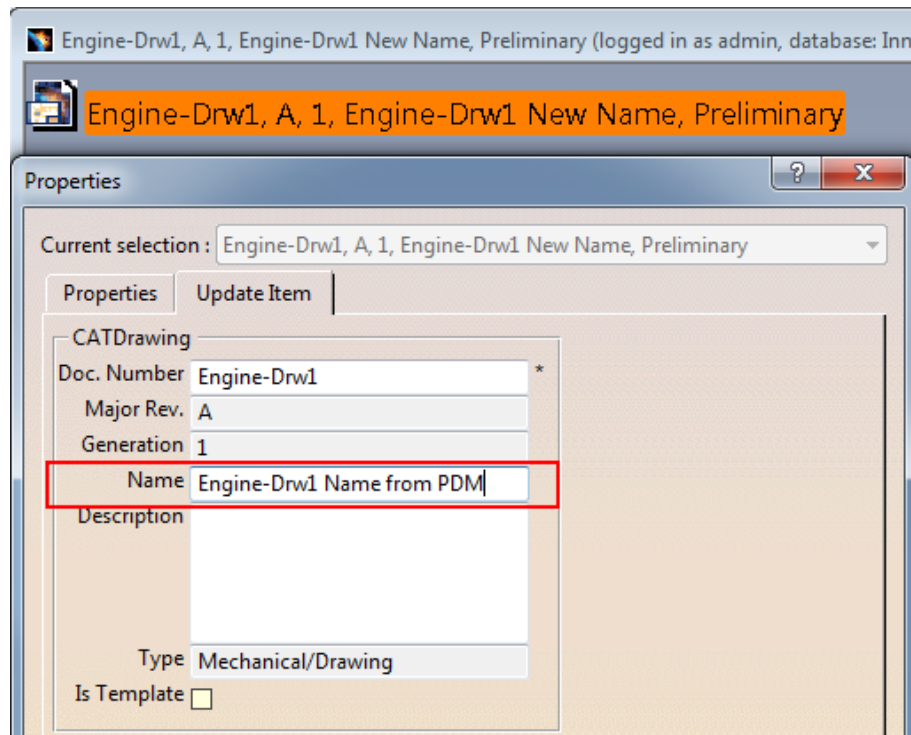

Picture 239: Drawing attributes mapping – PDM attribute value modified from Aras Innovator

You can see the PDM attributes in the parameters of the CATDrawing (see *Picture 240: Drawing attributes mapping – Drawing attribute value changed to PDM attribute value*).

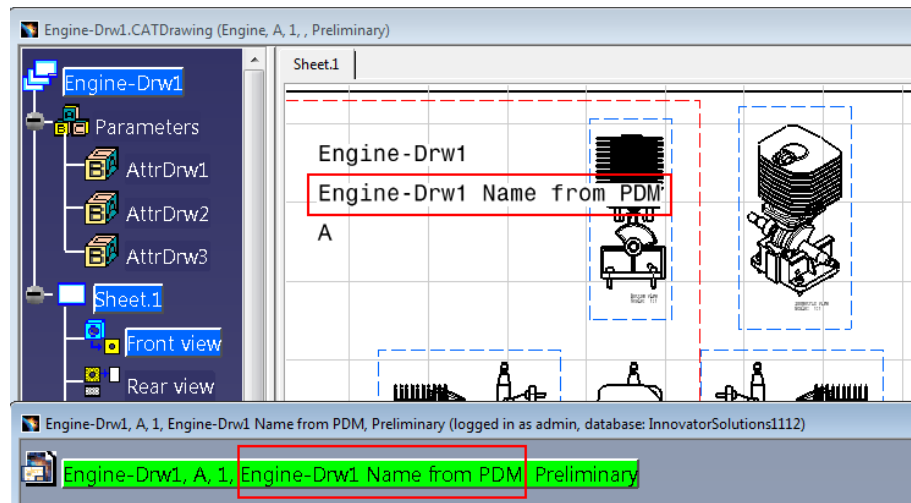

Picture 240: Drawing attributes mapping – Drawing attribute value changed to PDM attribute value

Inertia attributes mapping

You can configure the server to let the CAD client calculate and provide some inertia attribute values (like the center of gravity) when the CAD file is uploaded to the PDM system. These values can be mapped to properties of your CAD or Part items in Aras Innovator.

If an inertia attribute mapping is configured on the server, the calculation of inertia values is performed automatically during the “Update” process whenever a CATPart was created or modified. Inertia values are not calculated for other document types.

Take care that the calculation of the mass can only be accurate if you provide the correct material in your part definition (see *Picture 241: Sample material definition in CATIA*).

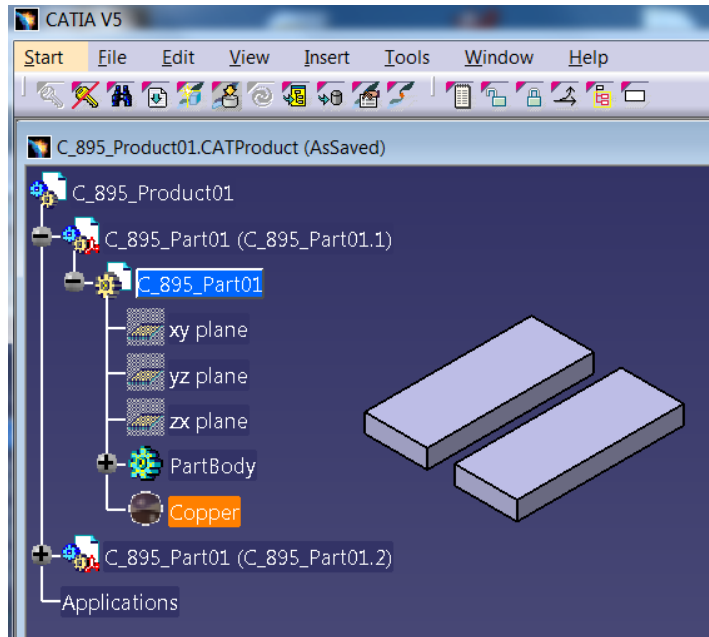

Picture 241: Sample material definition in CATIA

Here are sample pictures of the results of an inertia calculation in CATIA and a mapping to CAD Document item properties in Aras Innovator (see *Picture 242: CATIA tree and inertia properties* and *Picture 243: Inertia properties mapped to Aras Innovator*):

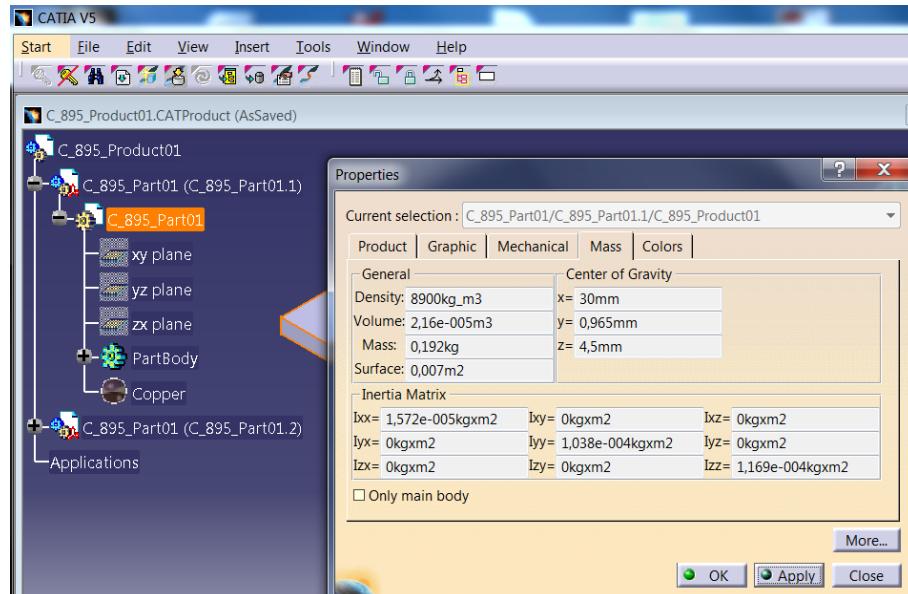

Picture 242: CATIA tree and inertia properties

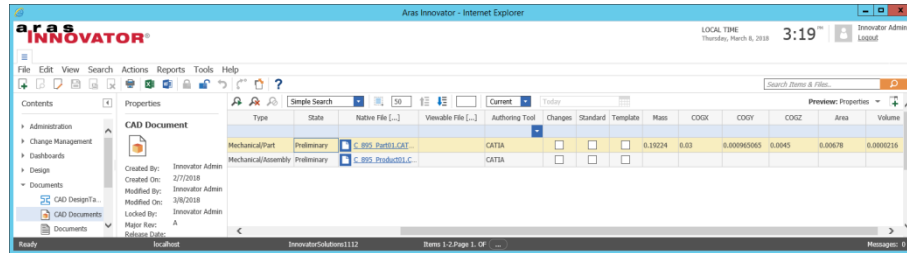

Picture 243: Inertia properties mapped to Aras Innovator

PDM to CAD Attribute Mapping only for CATIA Files claimed by the User

Changed PDM attribute values should only be written into CATIA files that are claimed by the user. This behaviour should be optional.

Allow mapping of Part and CAD Property to the same CATIA Standard Attribute

By default, you can either map a Part or a CAD Document property to a CATIA standard attribute like Nomenclature, Definition, Revision, and Reference Description. This causes a problem if you work in BOM Part Structure Data Model with additional non-BOM CATIA files. For instance, if you map the value of the Part property “name” to the CATIA attribute “Nomenclature” you cannot map any CAD Document property to the same CATIA attribute. This means the CATIA attribute “Nomenclature” cannot be controlled by any Aras Innovator property for a non-BOM CATIA file.

This functionality allows to define a property mapping for both types:

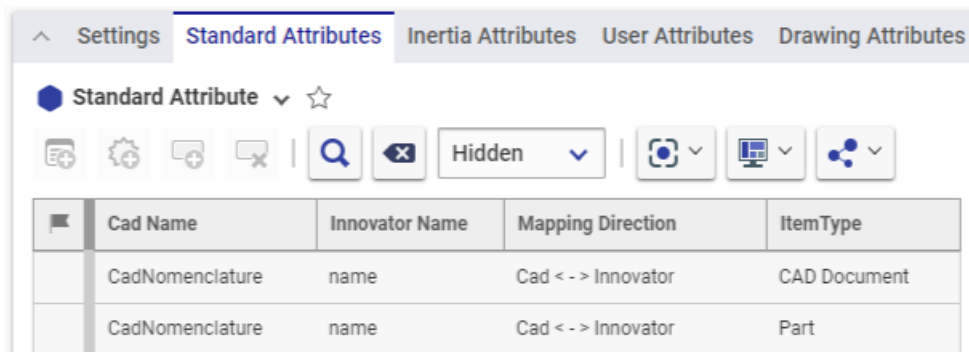

Picture 244: Mapping of CATIA attribute Nomenclature from CAD and Part

The mapping of the Part property is handled with a higher priority. This means only if there is no Part, the mapping of the CAD will be used.

The mapping direction from CATIA to Aras Innovator is not affected.

Internal CATIA Information can be written to user-defined CATIA Properties

The CATIA internal attributes have to be defined in the PDM Workbench Schema file to be copied to the user defined attributes in CATIA. They are marked in red and can be checked in the “Properties” dialog of the CATIA object (see *Picture 245: User-defined attributes with internal CATIA information in “Properties” dialog*).

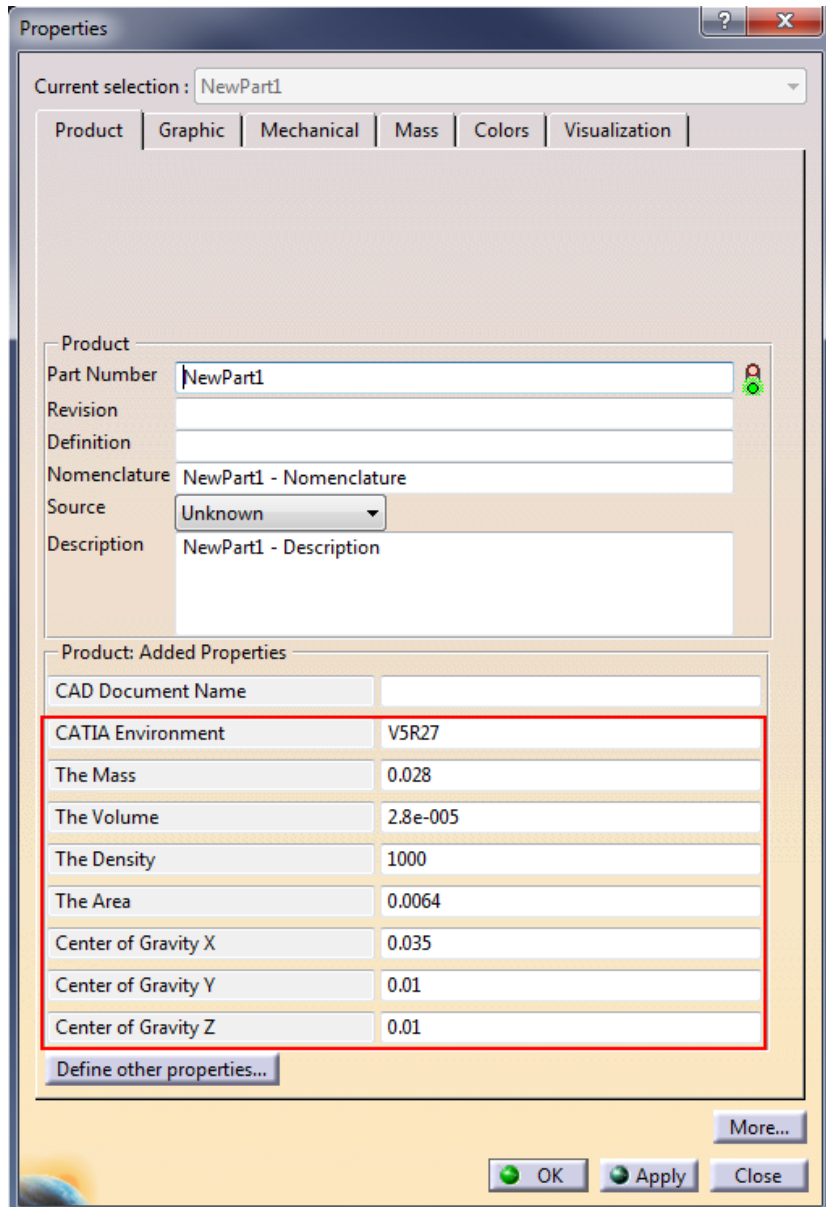

Picture 245: User-defined attributes with internal CATIA information in “Properties” dialog

If these values are configured correspondingly, like for instance “CATIA Environment” in the picture below, then the values are automatically written to the mapped attributes of the PDM object (see *Picture 246: Configuration of user-defined attributes in Aras Innovator*). The “CAD Document Name” is also mapped to an attribute in Aras Innovator; but it is no internal CATIA attribute.

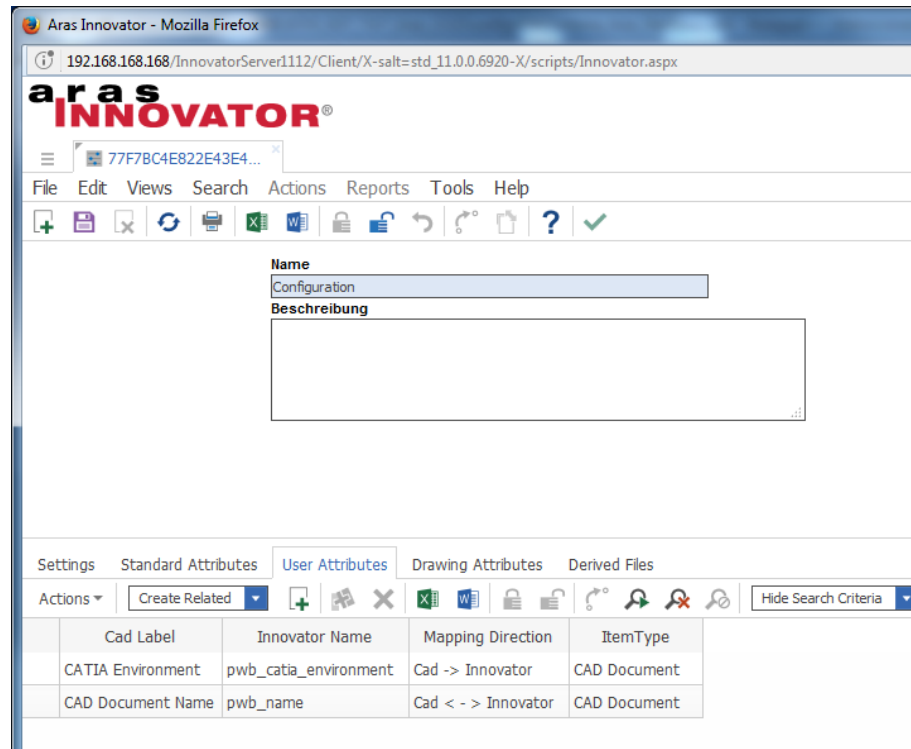

Picture 246: Configuration of user-defined attributes in Aras Innovator

Create CAD Document and Part with Templates

In the dialog which appears after you click on the toolbar action “Create”  the type of the new object can be selected (see *Picture 247: Select a PDM type for the “PDM Create” dialog*).

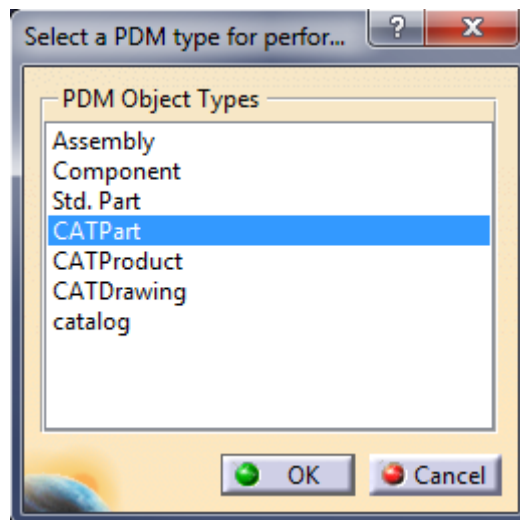

Picture 247: Select a PDM type for the “PDM Create” dialog

If one of those types is selected, then the next dialog opens. You have to select the template for the new object from a dropdown list. The template names are defined in the PDM Workbench configuration file. If you do not select a template an empty CATIA file is opened (see *Picture 248: “PDM Create” dialog for CATPart – Select Template*).

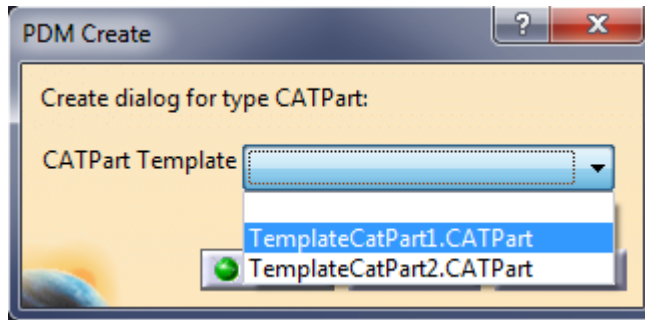

Picture 248: “PDM Create” dialog for CATPart – Select Template

When you confirm the dialog with "OK" the Template File or the empty file is opened in CATIA and the "Update to PDM" dialog is opened. You have to type in the attribute values of the item object and the document object to be created (see *Picture 249: “PDM Create” dialog for CATPart in BOM Part Structure Data Model*) or the document object to be created (see *Picture 250: “PDM Create” dialog for CATPart in CAD Document Structure Data Model*).

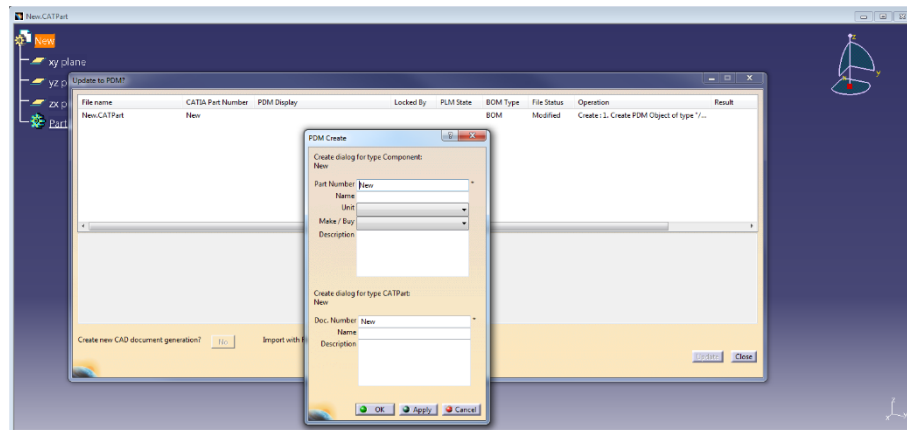

Picture 249: “PDM Create” dialog for CATPart in BOM Part Structure Data Model

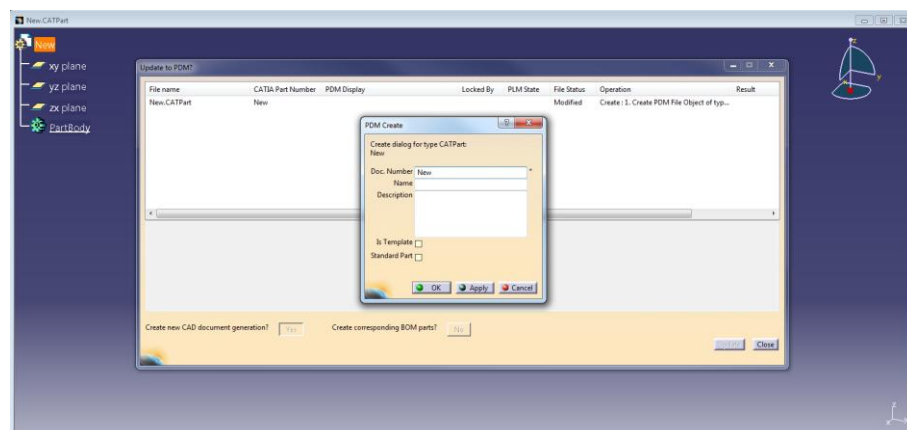

Picture 250: “PDM Create” dialog for CATPart in CAD Document Structure Data Model

Then you have to change the name and click on the “OK” button. A normal update is performed, which creates a part with the corresponding CAD Document in the PDM system and uploads the file (see *Picture 251: Created Part*).

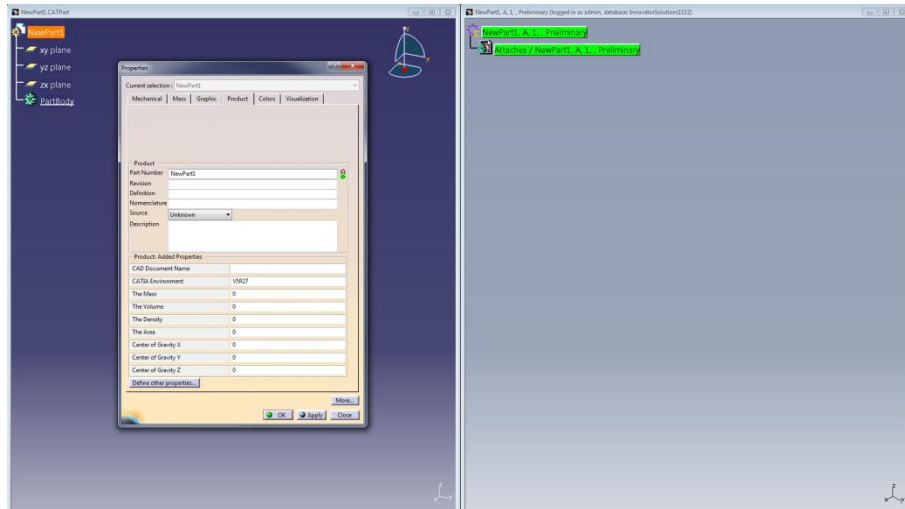

Picture 251: Created Part

Manage CATIA Templates in Aras Innovator

The existing “Template File” functionality, where template CATIA files are stored on a local directory which is accessible from CATIA V5, is extended such that the file templates can be stored in PDM.

The “Template File” functionality can be used in two ways:

1. When new CATIA document objects are created from the “Create” command in the PDM Workbench toolbar.

Example:

Create CATPart (see *Picture 252: “Template File” functionality – Creating a CATPart*).

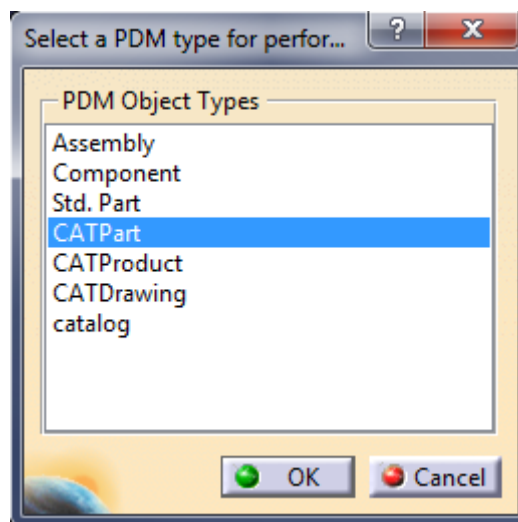

Picture 252: “Template File” functionality – Creating a CATPart

If templates are configured, then you get to choose a Template File Name (see *Picture 253: “Template File” functionality – Selecting a Template File*).

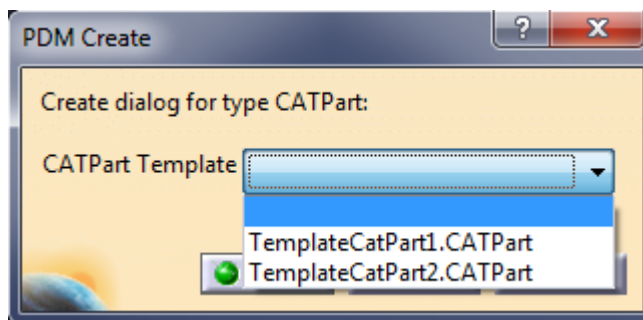

Picture 253: “Template File” functionality – Selecting a Template File

If no Template File is chosen a new CATIA CATPart file will be created.

2. When a PDM structure is loaded where one or more parts do not have a related CATIA file.

This use case is applicable when using the BOM Part Structure Data Model ("UseBomPartStructure" is set to "true").

Example:

Create an Assembly (see *Picture 254: “Template File” functionality – Creating an Assembly*).

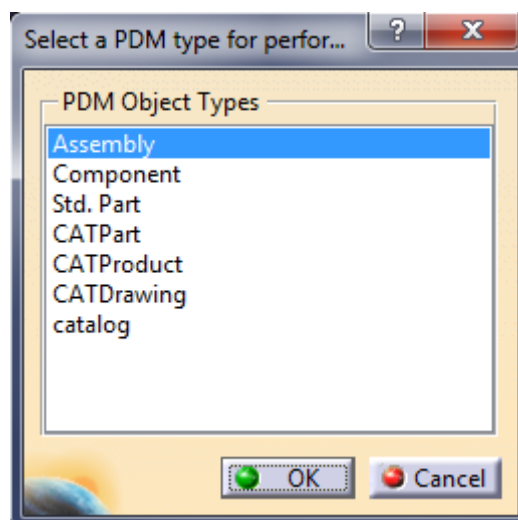

Picture 254: “Template File” functionality – Creating an Assembly

Fill all the necessary Assembly information on the “PDM Create” dialog and click OK.

The created Assembly is opened in a new PDM window.

Right click on the Assembly node and chose "Load" from the context menu.

In this case the corresponding CATIA structure nodes are created on the fly using the first Template File in the list, which is defined as the default template.

Template File Support for “Create Part” with Templates depending on the Part Type

Originally the “Create” functionality only creates the “Part” business item in the database when a part type is selected, without a corresponding CAD Document item.

An extension of the “Create” functionality allows to create Part items with their corresponding CAD Document, and the native file of this CAD Document can be based on a list of Template Files which is defined specifically for this part type.

These Part items can also be created in the context of a parent Assembly.

Usage

If a CATIA file type, for example “CATProduct”, is selected in the “Create” action, a list which contains all the Template Files of this file type is shown. The user can select one of the Template Files from the list.

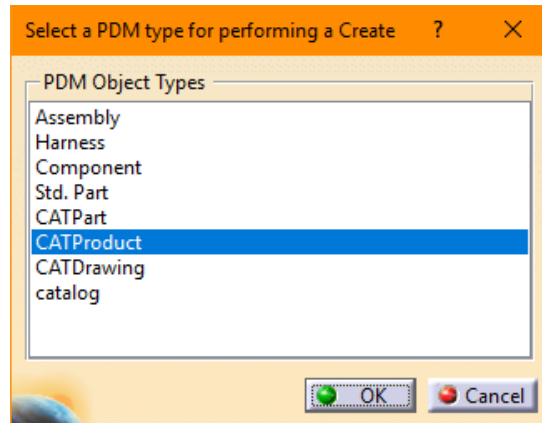

Picture 255: Creating a new CATProduct CAD item

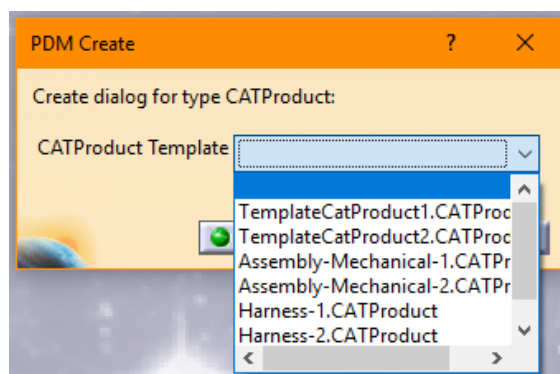

Picture 256: List containing all CATProduct Template Files

The “Create” functionality will create both the CAD Document and the corresponding Part item, with the Part having the “default” classification.

With the new functionality it is possible to create one of the specific part types, and to be able to choose the Template File from a list specific for that part type:

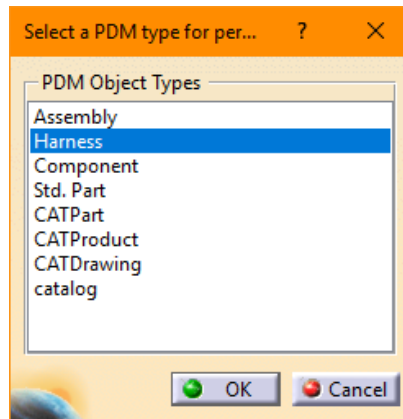

Picture 257: Creating a new Part item

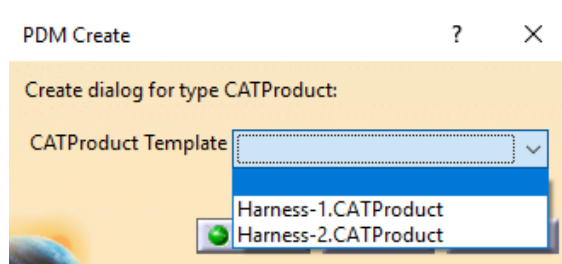

Picture 258: List containing Template Files corresponding to the selected Part

Here, for the part type “/Part/Design/Harness” two specific Template Files for CATProduct are defined.

It is also possible to create a Part item with a corresponding CATIA Template File, as described above, in the context of a parent CATProduct. For this, a CATProduct in a CATIA structure loaded from PDM has to be selected, and the PDM Workbench context action “PDM Create in Context” has to be clicked:

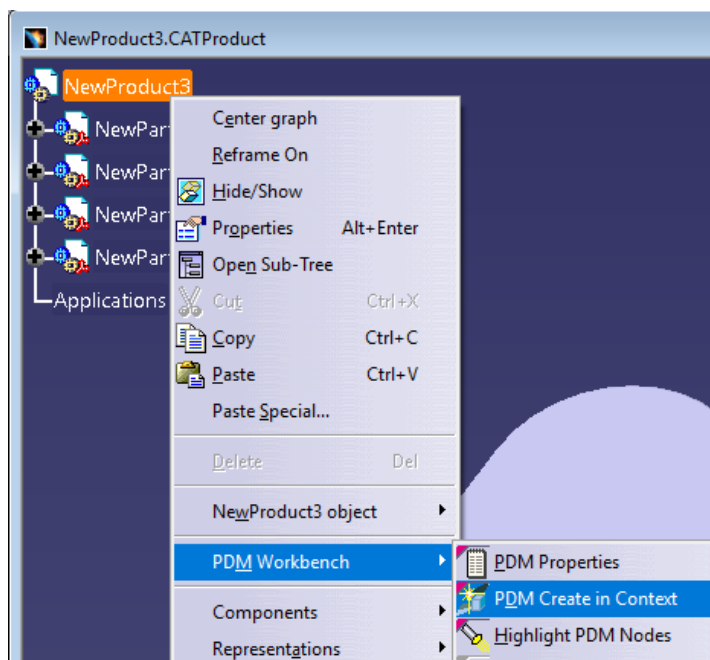

Picture 259: “PDM Create in Context” context menu entry

This will display the same dialogs as the regular “Create” process:

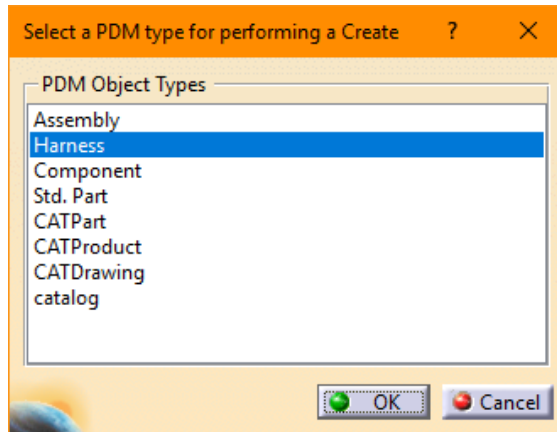

Picture 260: Creating a new Part item in context

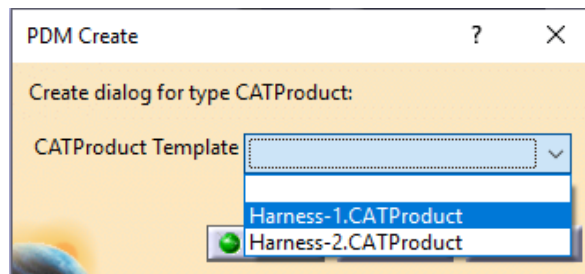

Picture 261: List containing Template Files corresponding to the selected Part in context

→ The following “Update” process includes adding the instance of the new Part to the parent Assembly:

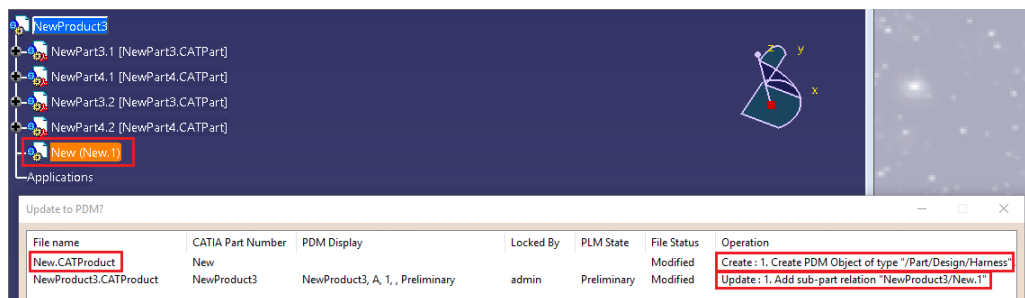

Picture 262: “Update to PDM” dialog after “PDM Create in Context” action

Standard Part Support

When CATParts which are defined as corresponding to a Standard Part are added to a CATProduct structure the “Update” process will not try to create the corresponding Part and CAD Document items in PDM. Instead, the Standard Part item which has the same Part Number as the CATPart’s CATIA Part Number will be queried and added to the PDM structure instead. Using this functionality Standard Part geometry can be added to a PDM structure without having to first load the Standard Parts into the CATIA session.

“Standard Part” Functionality for BOM Part Structure Data Model

In the BOM Part Structure Data Model, it is possible to define part items and their corresponding CAD Document items as Standard Parts. Standard Parts are supposed to be parts which are used in a wide variety of different contexts, and which are generally not modified by the designer, only used in the PDM structures that the designer works on.

You can query for a Standard Part explicitly (see *Picture 263: Querying for a Standard Part*). Please note that regular users cannot claim and modify Standard Parts, they can only use them in their structures:

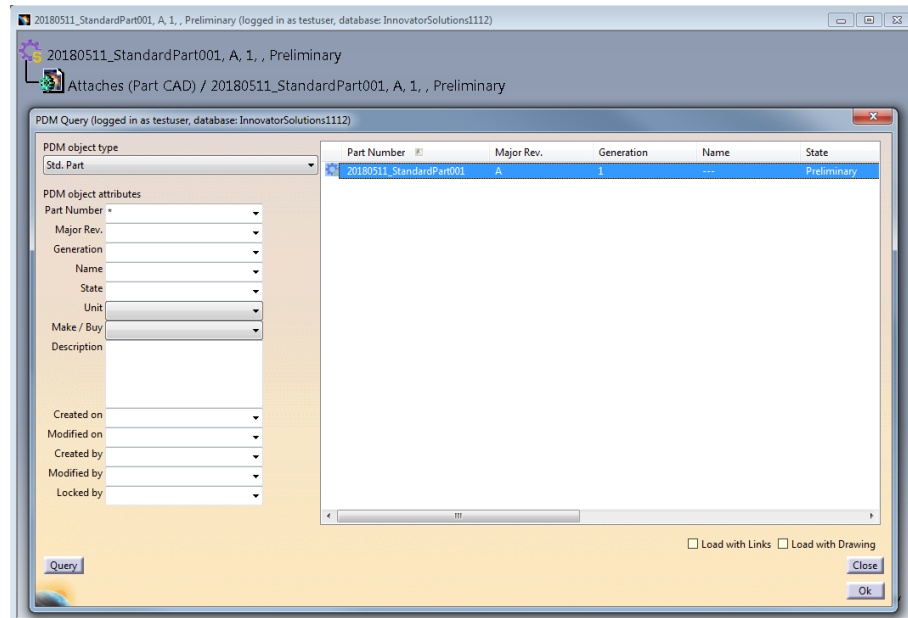

Picture 263: Querying for a Standard Part

Standard Parts can be used like regular parts. The exceptions are that regular users cannot create or update Standard Parts, and it is possible to import CATProduct structures which contain Standard Parts which are already defined in PDM. In that case the existing Standard Part items are used for that structure.

“Standard Part” Functionality for CAD Document Structure Data Model

The “Standard Part” functionality is also available in the CAD Document Structure Data Model.

After the Standard Part CAD Document items have been created any regular CAD user can query for them, by checking the “Standard Part” check box in the “PDM Query” dialog.

Regular users cannot claim or otherwise modify Standard Part CAD Documents (see *Picture 264: Using Standard Parts as a regular user*).

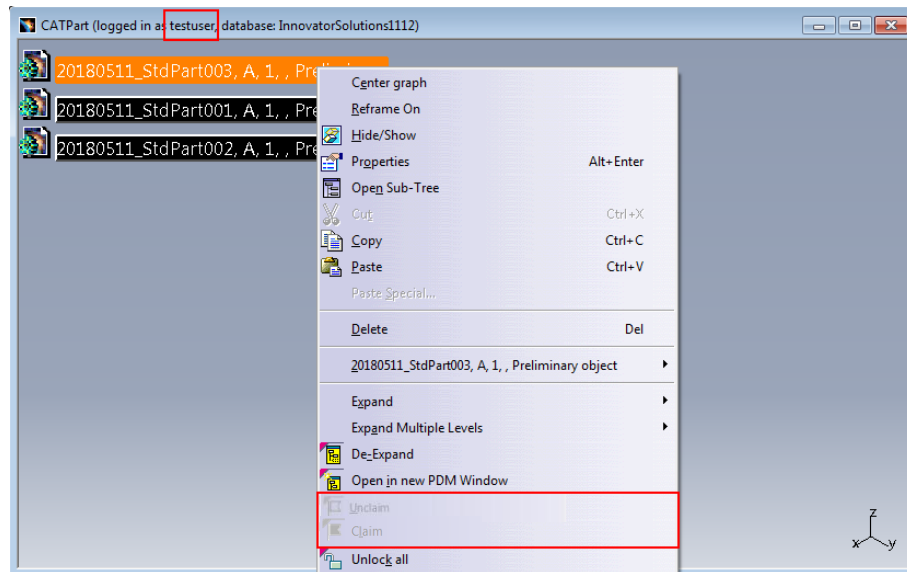

Picture 264: Using Standard Parts as a regular user

They can use Standard Parts in the CATIA structures that they work on (see *Picture 265: Using Standard Parts in CATIA structures*).

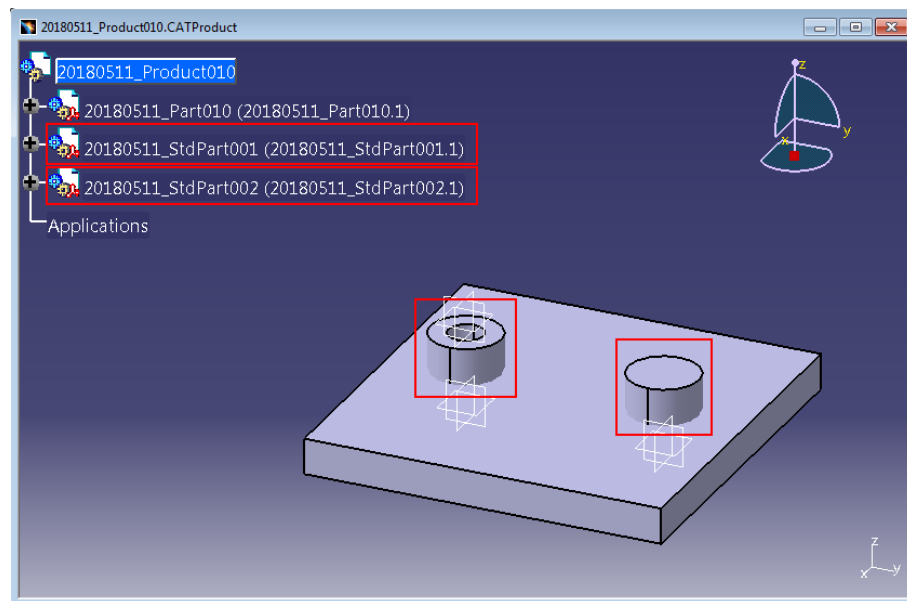

Picture 265: Using Standard Parts in CATIA structures

Adding Standard Parts to an existing structure at first does not seem different from adding other CATPart nodes ... (see *Picture 266: "Update to PDM" dialog with Standard Parts*)

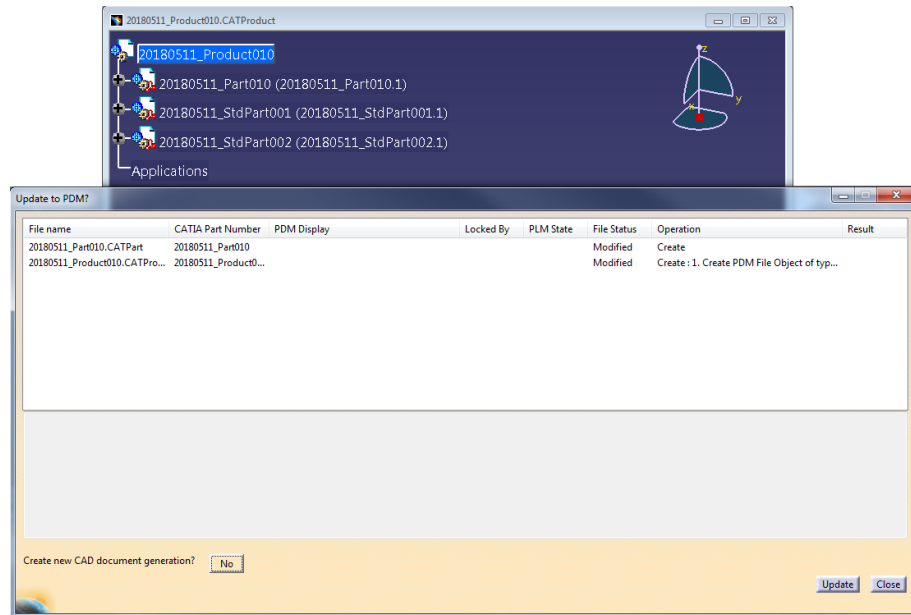

Picture 266: “Update to PDM” dialog with Standard Parts

... but the Standard Parts are not created by the “Update” process, but the existing ones, which have been created by the “Standard Part Administrator”, are used (see *Picture 267: “Update to PDM” dialog with Standard Parts – Result* and *Picture 268: Existing Standard Parts being used in a new structure*).

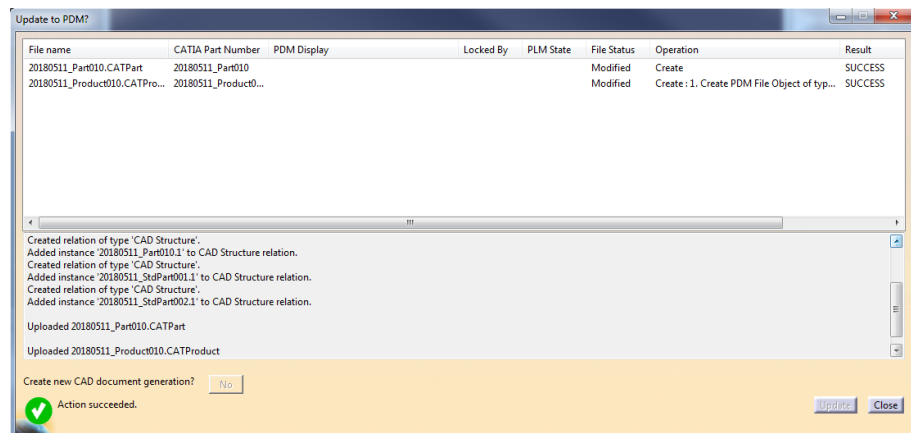

Picture 267: “Update to PDM” dialog with Standard Parts – Result

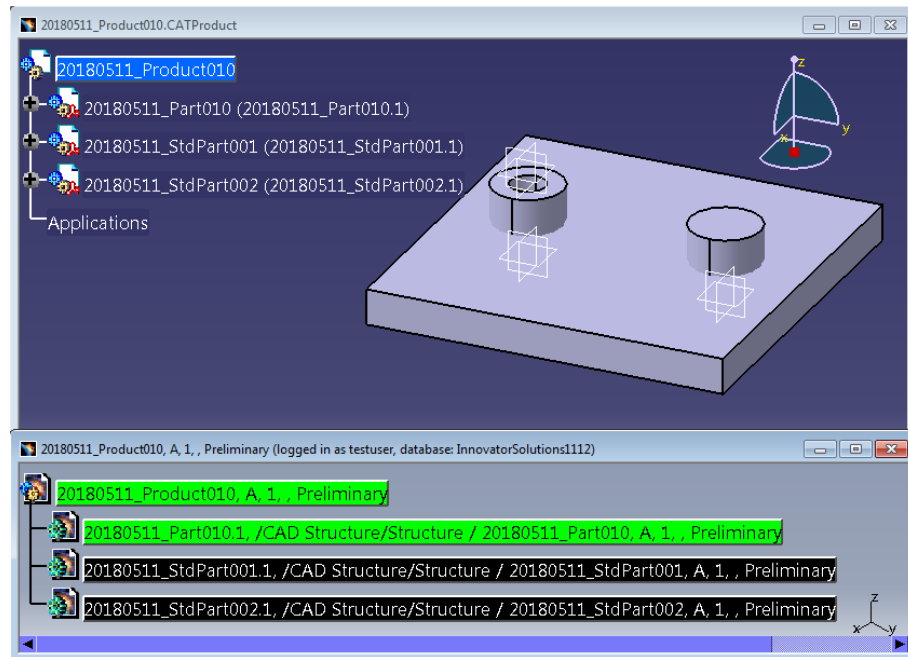

Picture 268: Existing Standard Parts being used in a new structure

Standard Part CATParts can be inserted to a CATProduct structure manually or by the “CATIA Catalog” functionality. For this the standard CATParts have to be added to a CATIA Catalog file first.

The Catalog file can reside in any client directory which is accessible to CATIA V5. It can be a network drive (see *Picture 269: CATIA Catalog containing Standard Part CATParts*).

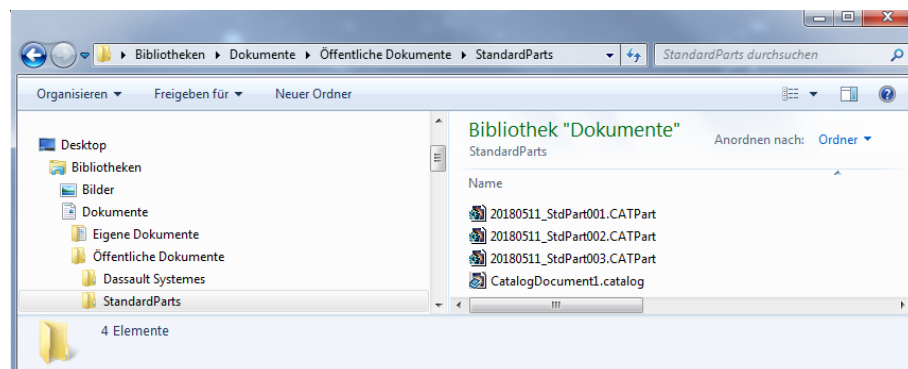

Picture 269: CATIA Catalog containing Standard Part CATParts

Then the Standard Parts can be inserted to a CATProduct structure (see *Picture 270: Standard Part CATParts created from a Catalog*).

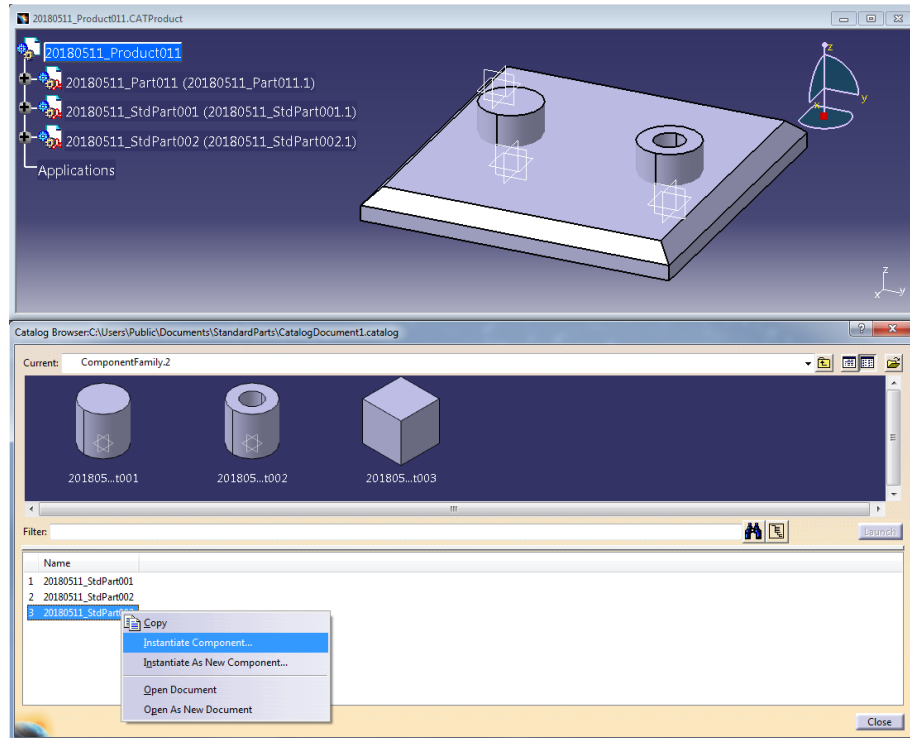

Picture 270: Standard Part CATParts created from a Catalog

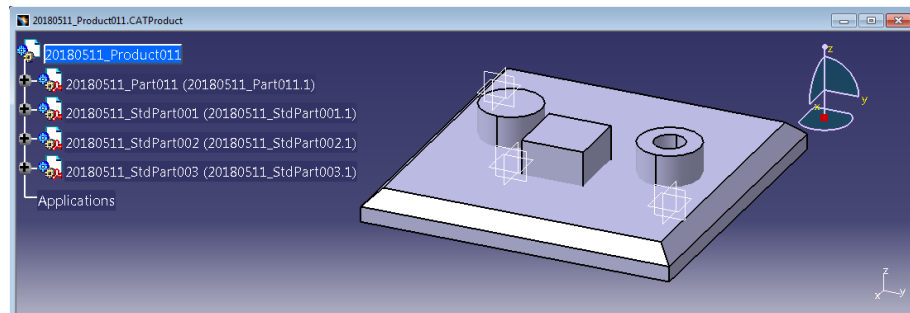

Picture 271: Inserted Standard Parts

In the “Update” process the Standard Part item from the database is taken (see *Picture 272: “Update to PDM” dialog with Standard Parts*).

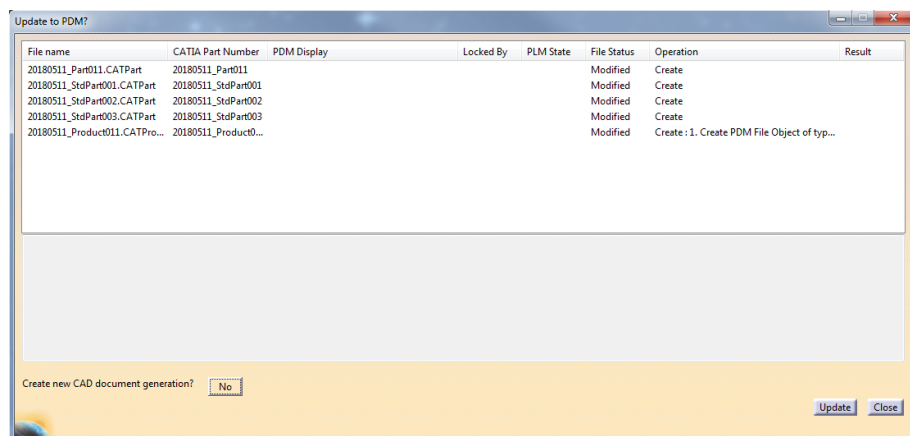

Picture 272: “Update to PDM” dialog with Standard Parts

The update results are displayed in the text area of the window (see *Picture 273: Update result*).

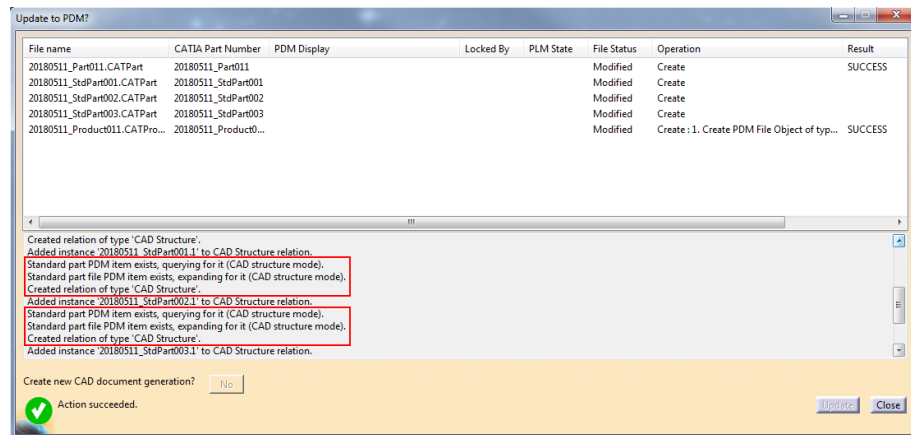

Picture 273: Update result

It is important to make sure that the Standard Part CATPart files in the Aras Innovator vault and in the local directory are exactly the same.

As with regular CATParts, the new Standard Part CATPart node is added to the CAD Document structure.

You can verify this with the “PDM Structure” button of the toolbar (see *Picture 274: “Show PDM Structure” icon*).



Picture 274: “Show PDM Structure” icon

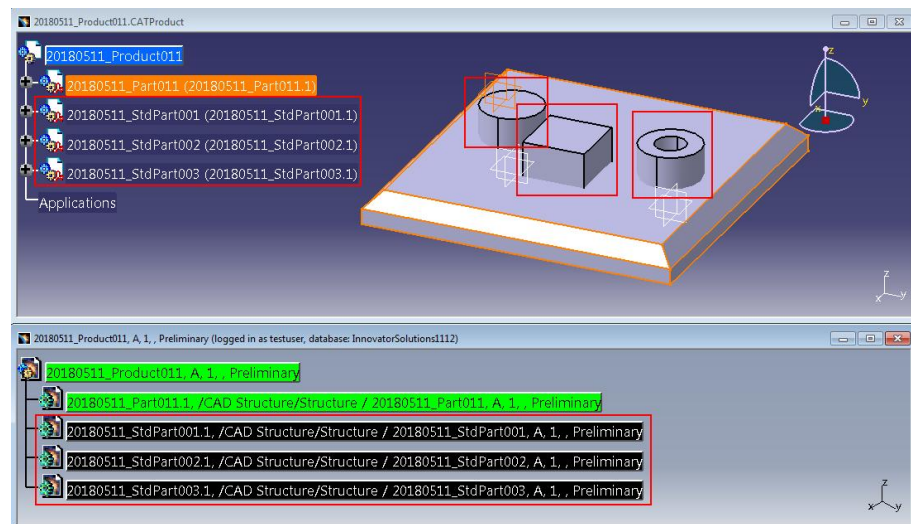

Picture 275: CAD Document structure containing Standard Parts

CATIA Design Table Support

It is possible to load and update text files or Microsoft Excel files which contain CATIA Design Table information.

You can create a Design Table for a CATPart or a CATProduct (see *Picture 276: CATPart with Design Table*).

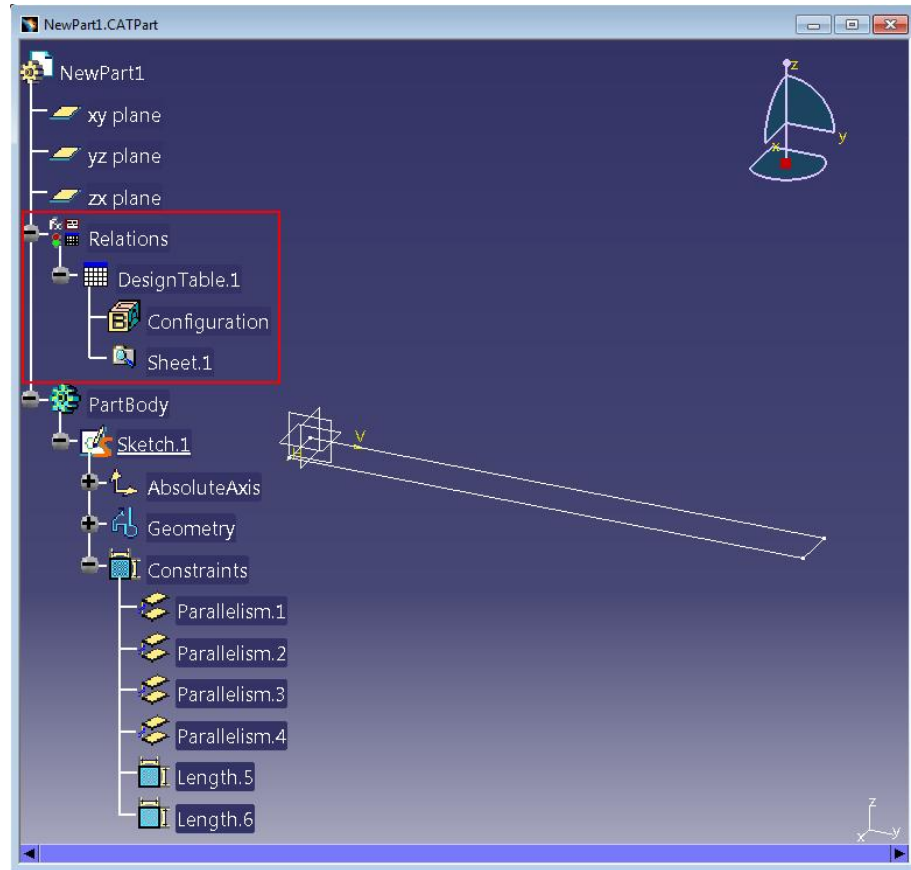

Picture 276: CATPart with Design Table

Updating to PDM will create a Document item for the Design Table and upload the file (see *Picture 277: "Update to PDM" dialog containing a Design Table*).

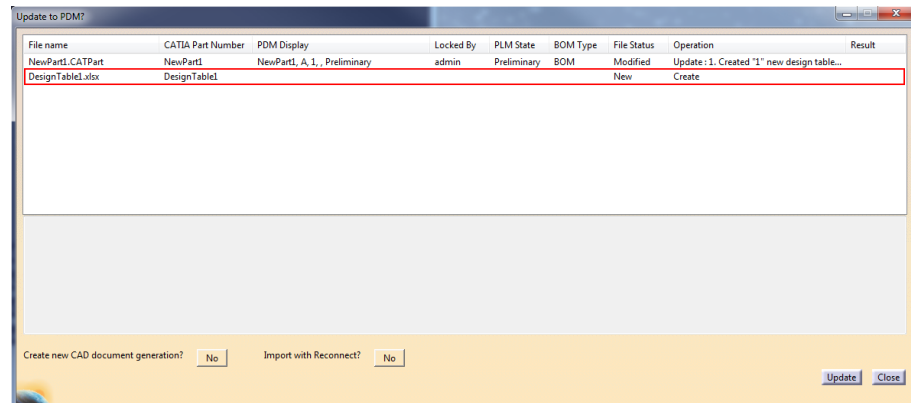

Picture 277: "Update to PDM" dialog containing a Design Table

After the update the Design Table is related to the CAD Document (see *Picture 278: Design Table document related to CAD Document*).

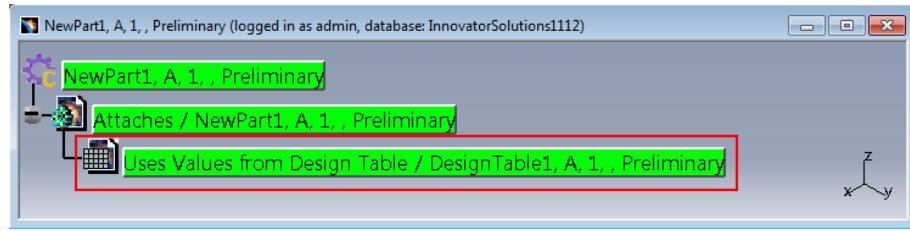

Picture 278: Design Table document related to CAD Document

The Design Table file can be modified and uploaded to PDM again (see *Picture 279: Editing a Design Table*, *Picture 280: Adding a line to the Design Table Excel sheet*, and *Picture 281: The Design Table is updated in the CATIA session*).

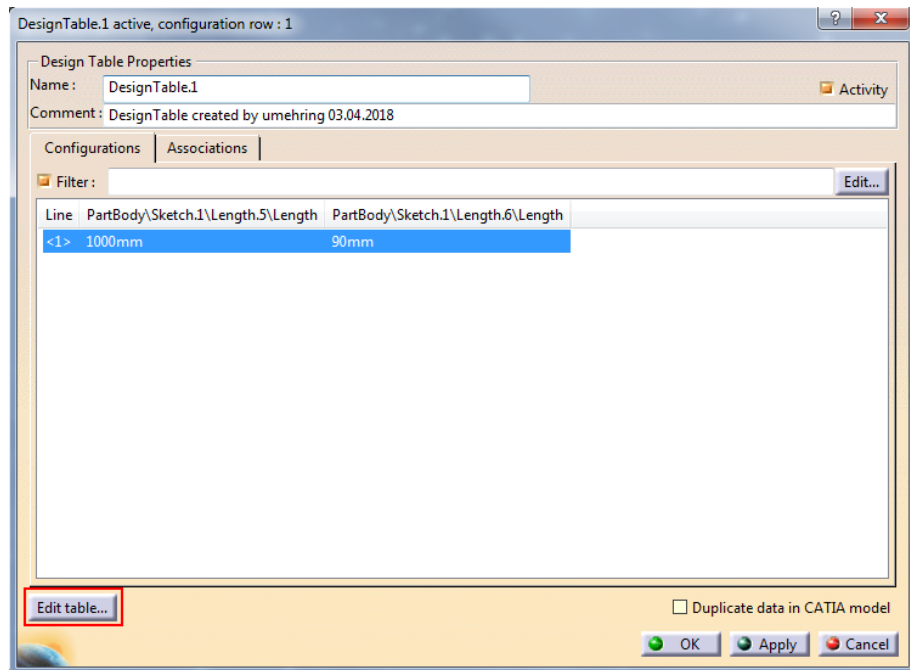

Picture 279: Editing a Design Table

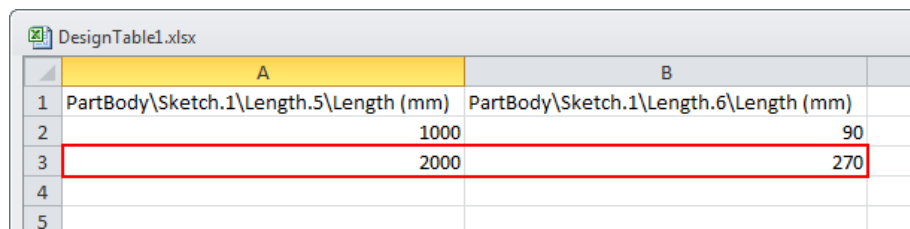

Picture 280: Adding a line to the Design Table Excel sheet

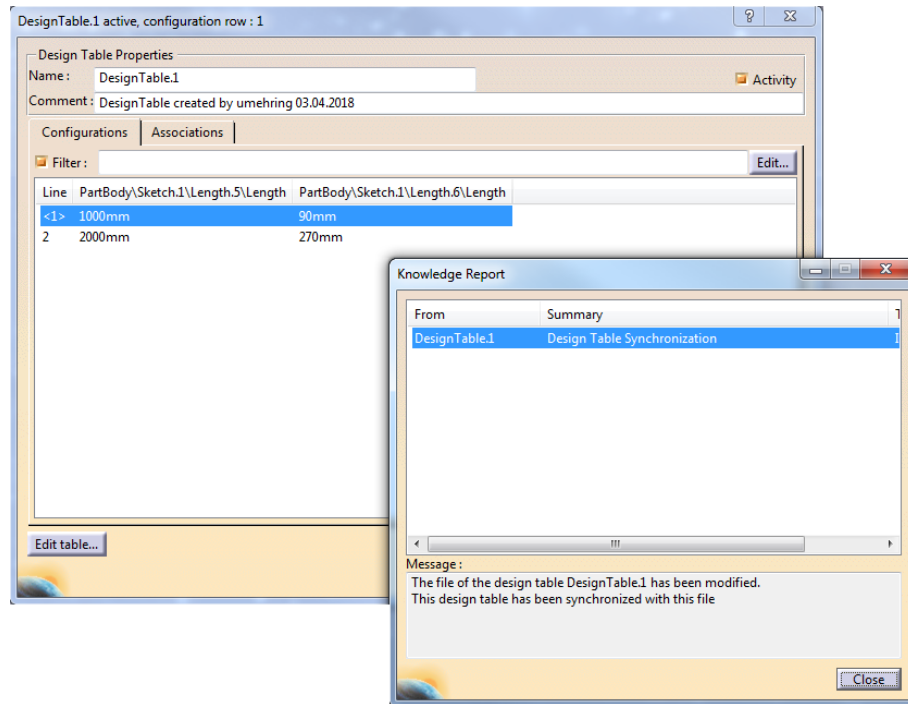

Picture 281: The Design Table is updated in the CATIA session

Refreshing the PDM Structure window shows that both the CATIA document and the Design Table are modified (see *Picture 282: Refreshed PDM Structure window containing the Design Table*).

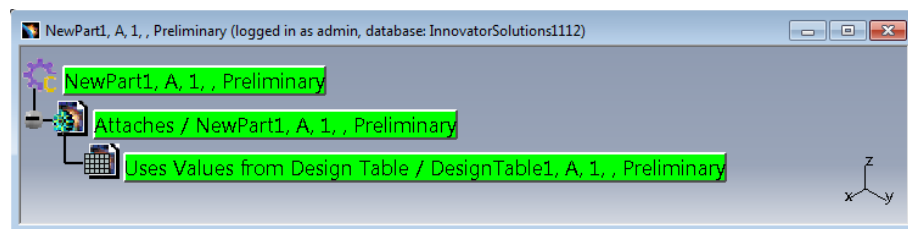

Picture 282: Refreshed PDM Structure window containing the Design Table

The "Update" process uploads both changed files.

When the "Design Table" functionality is switched on the Design Table files that are related to CAD Documents are also downloaded when the CATIA files are downloaded.

Archive Support

It is possible to compress a complete CATProduct substructure into one Zip file and to manage this compressed file in PDM. This makes it possible to hide a complicated CATProduct structure in one CAD Document if it is not necessary to manage the structure information in PDM.

Any CATProduct substructure which has not been created in PDM can be defined as an archive (see *Picture 283: Defining a CATProduct structure as an archive*).

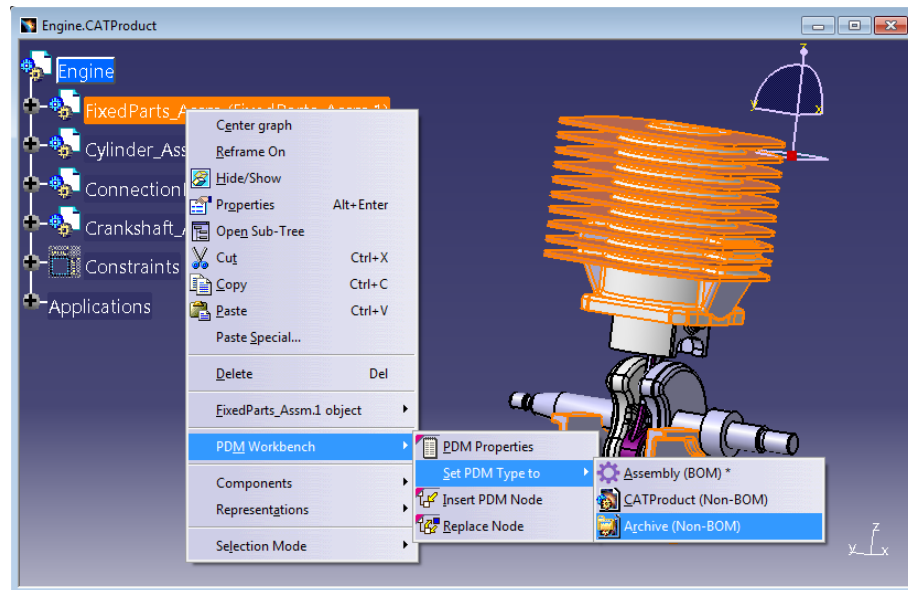

Picture 283: Defining a CATProduct structure as an archive

If this is done the subsequent “Update” process compresses this CATProduct structure into one single ZIP file and manages this ZIP file as a CAD Document in PDM instead of the normal CATProduct structure (see *Picture 284: Resulting archive CAD Document in PDM*).

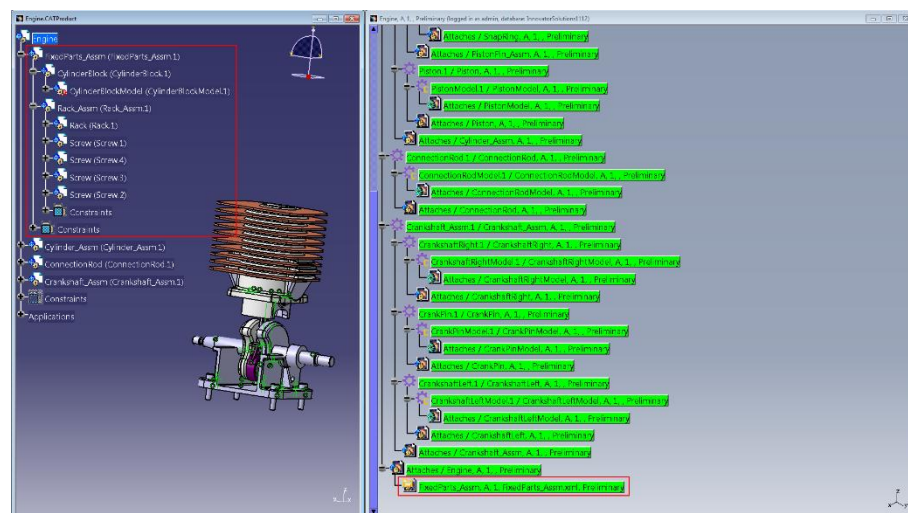

Picture 284: Resulting archive CAD Document in PDM

CATIA Catalog Support

CATIA Catalogs for CATParts are supported. The Catalogs can be created and updated by a “Standard Part Administrator”. The “CATIA Catalog” functionality supports CATParts used as “Standard Parts”, as “Templates” or CATParts holding a “Power Copy”.

The “CATIA Catalog” functionality adds the Catalog keywords “PWB_CAD”, and in case of BOM-CATParts “PWB_PART”. The values of these keywords must not be changed by a user.

During open a Catalog in the CATIA Catalog Editor or Catalog Browser using the PDM Workbench, placeholder files for the referenced CATParts in Aras Innovator are automatically created in the PDM Workbench exchange directory. The actual geometry of a referenced CATPart will be fetched from Aras Innovator as soon as the geometry is needed by the native “CATIA Catalog” functionality.

Create Catalog

All CATParts added to a Catalog must be loaded from Aras Innovator in the current CATIA session in design mode.

Use native CATIA functionality *Add Component* → *Select document in Session* to add a CATPart to the Catalog (see *Picture 285: Add Component to Catalog*). You can also select an external feature of a CATPart loaded from Aras Innovator (PowerCopy).

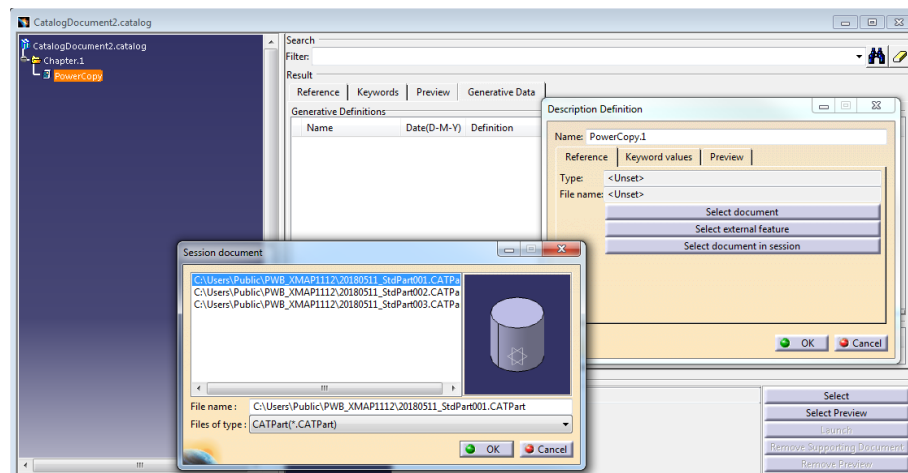

Picture 285: Add Component to Catalog

Use “Local preview” to avoid the download of the CATParts to show the preview (see *Picture 286: Select “Local preview”*).

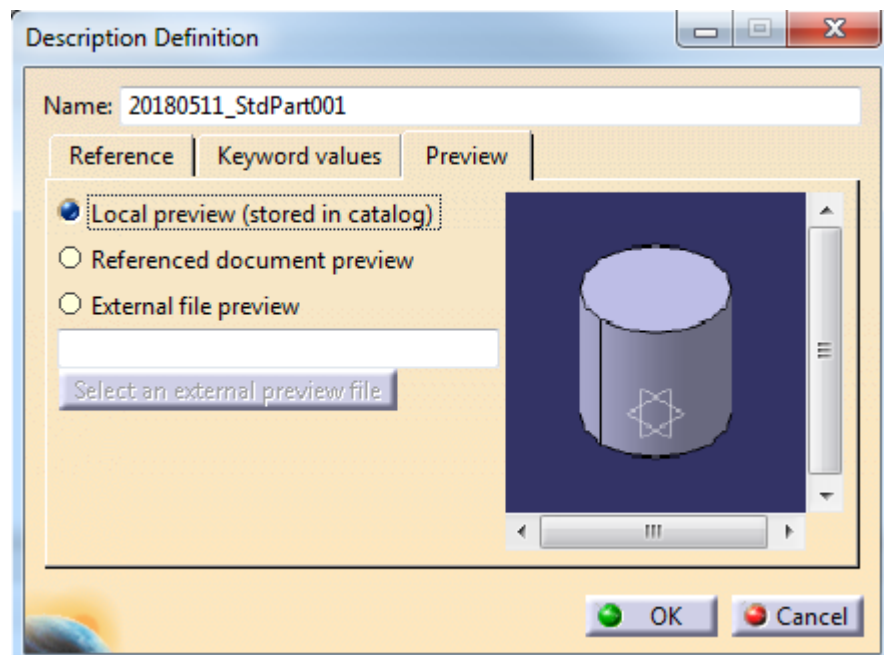

Picture 286: Select “Local preview”

When the needed CATParts are added you can use the normal “Update” functionality to store the Catalog document in Aras Innovator (see *Picture 287: Store Catalog document in Aras Innovator*).

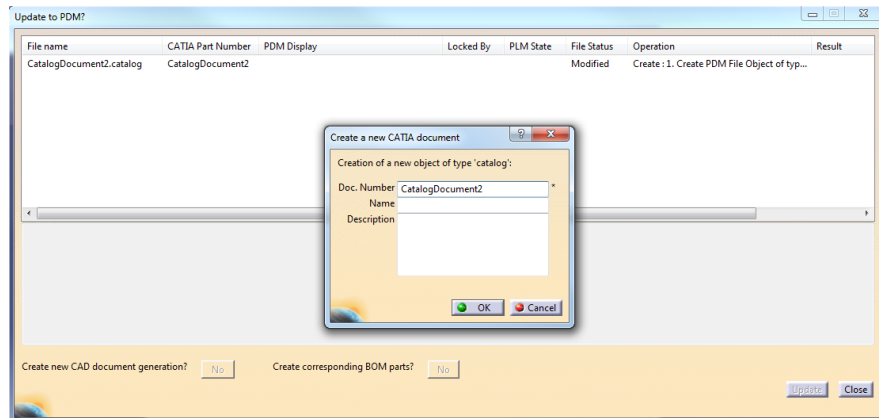

Picture 287: Store Catalog document in Aras Innovator

During update the Catalog will be renamed like according to the Document Number. The keywords “PWB_CAD”, and in case of BOM-CATParts “PWB_PART” are automatically added during “Update” process (see *Picture 288: Catalog editor after update*).

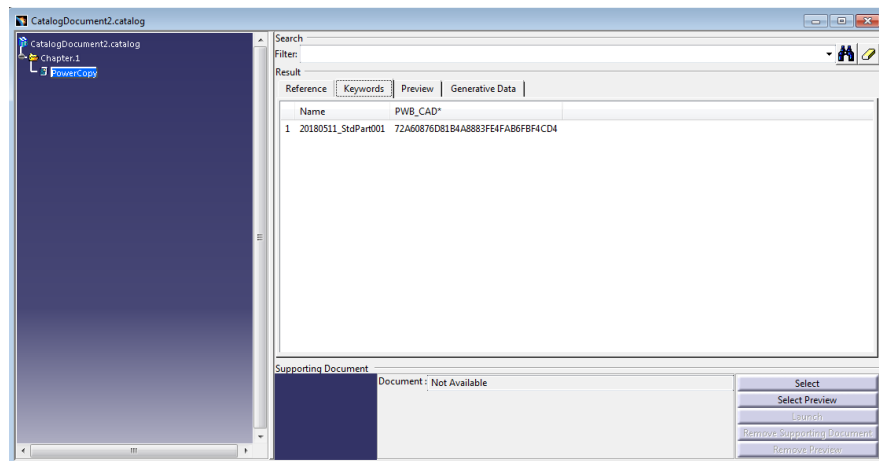

Picture 288: Catalog editor after update

Update Catalog

To Update a Catalog you have to be a “Standard Part Administrator”. Use the “PDM Query” functionality for “catalog”, then use “Open Catalog for Edit” (see *Picture 289: Open Catalog for Edit*).

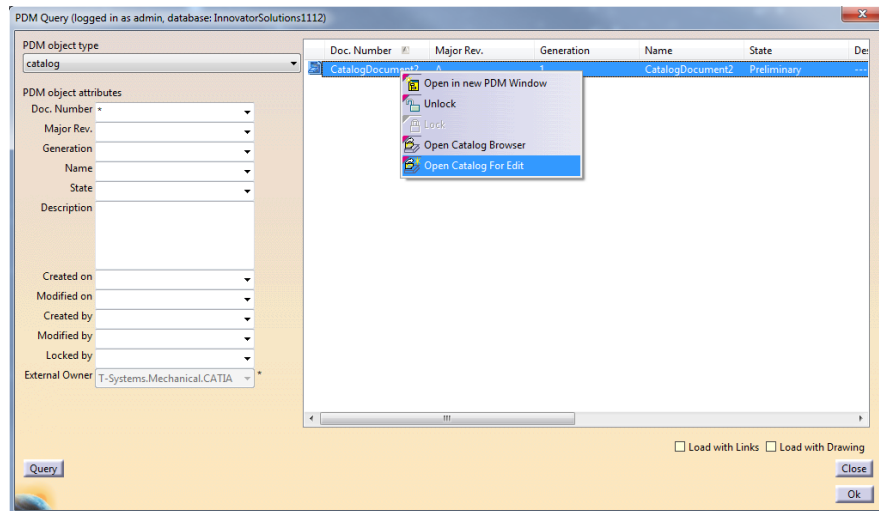

Picture 289: Open Catalog for Edit

Now you can add or remove CATParts from the Catalog. All CATParts added to a Catalog must be loaded from Aras Innovator in the current CATIA session in design mode.

Use the “Update” process to store the changes to Aras Innovator.

Open Catalog Browser

To use the Catalog Browser there has to be an active CATProduct or CATPart window.

Use the “PDM Query” functionality for “catalog” then use “Open Catalog Browser” (see *Picture 290: Open Catalog Browser*).

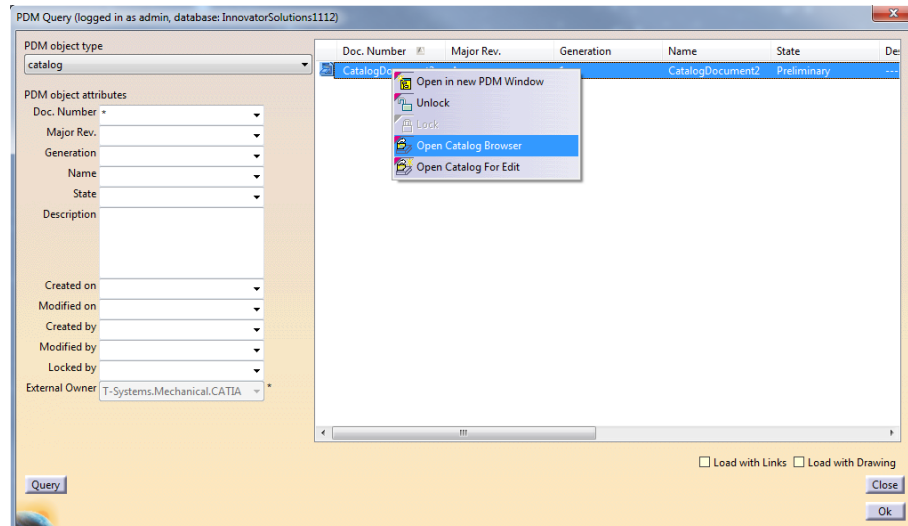

Picture 290: Open Catalog Browser

The Catalog Browser will be opened (see *Picture 291: Catalog Browser*).

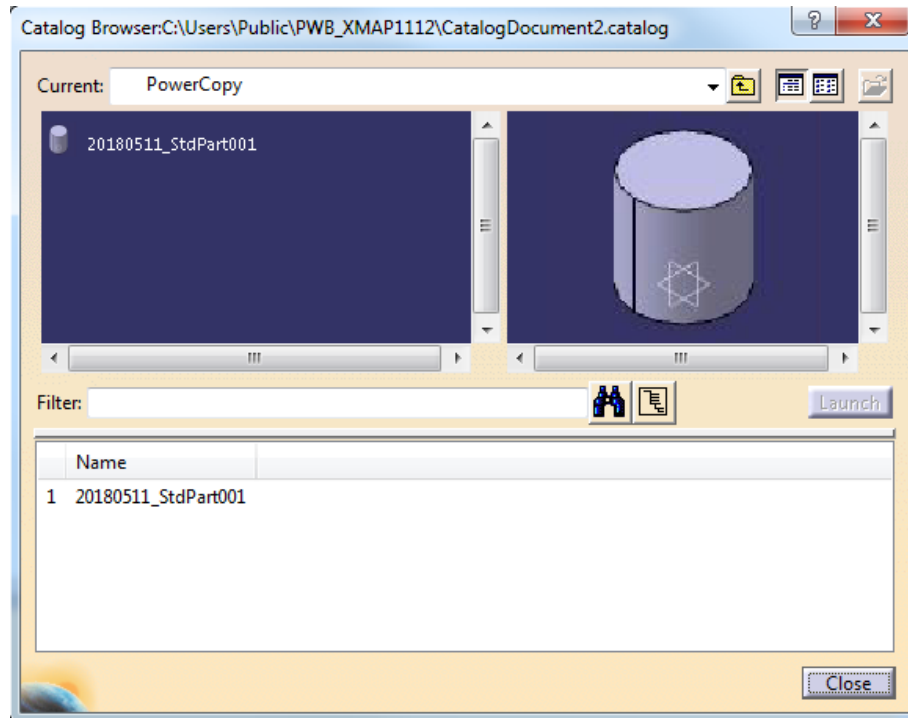

Picture 291: Catalog Browser

You can use the Catalog Browser like a native CATIA Catalog Browser.

The function “Open As New Document” opens a new file with the same Part Number like the original CATPart, so you have to change the Part Number of the new document before using “Update” (see *Picture 292: Open As New Document*).

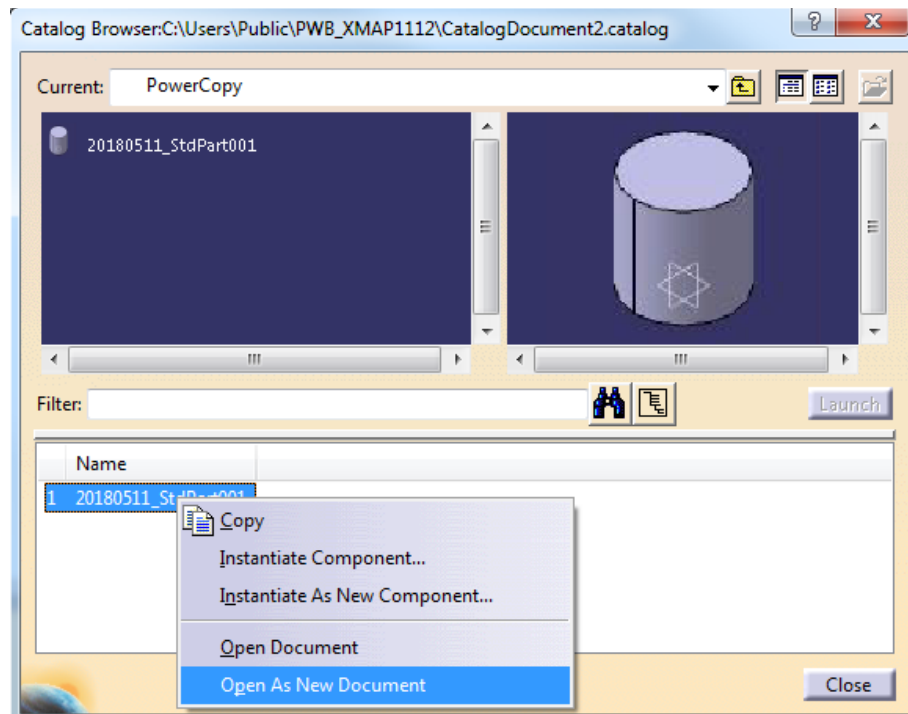

Picture 292: Open As New Document

Open Catalog for special Usage

There are some special CATIA functions like “Circuit Board Design” which need a Catalog as input.

To use this functionality, you have to open the Catalog from Aras Innovator into the CATIA session using “Open Catalog for Edit” before you start your special functionality. When you are asked for a Catalog during a function like “Circuit Board Design” you have to select the loaded Catalog document (see *Picture 293: Select Loaded document for Catalog*).

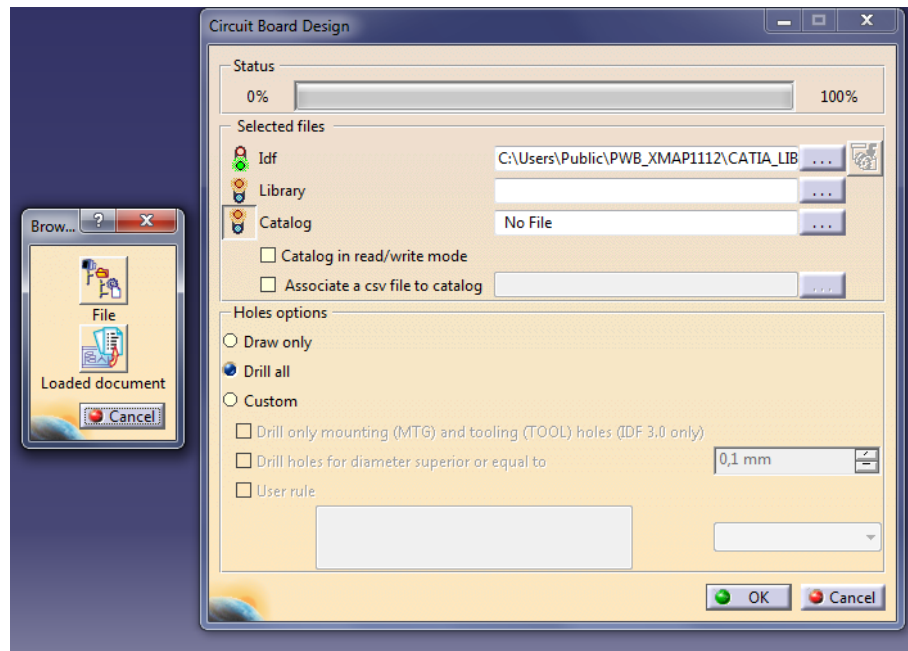

Picture 293: Select Loaded document for Catalog

Support floating Content in Catalog

By default, the Catalog points to a fixed Aras Innovator generation of the contained Aras Innovator CAD (Part). If this functionality is enabled, you will get the latest generation of the corresponding CAD (Part).

Configurable Catalog Keywords

By default, the identifying attributes (id or item_number when using floating Catalog content) are stored in the values of “PWB_CAD”, and in case of BOM-CATParts “PWB_PART”.

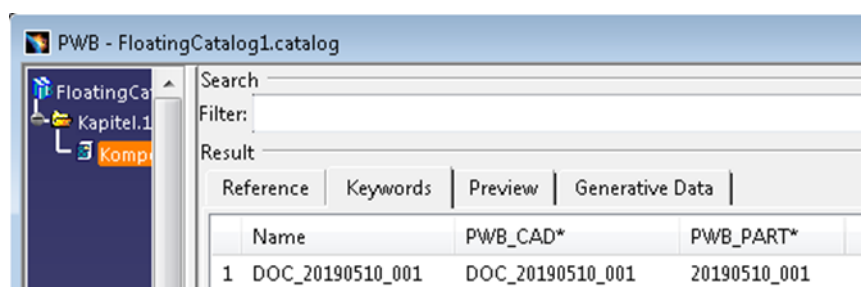

Picture 294: Configurable Catalog Keywords

It is possible to configure different Catalog keywords to store these values. In case of `useBomPartStructure = true`, if only BOM CATParts are used in the Catalog, it is also possible to remove the keyword for the CAD.

CATProcess File Support

CATProcess can be updated and loaded from Aras Innovator. If the CATProcess uses external references in the CATProcess Product List or in the CATProcess Resources List, the PDM Workbench creates a relation to the referenced items during update and downloads the referenced items during load.

Referenced CATProducts/CATParts must already exist in Aras Innovator. Update of the CATProcess will not update the referenced items. During update the user will get a warning if there are modifications in the referenced external structures.

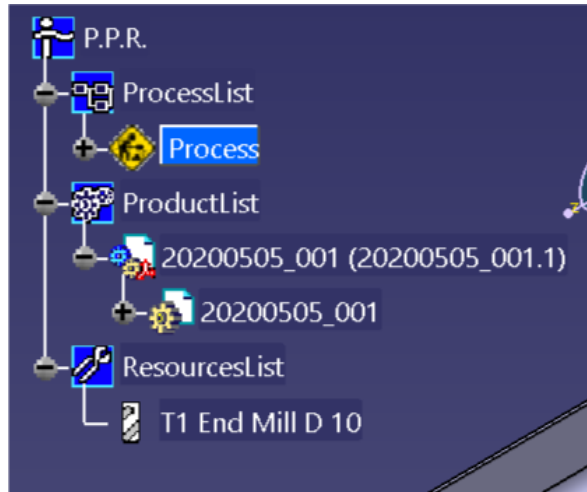

Picture 295: CATProcess with external referenced CATPart in the ProductList and internal Component in the ResourcesList

The related Aras Innovator structure would use the “/CAD Structure/CATProcessProduct (ProductList Sub-Structure)” relation between the CATProcess and the referenced CATPart. The internal Component in the ResourcesList is not exposed to Aras Innovator.

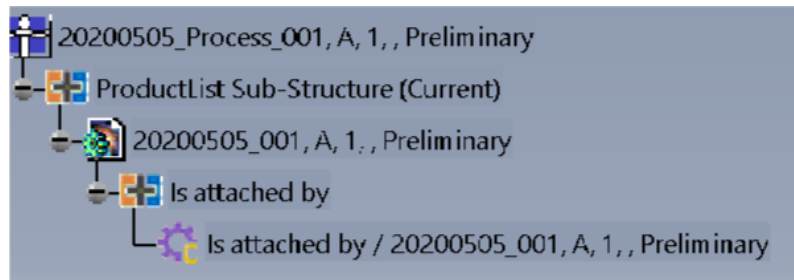

Picture 296: Aras Innovator structure of CATProcess with external referenced CATPart in the ProductList and internal Component in the ResourceList

It is also possible to have a CATProcess that references multiple external items in the ProductList and in the ResourcesList.

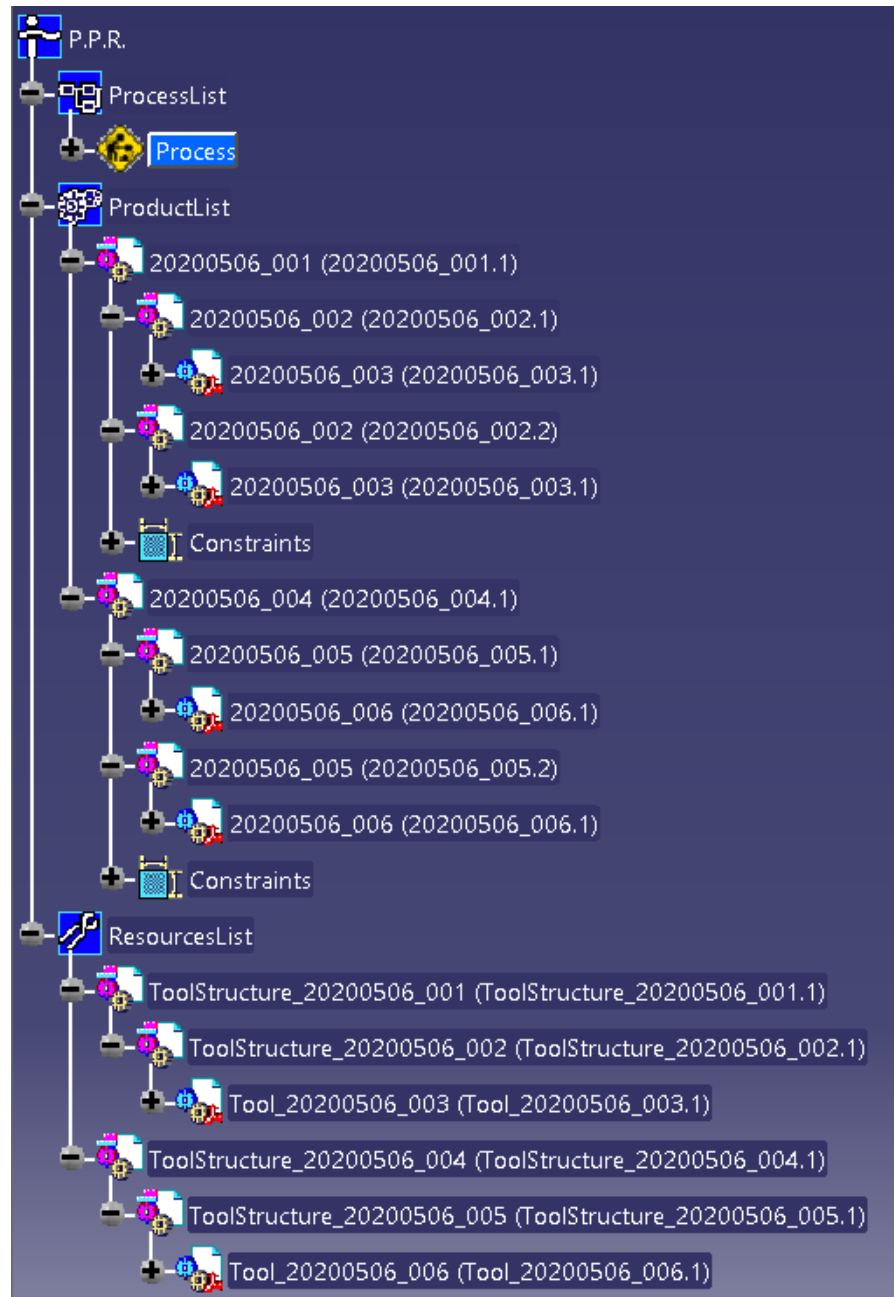

Picture 297: CATProcess with external referenced structures in the ProductList and in the ResourcesList

The related Aras Innovator structure would use the “/CAD Structure/CATProcessProduct (ProductList Sub-Structure)” relation and the “/CAD Structure/CATProcessResource (ResourcesList Sub-Structure)” relation to the directly referenced top-level CATProduct of the structures.

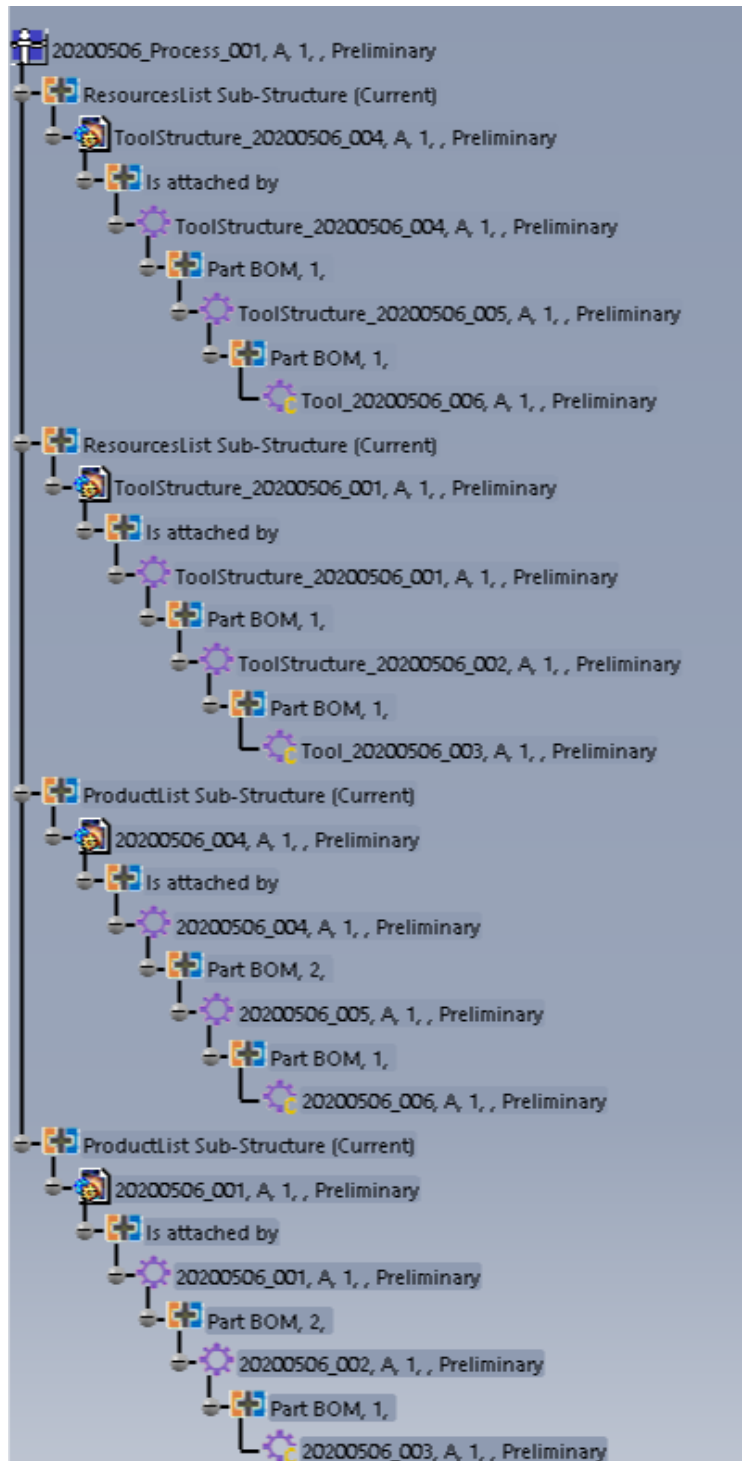

Picture 298: Aras structure of CATProcess with external referenced structures in the ProductList and in the ResourceList

If the user wants to modify the referenced structures alongside with the CATProcess it is possible to open the referenced CATProducts/CATParts in a new window. This can also be done by the PDM Workbench Options setting “Open linked Documents of CATProcess in own Window”:

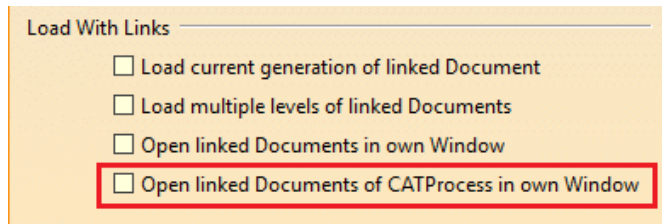

Picture 299: “PDM Workbench Options” dialog – “Open linked Document of CATProcess in own Window”

Configurable CATIA Component Support

It is possible to load and update CATProduct structures which contain embedded CATIA components. Depending on the Part Number prefix the embedded component nodes can either be “skipped”, that is, the node is treated as if it does not exist, but its child nodes are processed, or they can be “ignored”, that is, the node and all its child nodes are treated as if they do not exist.

In the following example the two instance nodes of the CATPart “NewPart3” are treated as if they were both directly under the CATProduct “NewProduct3”, and the two instance nodes of the CATPart “NewPart4” are completely ignored, that is, the structure is treated as if they do not exist (see *Picture 300: Embedded CATIA component nodes*).

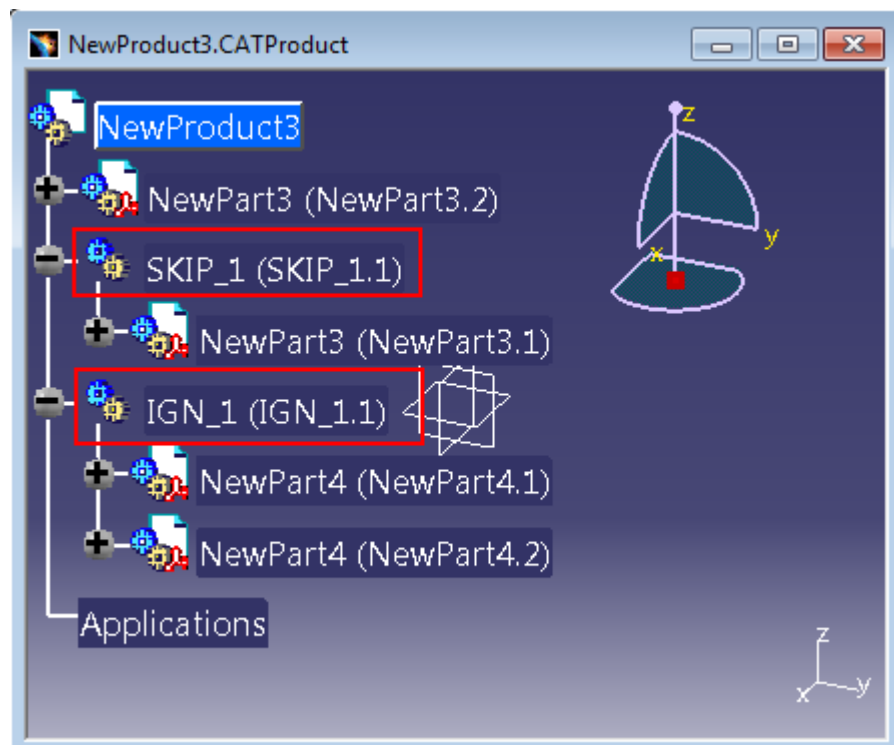

Picture 300: Embedded CATIA component nodes

Electrical/Tubing Support

With this functionality it is possible to use functions like “Electrical Harness”, “Electrical Wire Routing”, “Piping Design”, “Tubing Design”, ... of the CATIA “Equipment & Systems Engineering” section.

The functions of the “Equipment & Systems Engineering” section often create embedded leaf components (without files) of special types like “ElecWireLight” (see *Picture 301: Example document containing electrical components*).

By default, PDM Workbench does not support embedded components in the CATIA structure, because an embedded component does not have an own file, but is stored in the parent CATProduct. Therefore, such a component cannot be reused under a different parent.

There is no need to map these leaf components to PDM documents/parts. The parent CATProduct of the embedded leaf components holds all information of the embedded leaf components.

This functionality allows two ways to use such embedded leaf components:

- a) Allow leaf components of any type in the CATIA structure. Leaf components are not mapped to PDM documents/parts
- b) Configure special types of like “ElecWireLight” to be allowed in the CATIA structure. Components of the configured types are not mapped to PDM documents/parts

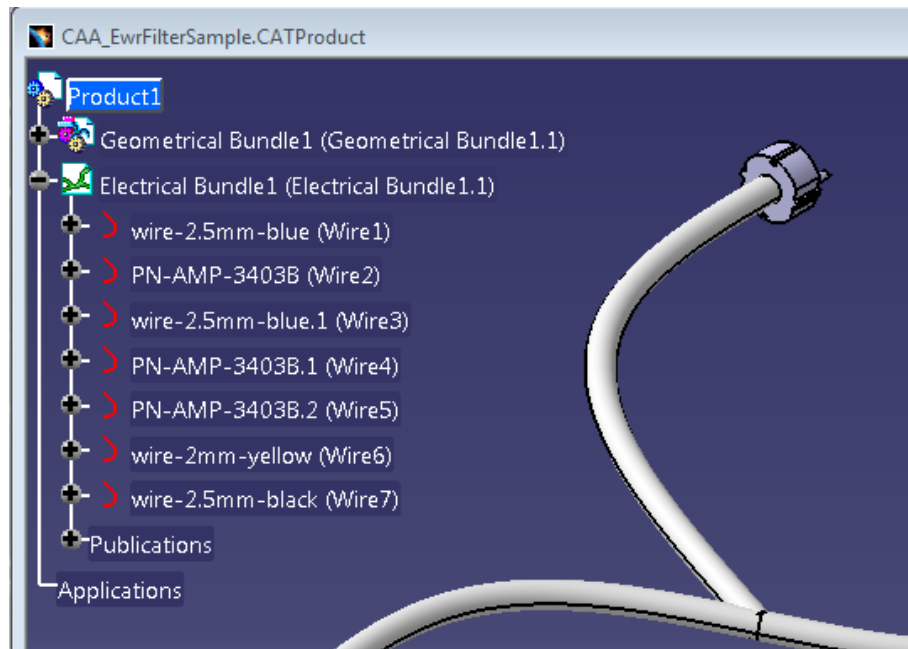

Picture 301: Example document containing electrical components

To get the type of a component just use the “Update” functionality. If there is an unsupported component, a message box shows the type of the first unsupported component (see *Picture 302: Warning about unsupported CATIA component node*).

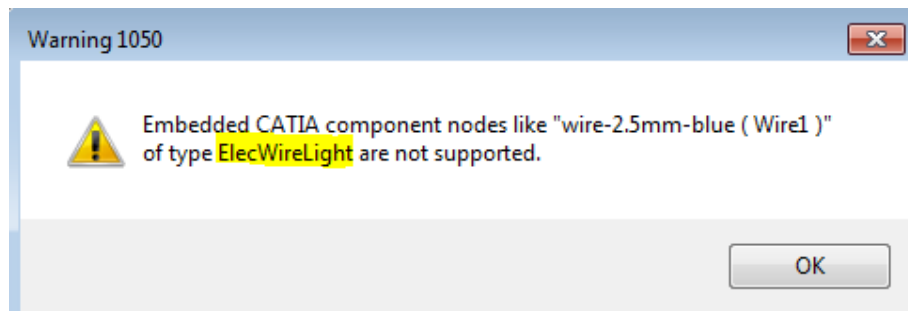

Picture 302: Warning about unsupported CATIA component node

Additional Rep Types

It is possible to load additional 3D rep types in addition to e.g. “CAD_3D” in the CATProduct structure at the same time (see *Picture 303: Two CATParts with different rep types related to the same part loaded at the same time*).

This is only possible when the different 3D rep type CATParts are defined as non-BOM CAD Documents. BOM-relevant CAD Documents are the CAD items that are related directly to the Part item with the “Part CAD” relation. Non-BOM CAD Documents are the “CAD Structure/Structure” child nodes of the BOM-relevant CAD Documents:

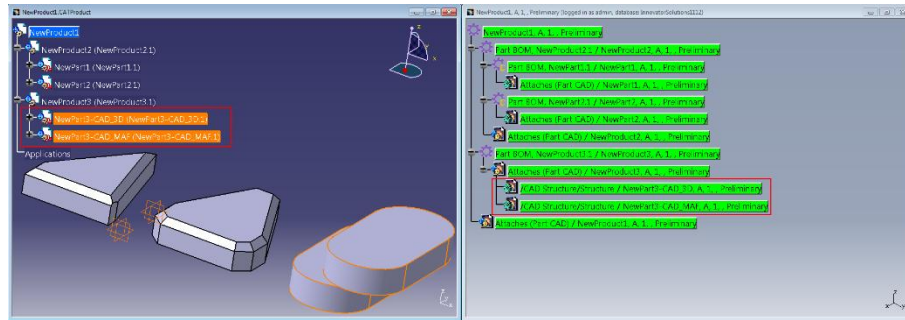

Picture 303: Two CATParts with different rep types related to the same part loaded at the same time

If the rep type filter functionality is configured in the Schema file a new command is available in the PDM Workbench toolbar (see *Picture 304: Filter Representation Type command*).



Picture 304: Filter Representation Type command

This command opens the selection of the representation types to be loaded. Selection changes are persistent until CATIA is closed (see *Picture 305: Select non-BOM Representation types to be loaded*).

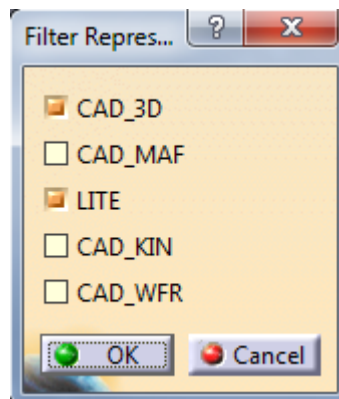

Picture 305: Select non-BOM Representation types to be loaded

Support generic Shape Representations

Depending on the CATIA installation it is possible to add a geometry file of a type like CATShape, jt, pkg, wrl, STL or others as a representation to a Component. The present functionality supports to store these additional geometry files in Aras Innovator. The extra geometry files are treated as read-only files, just like CATIA V4 model files.

It is possible to configure up to five additional types to be supported.

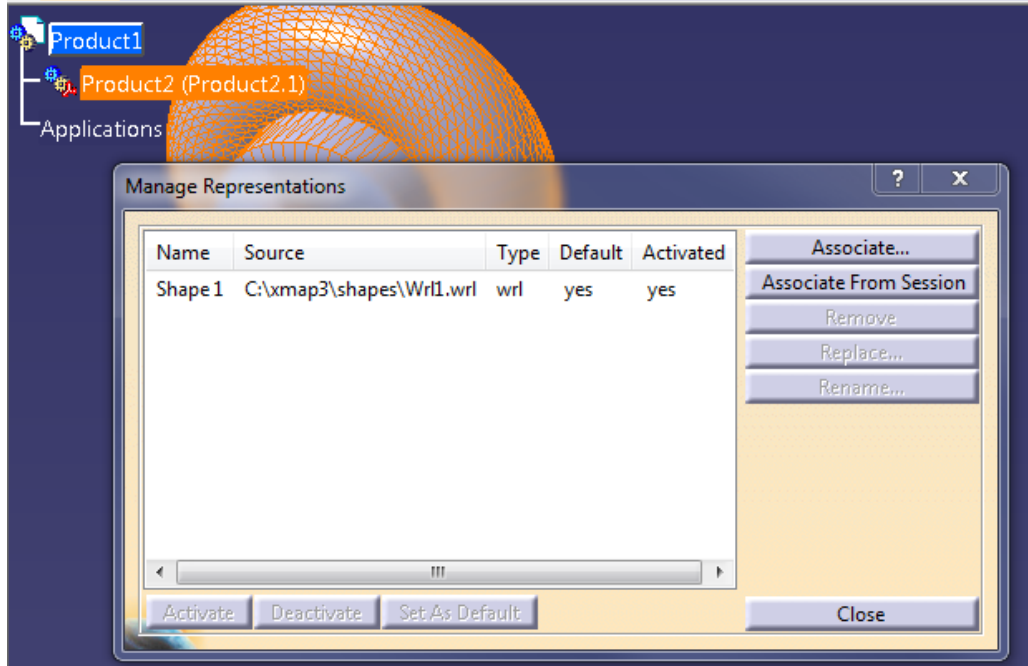

Picture 306: Manage Representations

CATIA Documents are set to read-only if corresponding PDM Node is not modifiable

Loading a structure sets the corresponding CATIA files to read-only (see *Picture 307: Save Management*).

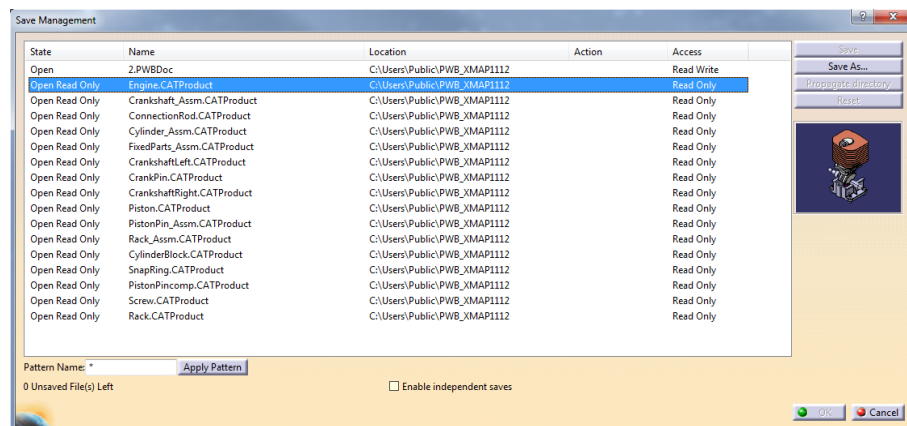

Picture 307: Save Management

Check whether CATIA Structure is valid before Update

Before the structure will be created in the PDM system it will be checked if it is valid (see *Picture 308: Check if CATIA structure is valid*).

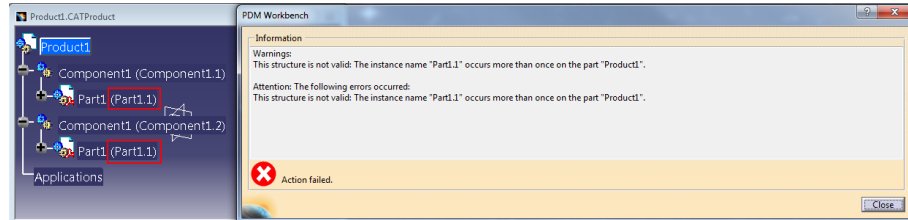

Picture 308: Check if CATIA structure is valid

Thumbnails

In the “Properties” dialog for part and drawing documents a thumbnail will be shown (see *Picture 309: CAD Document properties in Aras Innovator*).

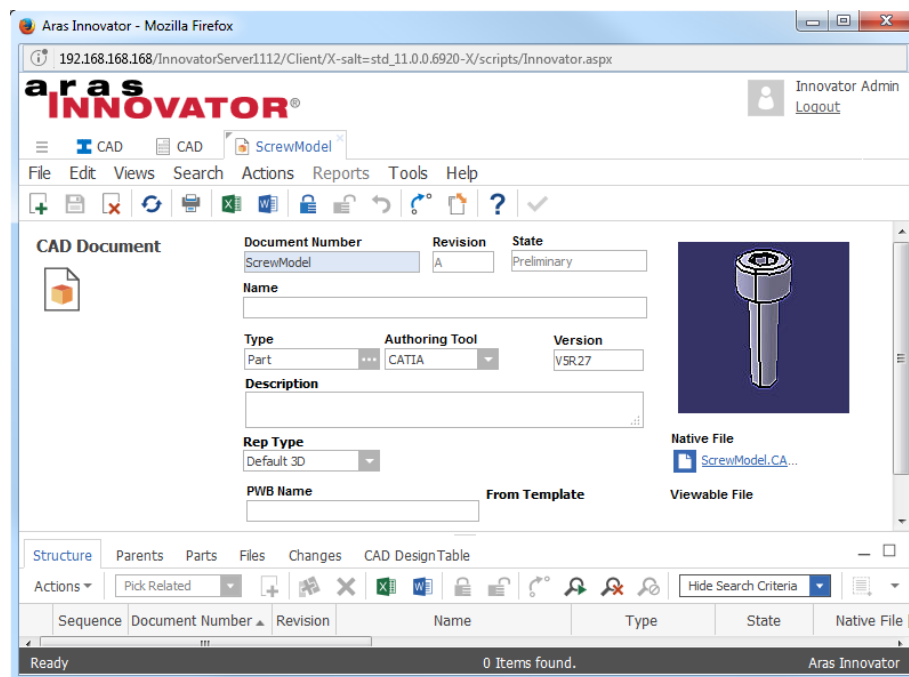

Picture 309: CAD Document properties in Aras Innovator

Link Management

When designing, the user can create many types of links between CATIA features or between a CATIA feature and a foreign object. Some of these links are presented to the user in the “Edit Links” command, others are not shown in the CATIA UI.

The information about the CATIA links, which are pointing from an object in one document to an object in another document (“external link”), can be retrieved and transferred to Aras Innovator.

Previous PDM Workbench releases supported the transfer of CATIA links between a CATDrawing and a CATProduct or CATPart (“Drawing” link in Aras Innovator) and between a CATPart and a CATPart (“Reference” link in Aras Innovator). Furthermore, regular product structure links and Design Table links were supported. This is still the default behaviour with this PDM Workbench release.

The PDM Workbench provides the capability to detect and transfer all CATIA external link types as they are provided and grouped by CATIA.

The regular product structure links and the Design Table links are managed, too.

Eight additional link types are supported now (with the PWB Configuration item setting UseAllCatiaLinkTypes = true) and the corresponding Aras Innovator CAD Structure sub-classes (classification property, default label “Dependency”) are named like the internal CATIA links:

- Contextual
- Reference (Original CATIA link type “Design”)
- Drawing (Original CATIA link type “Downstream”)
- IsComposedOf
- Product
- Reference
- Result
- RuleBase

Depending on the context, CATIA product links are created as two different classifications:

- *Structure* (regular product structure links from a CATProduct to another document)
- *Product* (other CATIA Product links not pointing from a CATProduct, but e.g. from a CATPart to a CATShape or cgr)

The links are created in Aras Innovator, if both the pointed and the pointing document are known and the pointed document is stored first.

The link information can be displayed in the regular Aras Innovator relationship grid of an Aras Innovator CAD Document and in the CATIA PWB PDM Structure window, for one level, or for multiple levels:

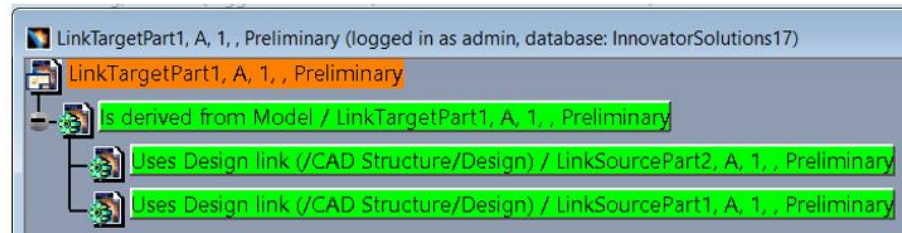
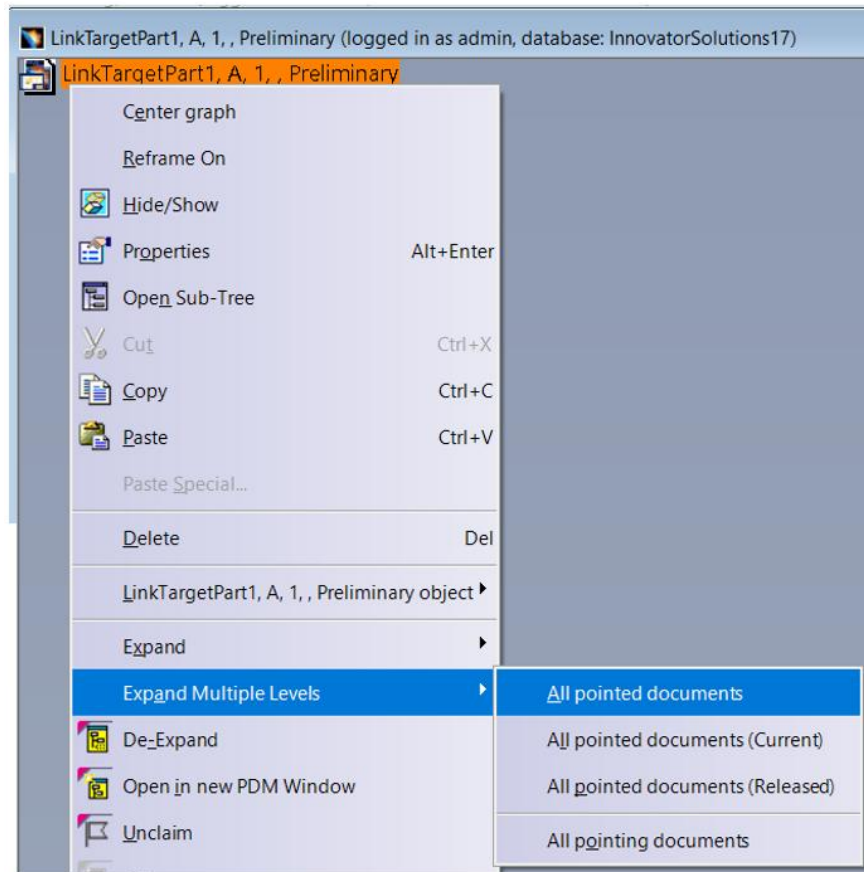

Picture 310: Expand → All pointed documents

Basic Drawing Link Support

When a CATDrawing CAD Document is created, you can decide which of the related 3D geometry documents is defined to be the main source geometry document. A link of the type “/CAD Structure/Drawing” is created from the CATDrawing to that 3D document when the drawing document is created.

If the source 3D geometry documents of the drawing are loaded from PDM and the PDM Workbench session contains information about the corresponding CAD Documents in PDM then the linked 3D geometry document will be selected in the “Main 3D File” combo box if a single 3D document is linked (see *Picture 311: Creating a CATDrawing document with a link to 3D geometry*).

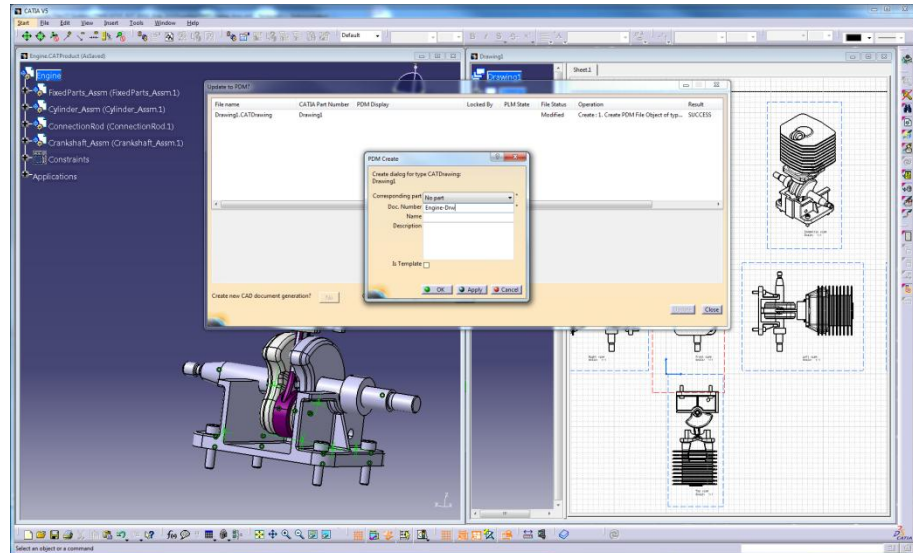

Picture 311: Creating a CATDrawing document with a link to 3D geometry

When you create the drawing CAD Document a PDM relation of the type “/CAD Structure/Drawing” will be created in the PDM system after the CATDrawing PDM document has been created (see *Picture 312: PDM message about created drawing link*).

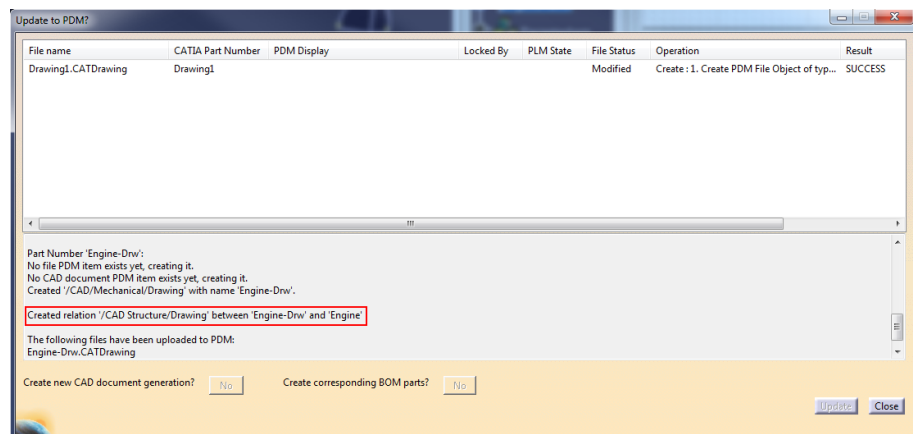

Picture 312: PDM message about created drawing link

You can expand to this document by selecting the CATDrawing object. Then click the right mouse button and select *Expand*→*Is derived from Model* (see *Picture 313: Expanding newly created drawing link*).

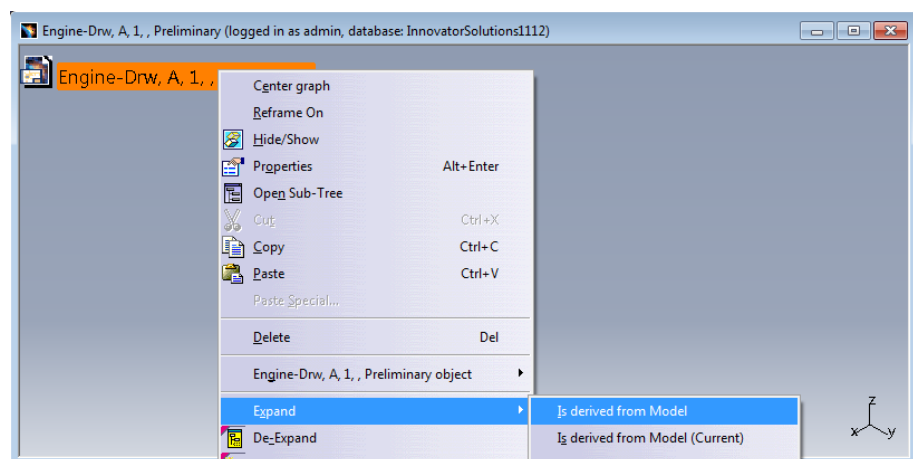

Picture 313: Expanding newly created drawing link

The document will be displayed in the window (see *Picture 314: Displaying newly created drawing link*).

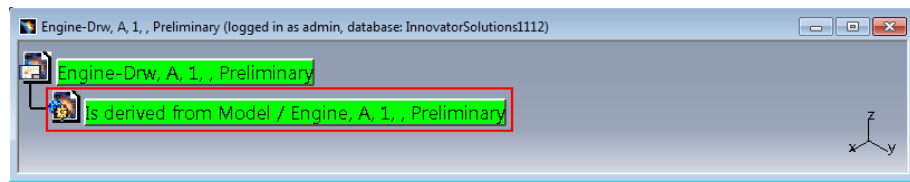

Picture 314: Displaying newly created drawing link

If you create a drawing with links to more than one 3D geometry file then both linked documents will be displayed in the window (see *Picture 315: Displaying all created drawing links*).

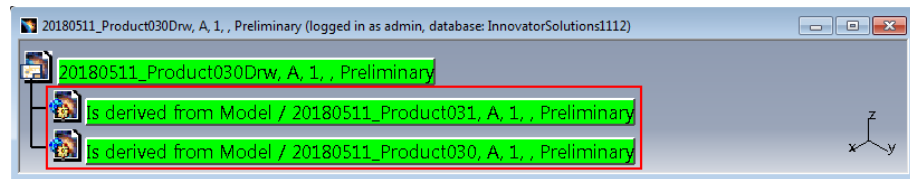

Picture 315: Displaying all created drawing links

Drawing links are not updated or deleted when a CATDrawing is updated, even if links are created or removed in CATIA. The related primary 3D document is not supposed to change during the lifetime of the CATDrawing.

CATDrawing: Loading referenced Data as “Current”

It is possible to load the 3D data (CATParts or CATProduct structures) which are referenced by a CATDrawing as “Current” instead of “As Saved”, which is the default.

In this example, the CATDrawing “Engine-Drw” was generated by the generation 1 of the CATProduct structure “Engine”, but a second generation of the CATProduct structure has been created (see *Picture 316: “As Saved” drawing link*).

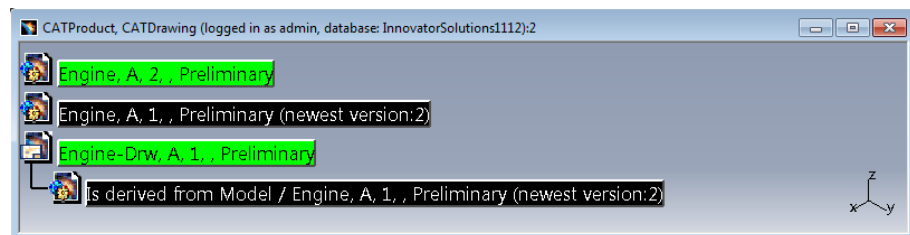

Picture 316: “As Saved” drawing link

The drawing relation can also be expanded as “Current” (see *Picture 317: “Current” drawing relation*).

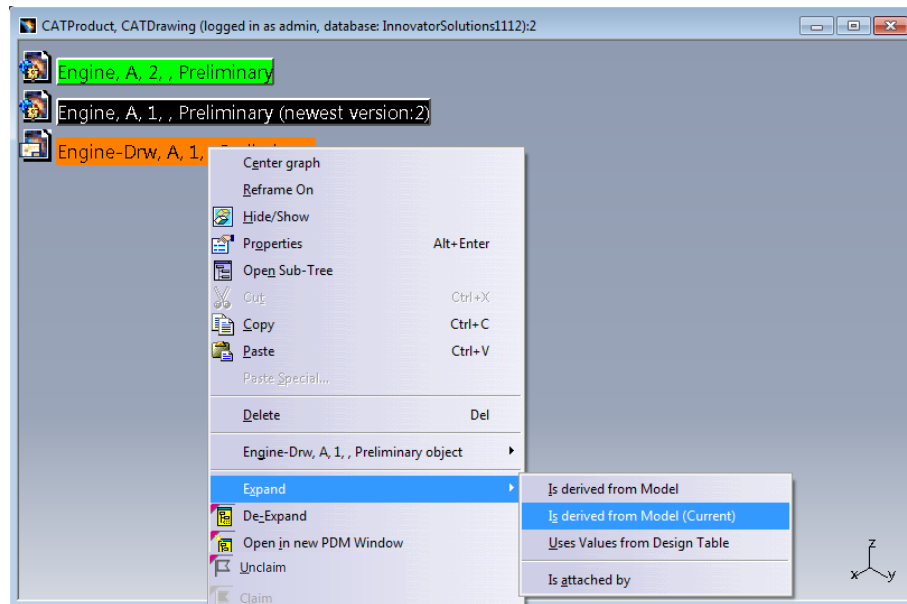

Picture 317: “Current” drawing relation

“Open with related 3D files” loads the related 3D documents as they are stored in the database (see *Picture 318: Loading “As Saved”*).

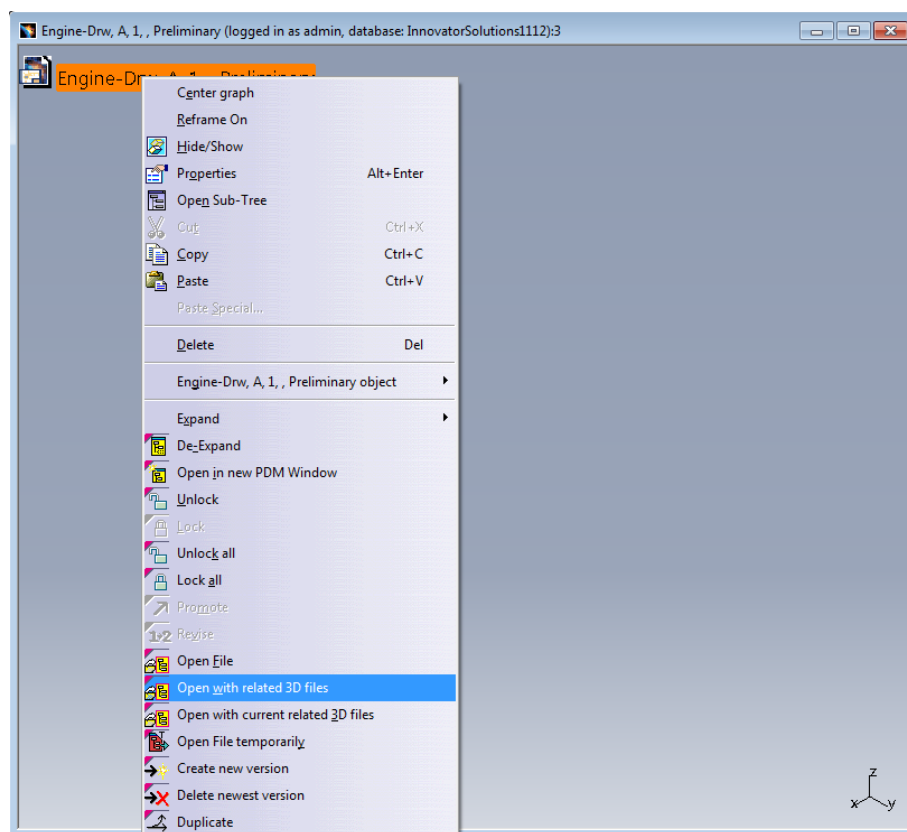

Picture 318: Loading “As Saved”

This is the generation 1 of the CATProduct structure. The CATDrawing does not have to be refreshed because it was saved with this 3D geometry (see *Picture 319: Generation 1 of the CATProduct structure*).

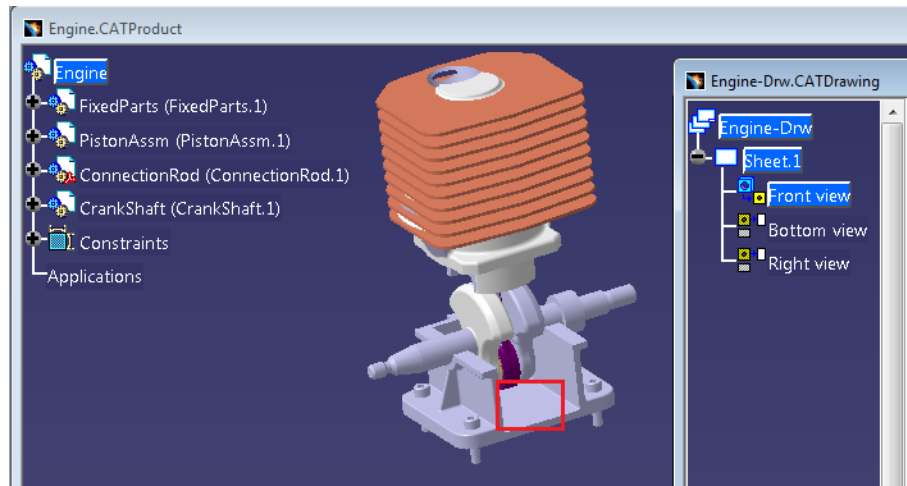

Picture 319: Generation 1 of the CATProduct structure

“Open with current related 3D files” loads the newest generation of the related 3D documents (see *Picture 320: Loading “Current”*).

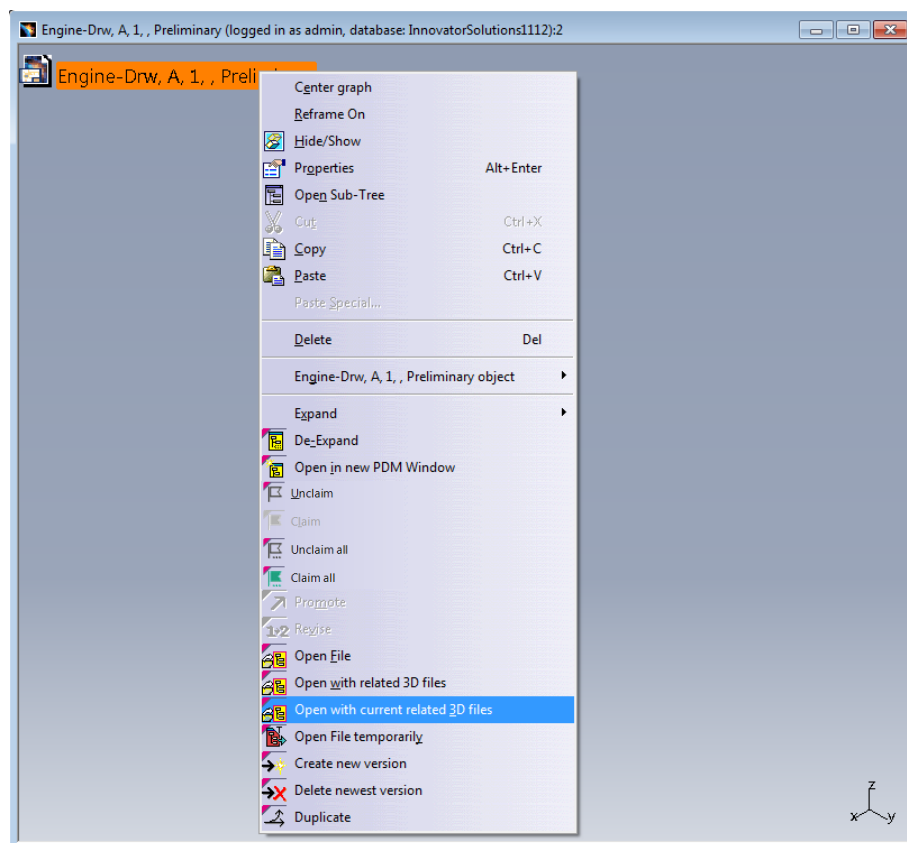

Picture 320: Loading “Current”

This is the generation 2 of the CATProduct structure. The CATDrawing has to be refreshed because it was saved with a previous generation of the 3D geometry (see *Picture 321: Generation 2 of the CATProduct structure*).

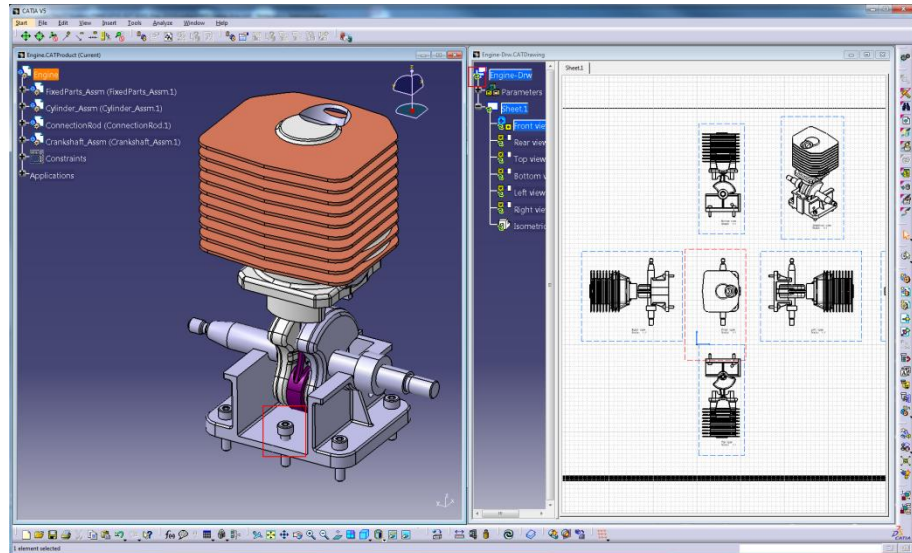

Picture 321: Generation 2 of the CATProduct structure

This functionality can also be used from the “PDM Query” dialog (see *Picture 322: Actions “Open with related 3D files / Open with current related 3D files”*).

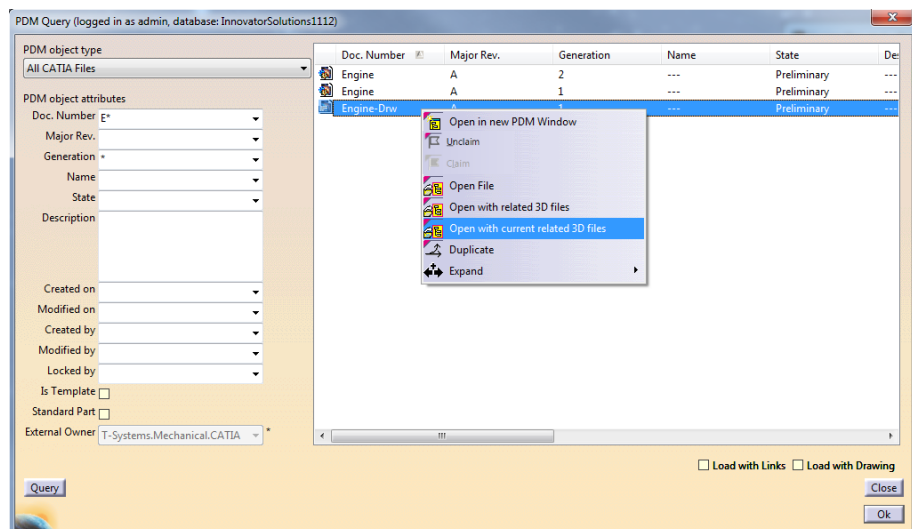

Picture 322: Actions “Open with related 3D files / Open with current related 3D files” in “PDM Query” dialog

Basic Multi-Model Link Support

When a CATPart CAD Document is created or updated the geometry links of imported 3D geometry will be updated as PDM links of the type “/CAD Structure/Reference”. Both reference links and instance links are supported.

If the functionality is switched on, when a CATPart contains geometry links, PDM relations of the type “/CAD Structure/Reference” which correspond to these links are created (see *Picture 323: Information when reference links are created*).

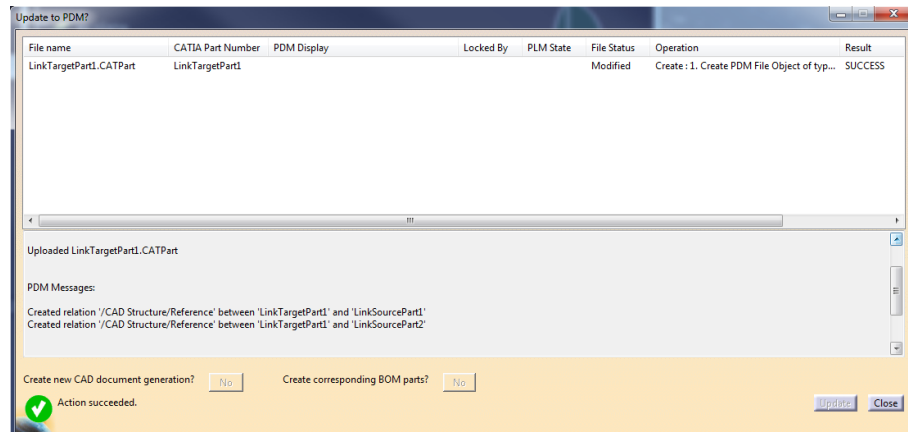

Picture 323: Information when reference links are created

If the links are removed from the CATIA file then the corresponding PDM relations are deleted (see *Picture 324: Information when reference links are deleted*).

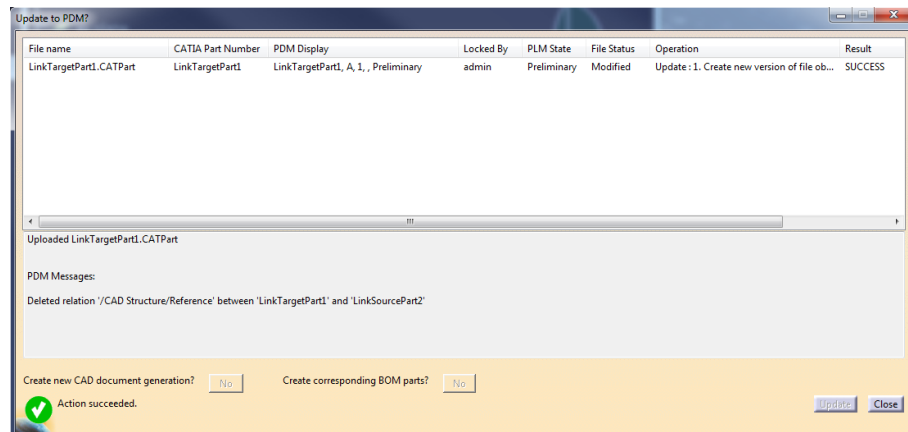

Picture 324: Information when reference links are deleted

The created links can be expanded. Select the document and click the right mouse button. Select *Expand* → *Uses Geometry from* (see *Picture 325: Expanding geometry links*).

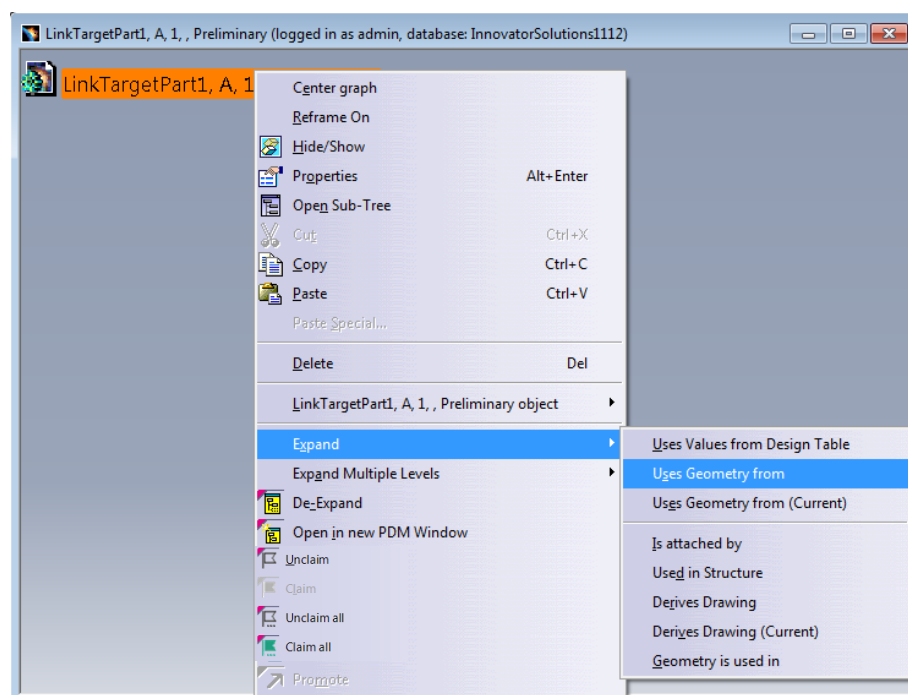

Picture 325: Expanding geometry links

The document will be displayed in the window (see *Picture 326: Geometry link expansion result*).

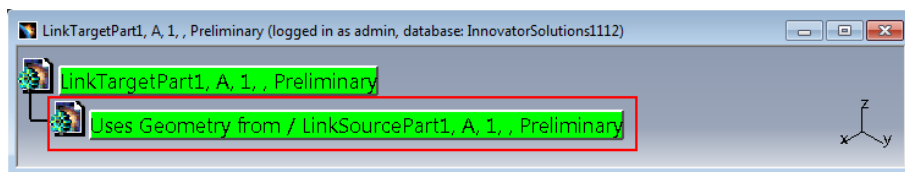

Picture 326: Geometry link expansion result

Support for Relating a new CATIA File to an existing Part

The currently active CATIA document (only CATParts or CATDrawings) can be related to an existing BOM part item. If there is already a corresponding CAD Document related to the part the document's file can be overwritten.

The CATPart or CATDrawing file which is the currently active document in the CATIA session can be related to a part in the query result list by the context menu action "Relate active File to Part" (see *Picture 327: Action "Relate active File to Part"*).

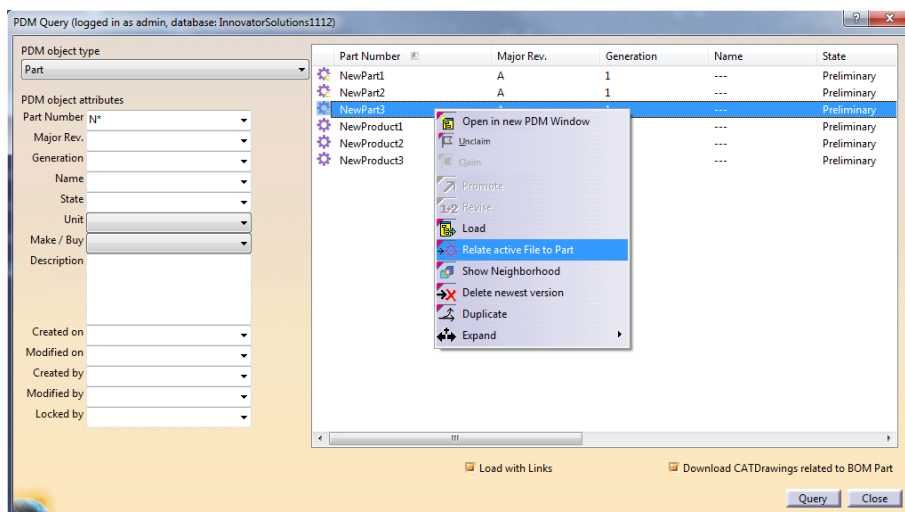

Picture 327: Action "Relate active File to Part"

If there is already a CAD Document related to the part you are asked whether you want to overwrite the corresponding file (see *Picture 328: Confirm the "Relate active File to Part" action*).

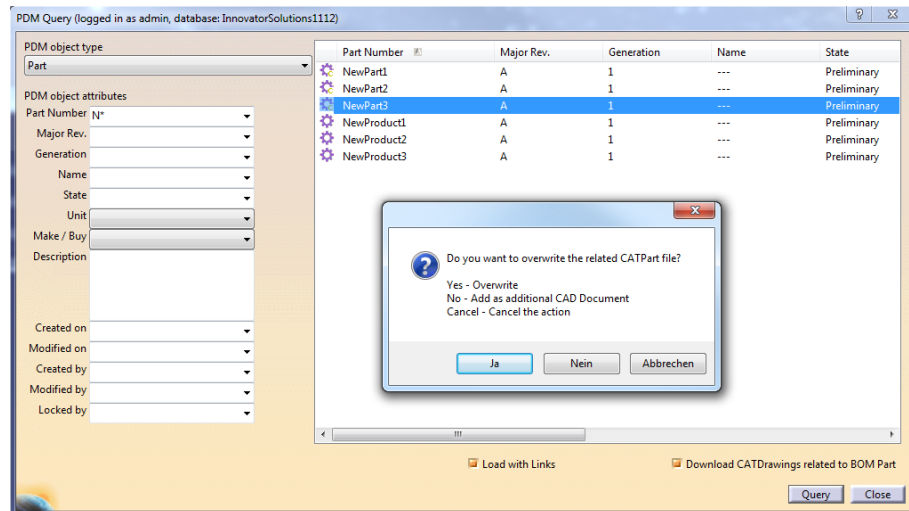

Picture 328: Confirm the “Relate active File to Part” action – Overwrite

The file can only be overwritten if the BOM part item is not used in a BOM Part Structure Data Model (see *Picture 329: Information prompt for “Relate active File to Part” action*).

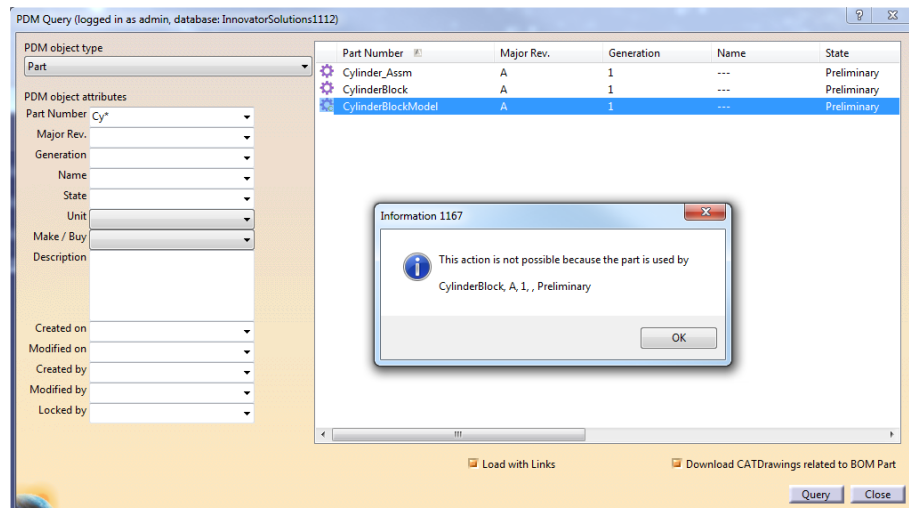

Picture 329: Information prompt for “Relate active File to Part” action

Delete Relation

PDM relations can be deleted in the PDM Structure window with a single context menu action, even if the PDM relations are not displayed in the structure.

The “Delete relation” action deletes the expanded parent relation of the selected PDM structure node in the PDM Structure window (see *Picture 330: Action “Delete relation”*).

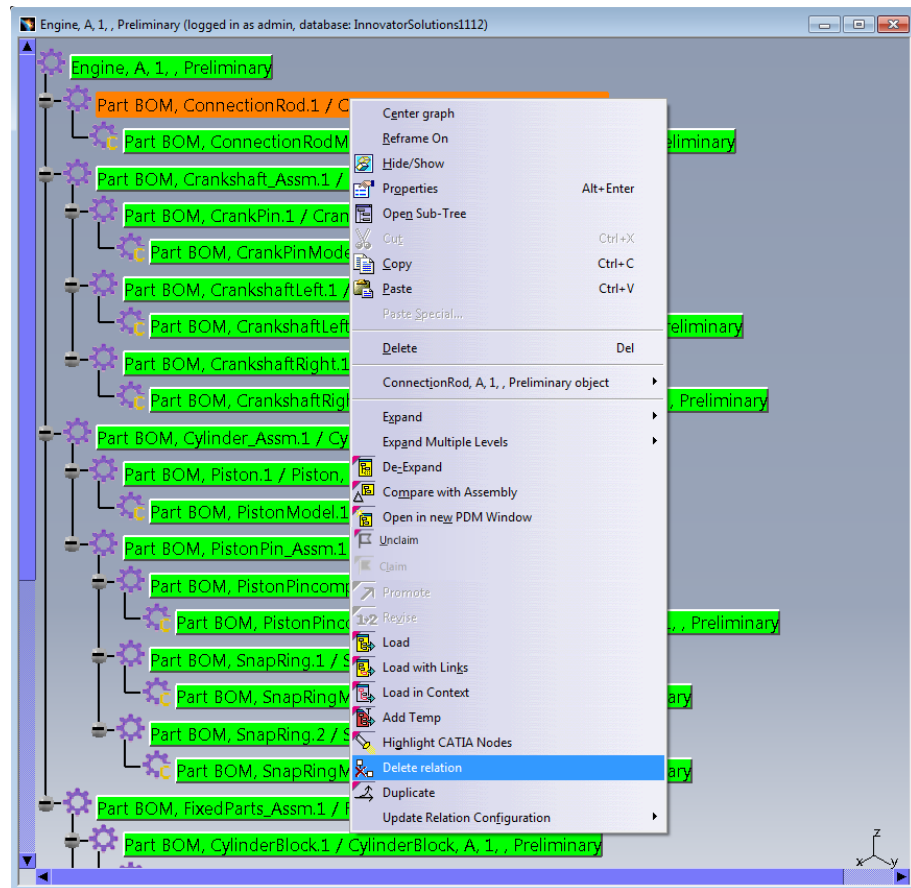

Picture 330: Action “Delete relation”

Delete Relations of non-loaded Instances

Normally you can only delete relations during “Update” if the relation was loaded by the PDM Workbench. With this functionality it is possible to delete relations which are not loaded.

It is possible to use this functionality in the BOM Part Structure Data Model and in the CAD Document Structure Data Model.

Use Case

When your complete Assembly in Aras Innovator looks like this ...

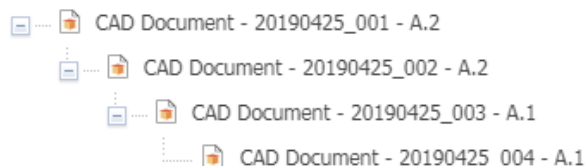

Picture 331: Assembly in Aras Innovator

... but in CATIA you don’t expand all relations before load (The missing structure could also be filtered out by a configuration) ...

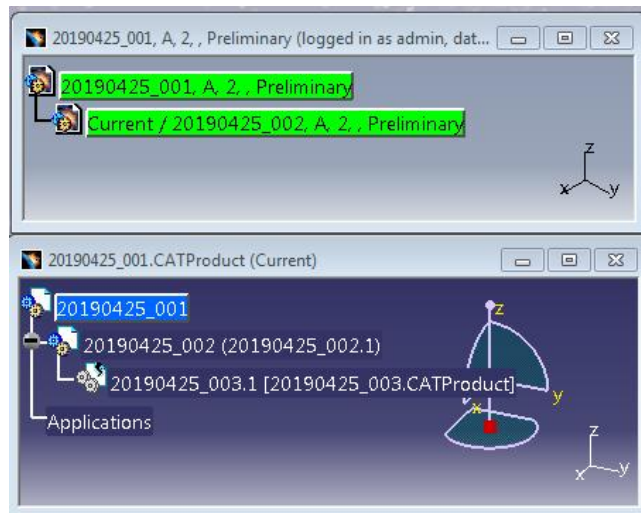

Picture 332: Structure in PDM Workbench and CATIA window

... then you delete the broken link in CATIA.

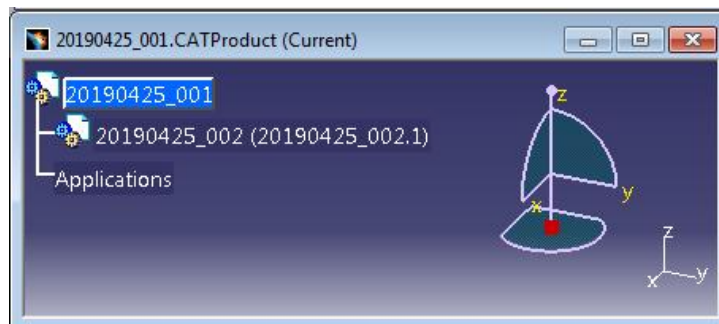

Picture 333: Delete broken link

During “Update” the relation of the broken link in Aras Innovator is deleted if existing and possible.

```
Part Number '20190425_002':
Removing instance from CAD Structure relation.
Deleted instance '20190425_003.1' of CAD Structure relation, updated quantity to '0'.
Removed CAD Structure relation.
```

Picture 334: Delete instance relation

Bounding Box Management / “Show Neighbor” Functionality

The PDM Workbench can be set up such that the bounding box values of the updated CATParts are saved in the PDM CAD Document items. If that is done it is possible to use these values to find the neighbor geometry documents whose bounding boxes overlap with the bounding box of the selected CATPart.

As an example, you want to find out which bounding boxes of other CATParts in the structure “Engine.CATProduct” overlap with the bounding box of the CATPart “CrankShaftLeft.CATPart” (see *Picture 335: CATPart geometry in the context of a CATProduct structure*).

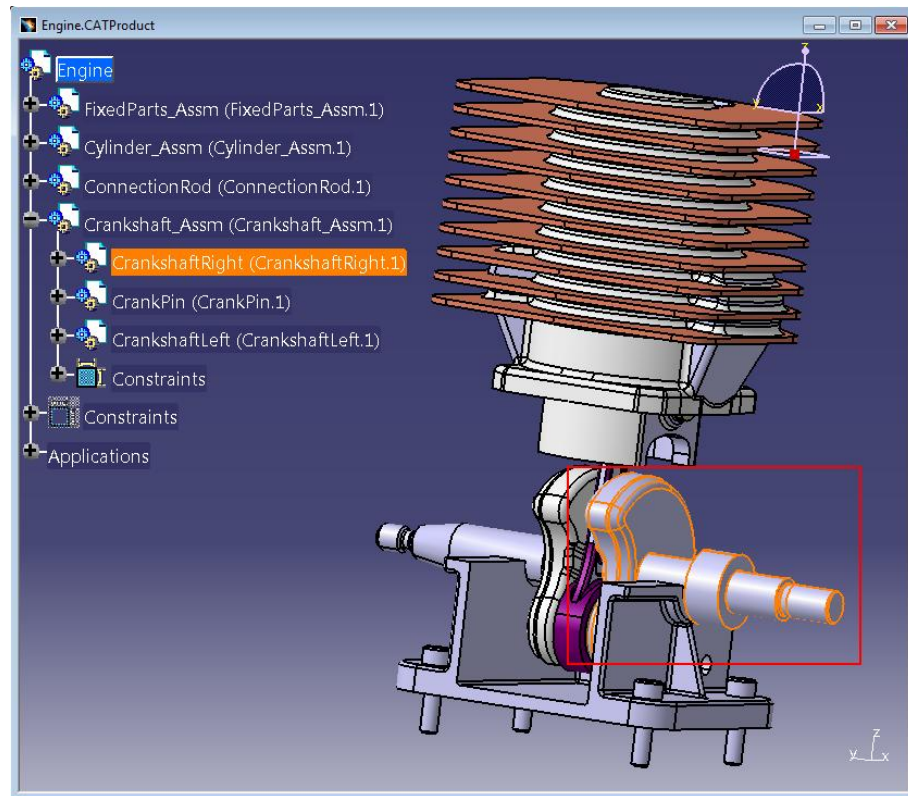

Picture 335: CATPart geometry in the context of a CATProduct structure

This is the corresponding CAD structure in PDM (see *Picture 336: CATPart document in CAD structure*).



Picture 336: CATPart document in CAD structure

In the first step you search for the CATPart document which you want the neighborhood of. Then you click on the context menu “Show Neighborhood” (see *Picture 337: Action “Show Neighborhood”*).

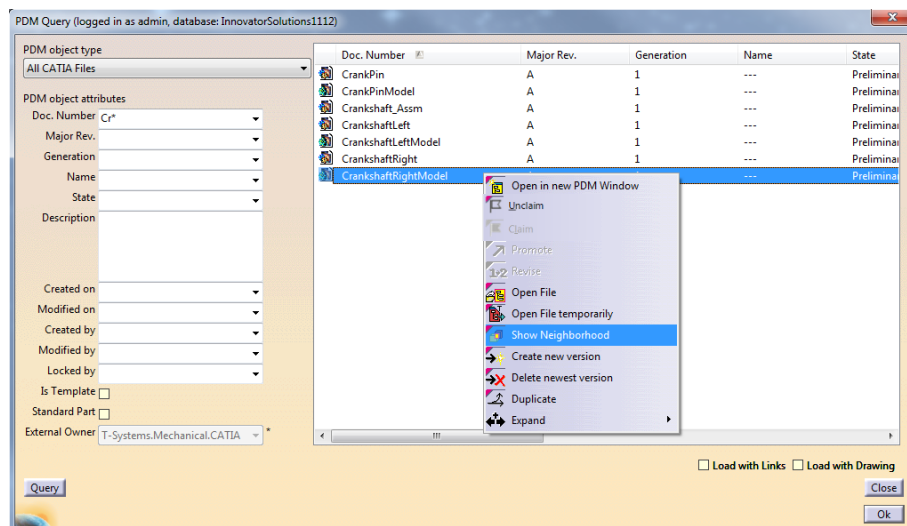

Picture 337: Action “Show Neighborhood”

A query window appears where you can search for a CATProduct document (or an Assembly part in the BOM Part Structure Data Model) (see *Picture 338: “PDM Query” dialog for context Assembly node*).

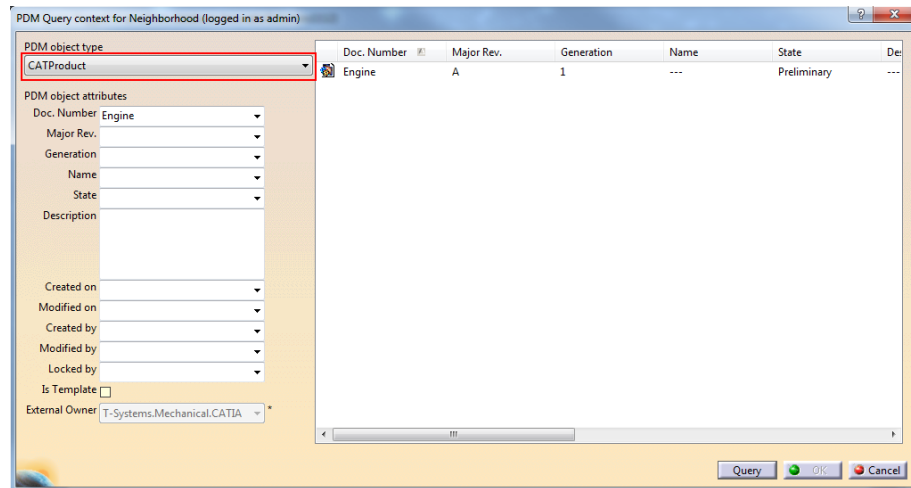

Picture 338: “PDM Query” dialog for context Assembly node

The structure, of which the selected CATProduct is the root document, has to contain the previously selected CATPart.

When you double-click on the selected CATProduct, a specific multi-level structure expand is performed which only returns the parts of the structure where the CATPart’s bounding boxes overlap with the bounding box of the previously selected CATPart. This is a sub-set of the complete structure (see *Picture 339: Reduced PDM structure containing only neighbor models*).



Picture 339: Reduced PDM structure containing only neighbor models

When this structure is loaded to CATIA you can see the geometry where the bounding boxes overlap with the originally selected CATPart’s bounding box (see *Picture 340: Reduced structure loaded to CATIA*).

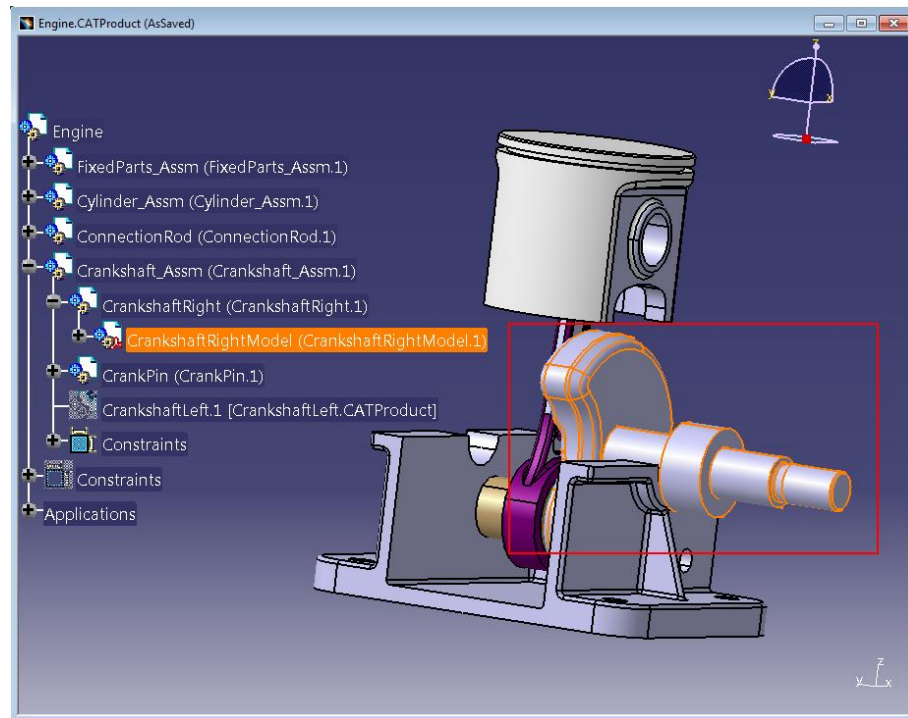

Picture 340: Reduced structure loaded to CATIA

If the selected structure does not contain the selected CATPart you will receive a warning message (see *Picture 341: The selected structure does not contain the selected CATPart*).

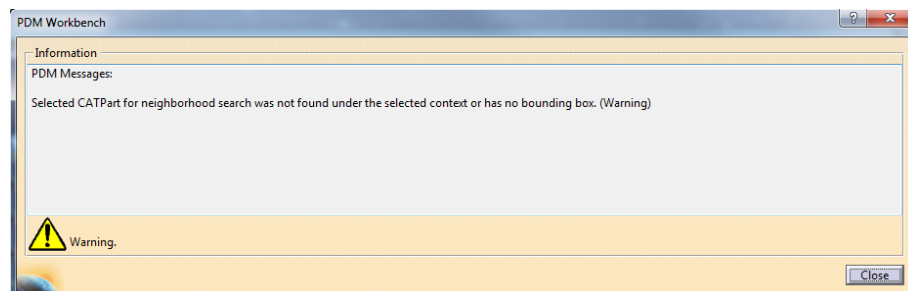

Picture 341: The selected structure does not contain the selected CATPart

Automatic Part Creation in CAD Document Structure Data Model

It is possible to automatically create BOM part items when a new CAD Document is created.

You can define whether for new CATIA files, where new CAD Document items will be created in the “Update” process, new BOM part items should also be created (see *Picture 342: “Create corresponding BOM parts” check box*).

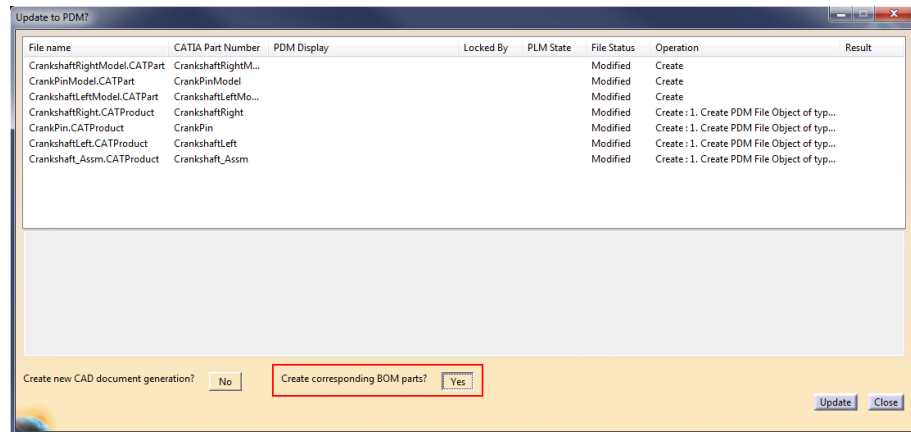

Picture 342: “Create corresponding BOM parts” check box

After the “Update” process has completed the Part items are created in PDM, and the corresponding CAD Documents are related to the parts with the “Part CAD” relation.

Expanding the Part CAD relation shows the Part items in the PDM Structure window (see *Picture 343: CAD structure with related Part items*).

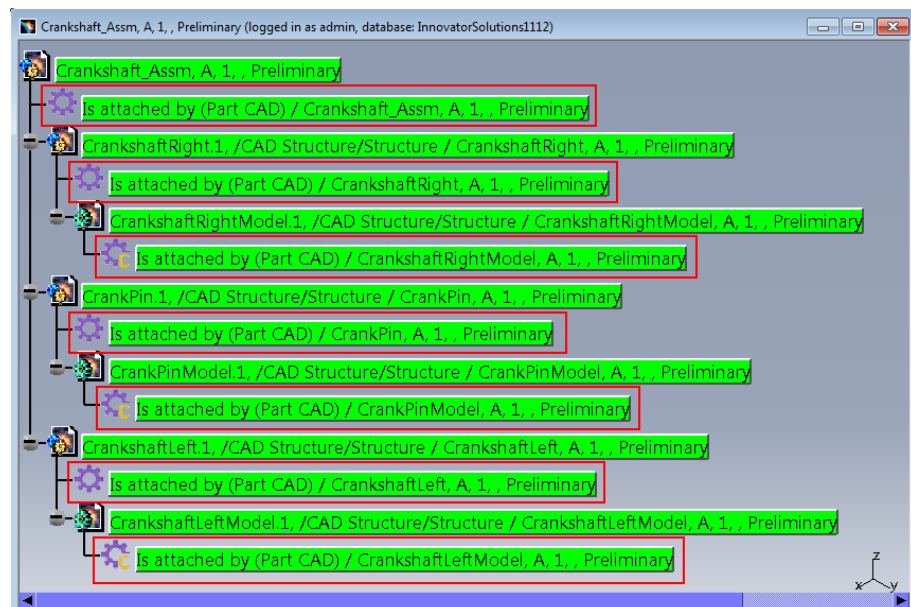

Picture 343: CAD structure with related Part items

Support for the new CAD Structure Instance Handling introduced in Aras Innovator 9.4 and 10.0

A new relation with the name “CAD Instance” has been introduced, which contains instance information for “CAD Structure” relations.

One visible difference in the usage is that the CAD Structure relations become multi-quantity relations, that is, there is only one relation for any number instances on a CATProduct.

Here is an example with four instances of a child part (see *Picture 344: Structure with four instances*).

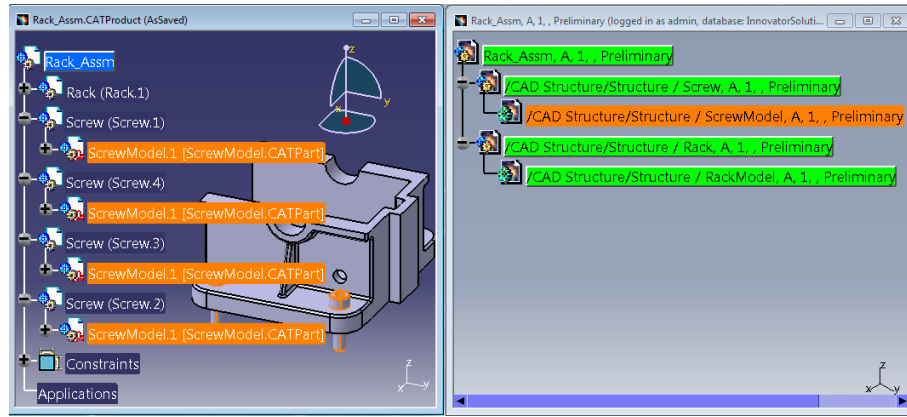

Picture 344: Structure with four instances

The four instances are stored in one CAD Structure relation which contains four CAD Instance relations (see *Picture 345: One CAD structure relation for each used CAD Document*).

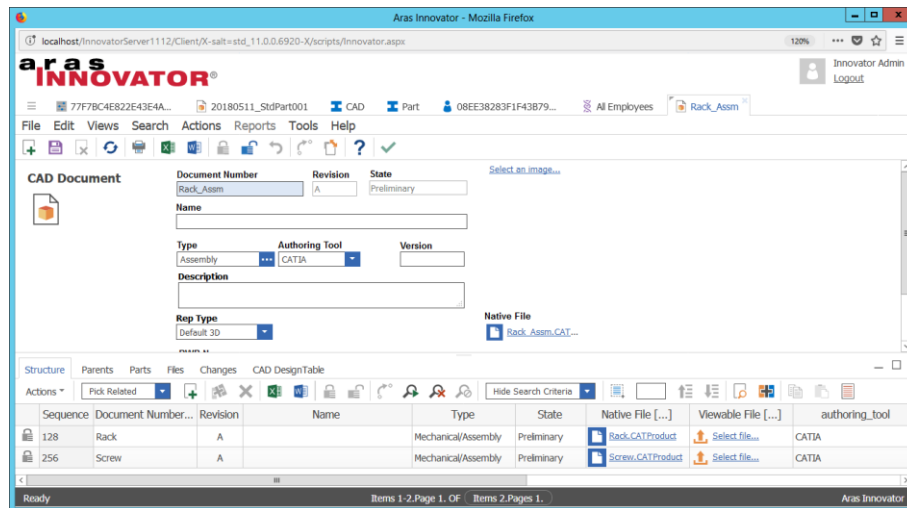

Picture 345: One CAD structure relation for each used CAD Document

The CATIA instance information is stored in the CAD Instance relations (see *Picture 346: CAD Instance information*).

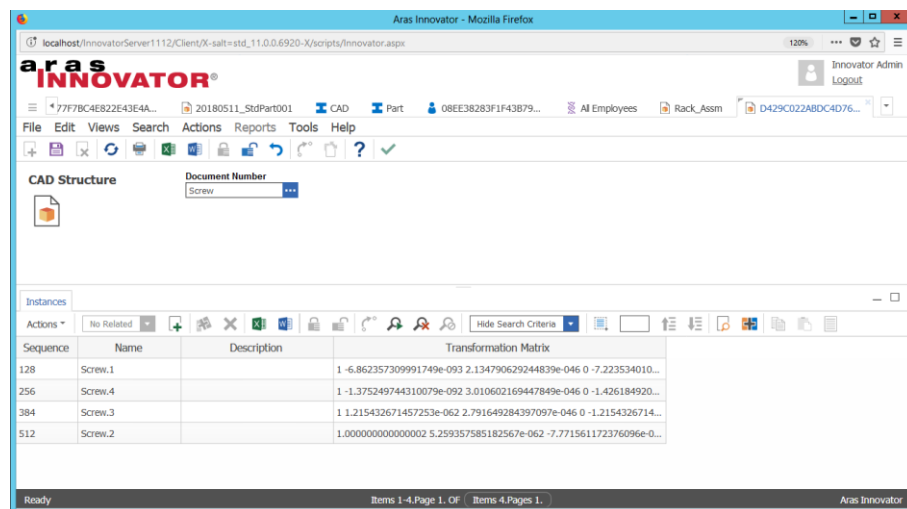

Picture 346: CAD Instance information

“CAD is Master for Instances” Functionality

The PDM Workbench always controls instances by PDM. It reads the instance information from PDM (position, instance name, number of instances). It stores all instance information in PDM, by creating instances.

With this functionality, when a CAD structure is loaded from PDM, the instance information from the CATProduct file is taken, the instance information from PDM is ignored.

At “Update” the instance information in PDM is updated from the current values of the CATProduct, as before. The difference is that the “Load” process is not dependent of the correct, or even existing, instance information in the CAD structure to be loaded.

Check for CAD Document CATIA Release at “Update” Process

This functionality optionally asks before overwriting a file which has been created with a lower release of CATIA V5.

If you are about to overwrite a file which has been created with a lower release of CATIA V5, you are asked whether you want to continue (see *Picture 347: Asking the user whether to continue the “Update” process*).

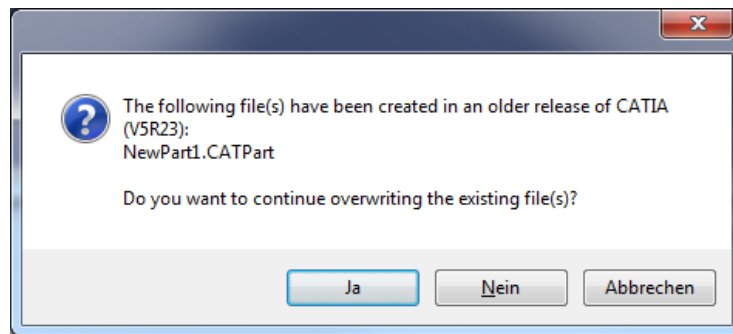

Picture 347: Asking the user whether to continue the “Update” process

Local Workspace Information

It is possible to check the status of the CATIA documents which are downloaded to the local working directory (PWB_XMAP). A list displays the local files and information about their corresponding CAD Documents in PDM if they exist.

When you click on the “Local Workspace” icon (see *Picture 348: “Local Workspace” icon*), a window containing a list of CATIA files appears (see *Picture 349: “Local Workspace” window*).



Picture 348: “Local Workspace” icon



Modified	File Name	Part Number	Major Rev.	Generation	Name	State	Description	Created on	Modified on
No	ConnectionRod.C...	ConnectionRod	A	1	...	Preliminary	...	2018-04-06T11:16:50	2018-04-06T11:17:22
No	ConnectionRodMo...	ConnectionRodMo...	A	1	...	Preliminary	...	2018-04-06T11:16:48	2018-04-06T11:17:22
Yes	CrankPin.CATProd...	CrankPin	A	1	...	Preliminary	...	2018-04-06T11:16:58	2018-04-06T11:17:23
Yes	CrankPinModel.CA...	CrankPinModel	A	1	...	Preliminary	...	2018-04-06T11:16:56	2018-04-06T11:17:23
Yes	Crankshaft_Asm...	Crankshaft_Asm	A	1	...	Preliminary	...	2018-04-06T11:17:04	2018-04-06T11:17:23
Yes	CrankshaftLeft.CA...	CrankshaftLeft	A	1	...	Preliminary	...	2018-04-06T11:17:02	2018-04-06T11:17:23
Yes	CrankshaftLeftMo...	CrankshaftLeftMo...	A	1	...	Preliminary	...	2018-04-06T11:17:00	2018-04-06T11:17:23
Yes	CrankshaftRight.C...	CrankshaftRight	A	1	...	Preliminary	...	2018-04-06T11:16:54	2018-04-06T11:17:23
Yes	CrankshaftRightM...	CrankshaftRightM...	A	1	...	Preliminary	...	2018-04-06T11:16:53	2018-04-06T11:17:24
No	Cylinder_Asm.CA...	Cylinder_Asm	A	1	...	Preliminary	...	2018-04-06T11:16:46	2018-04-06T11:17:24
No	CylinderBlock.CAT...	CylinderBlock	A	1	...	Preliminary	...	2018-04-06T11:16:18	2018-04-06T11:17:24
No	CylinderBlockMod...	CylinderBlockModel	A	1	...	Preliminary	...	2018-04-06T11:16:16	2018-04-06T11:17:24
No	Engine.CATProduct	Engine	A	1	...	Preliminary	...	2018-04-06T11:17:06	2018-04-06T11:17:24
No	FixedParts_Asm.C...	FixedParts_Asm	A	1	...	Preliminary	...	2018-04-06T11:16:30	2018-04-06T11:17:24
-	NewPart10.CATPart	2018-04-09T13:32:55	...
-	NewPart11.CATPart	2018-04-09T13:32:40	...
-	NewPart12.CATPart	2018-04-09T13:32:43	...
-	NewProduct10.CA...	2018-04-09T13:32:37	...
-	NewProduct11.CA...	2018-04-09T13:32:31	...
-	NewProduct12.CA...	2018-04-09T13:32:17	...
No	Piston.CATProduct	Piston	A	1	...	Preliminary	...	2018-04-06T11:16:44	2018-04-06T11:17:25
No	PistonModel.CATP...	PistonModel	A	1	...	Preliminary	...	2018-04-06T11:16:42	2018-04-06T11:17:25
No	PistonPin_Asm.C...	PistonPin_Asm	A	1	...	Preliminary	...	2018-04-06T11:16:40	2018-04-06T11:17:25
No	PistonPincomp.CA...	PistonPincomp	A	1	...	Preliminary	...	2018-04-06T11:16:38	2018-04-06T11:17:25
No	PistonPincompMo...	PistonPincompMo...	A	1	...	Preliminary	...	2018-04-06T11:16:36	2018-04-06T11:17:25

Picture 349: "Local Workspace" window

Configuration of BOM Part Structure

In the BOM Part Structure Data Model it is possible to create product configurations where, depending on the currently set configuration context, only a sub-set of the product structure is expanded and loaded. With this functionality it is possible to create and to work on different configurations of the same product.

This is a small example of the configuration functionality which shows the configuration management with options:

First a category, in this example named "Color", has to be created (see *Picture 350: Creating category "Color"*).

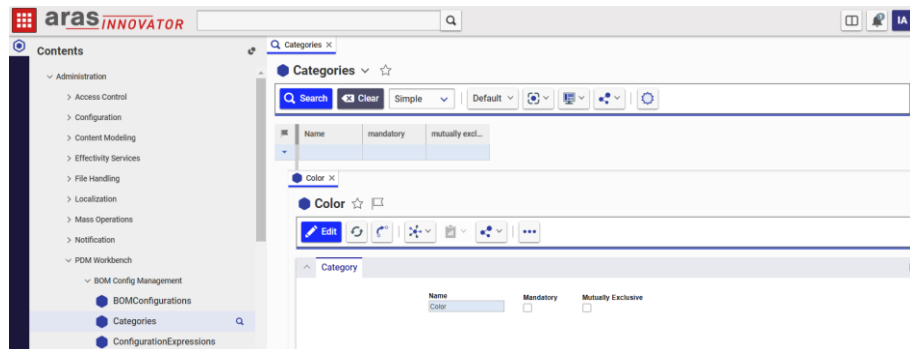

Picture 350: Creating category "Color"

Then option items which refer to the category "Color" are created, in this case named "Blue", "Green", and "Yellow" (see *Picture 351: Creating options "Blue", "Green", and "Yellow"*).

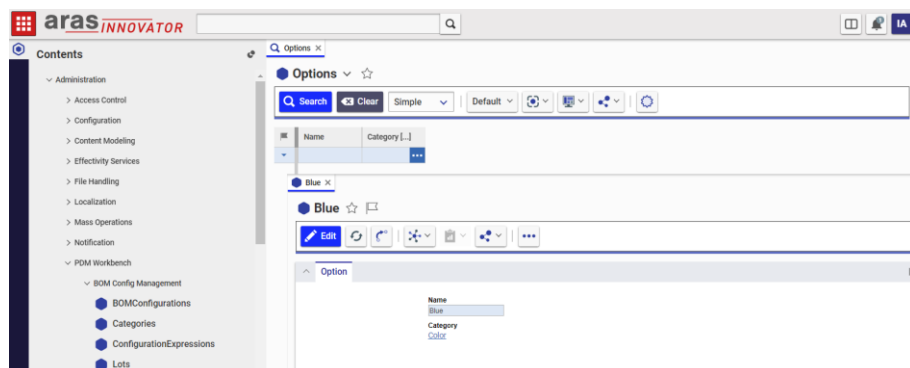

Picture 351: Creating options “Blue”, “Green”, and “Yellow”

Then BOMConfiguration items are created which refer to these color options. The names are “BlueConfig”, “GreenConfig”, and “YellowConfig” (see *Picture 352: Creating BOMConfiguration items*).

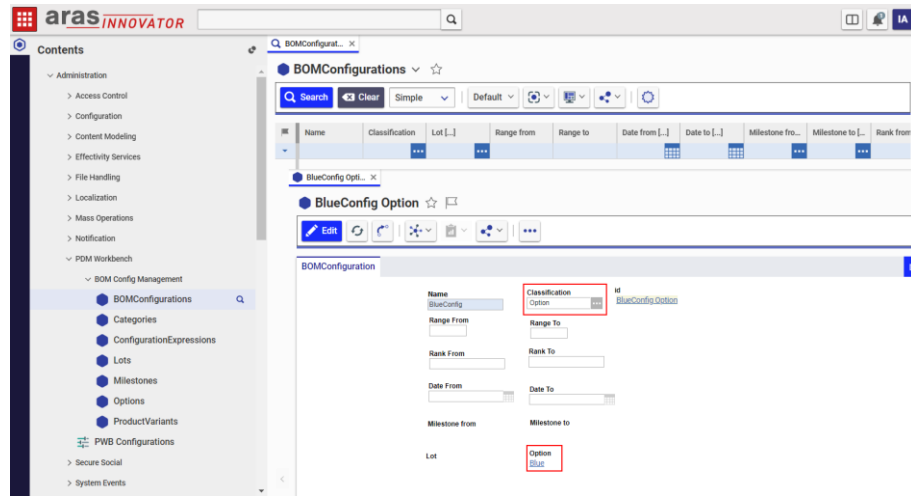

Picture 352: Creating BOMConfiguration items

The next step is to create configuration expressions (“BlueConfigExpr”, “GreenConfigExpr”, “YellowConfigExpr”). Configuration expressions can be combined using the logical operators AND, OR, and NOT (see *Picture 353: Creating Configuration Expression items*).

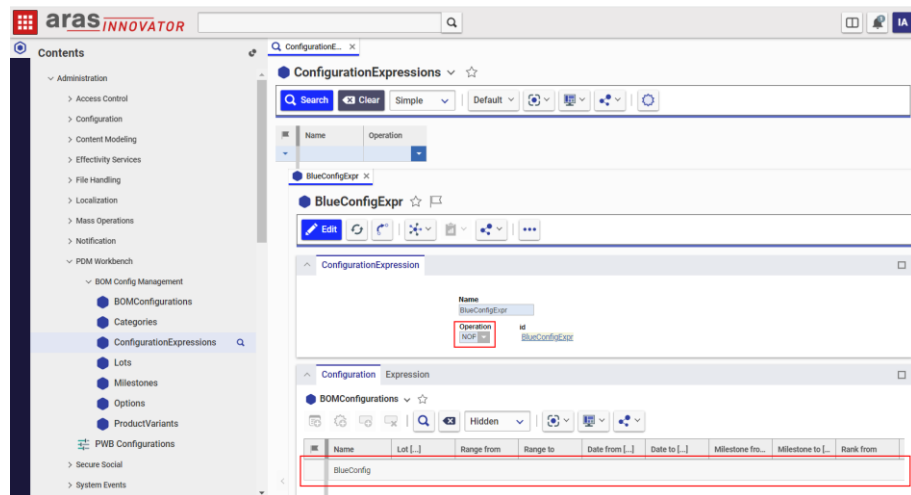

Picture 353: Creating Configuration Expression items

Then a sample CATIA structure is imported, creating a PDM structure in Aras Innovator (see *Picture 354: Sample CATIA structure*).

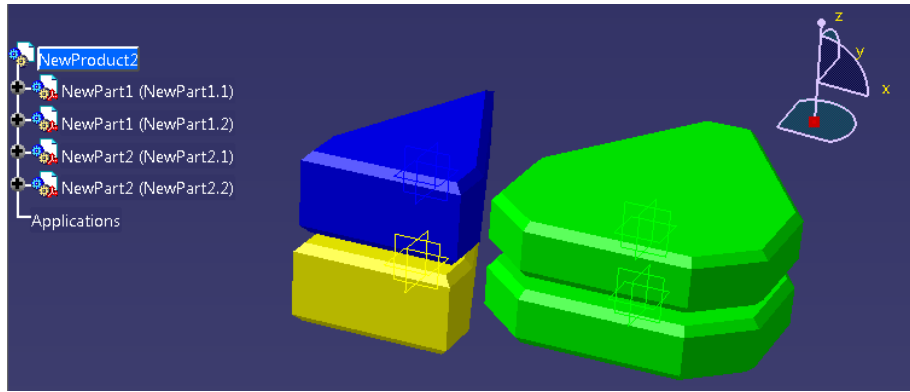

Picture 354: Sample CATIA structure

The previously created ConfigurationExpression items can be related to either “Part BOM” or to “BOM Instance” relation items (see *Picture 355: Relating configuration expressions to PLM relations*).

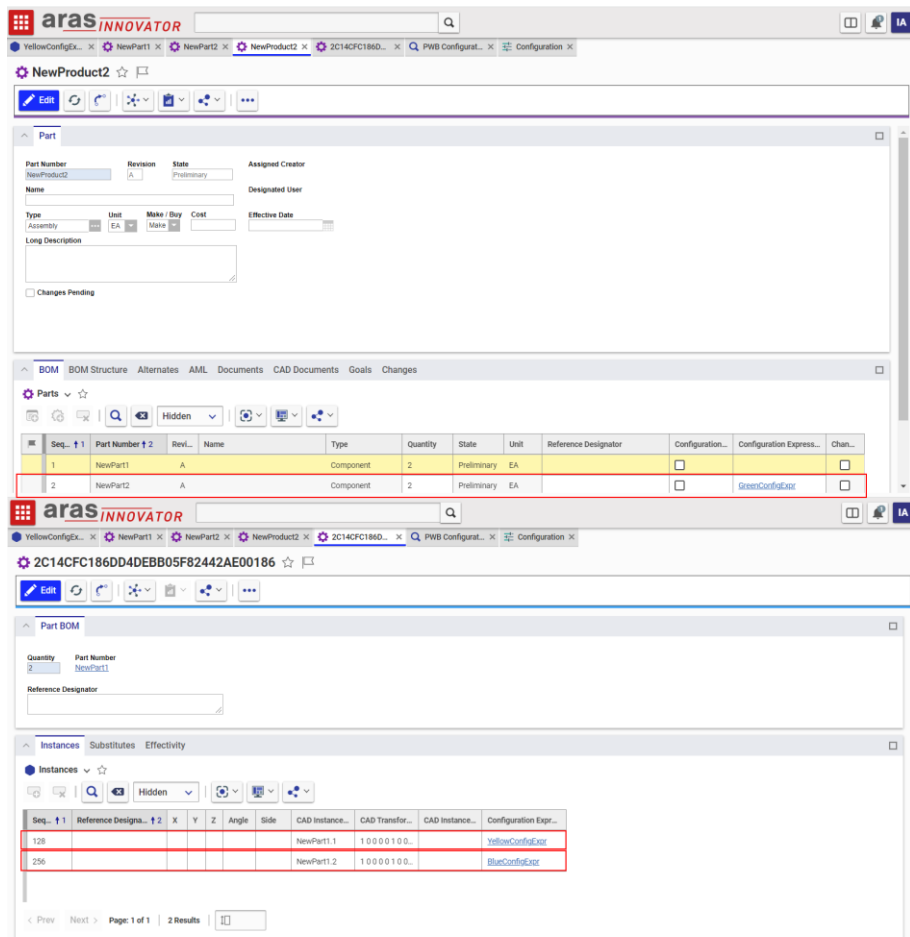

Picture 355: Relating configuration expressions to PLM relations

In order to be able to set the configuration context ProductVariant items have to be created (“BlueVariant”, “GreenVariant”, and “YellowVariant”) (see *Picture 356: Creating Product Variant items*).

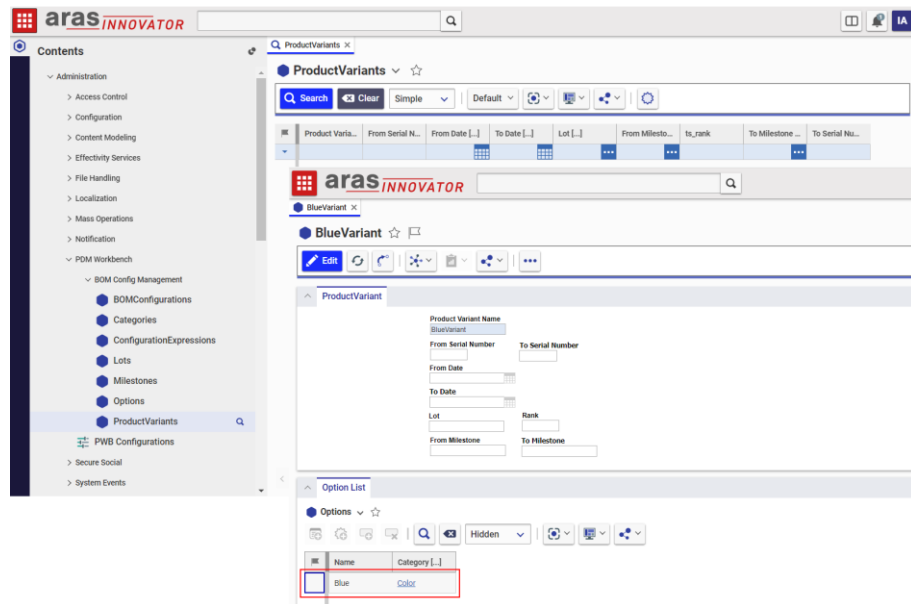

Picture 356: Creating Product Variant items

Now the previously created PDM structure can be expanded and loaded in different configurations (see *Picture 357: Setting a product variant for the BOM part expansion*).



Picture 357: Setting a product variant for the BOM part expansion

First, if no configuration is set, the complete structure is expanded and loaded (see *Picture 358: Expanding and loading the complete structure*).

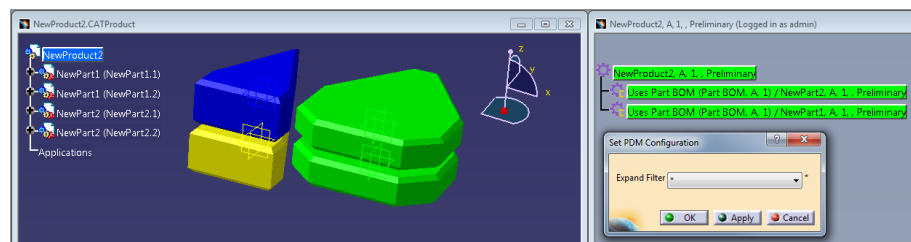

Picture 358: Expanding and loading the complete structure

Then, if a particular product variant is set (see *Picture 359: Setting different product variant expand filters*), expanded, and loaded, then only the configured parts are expanded and loaded (see *Picture 360: Loaded the "Blue" variant (one BOM Instance)*, *Picture 361: Loaded the "Green" variant (one Part BOM with all instances)*, and *Picture 362: Loaded the "Yellow" variant (one BOM Instance)*).

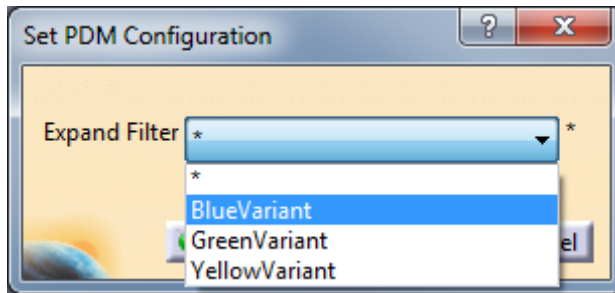

Picture 359: Setting different product variant expand filters

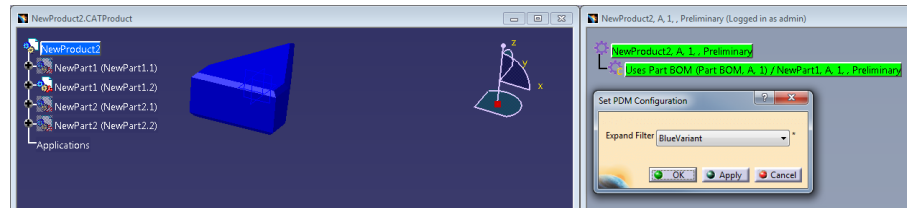

Picture 360: Loaded the “Blue” variant (one BOM Instance)

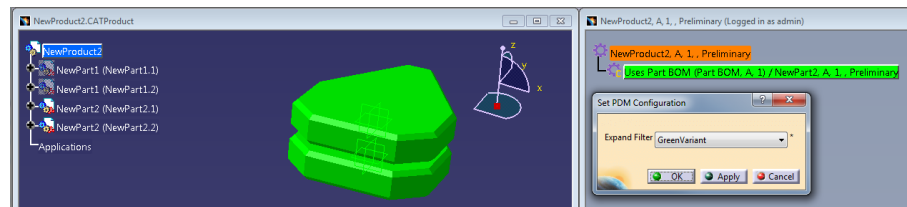

Picture 361: Loaded the “Green” variant (one Part BOM with all instances)

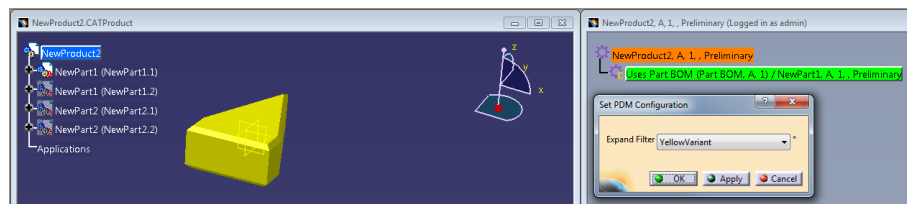

Picture 362: Loaded the “Yellow” variant (one BOM Instance)

CATProduct child instances that are filtered out, that is, not returned by the configuration, are never removed, but they are treated like other parts of a CATProduct structure where parts of the structure have been de-expanded (see *Picture 363: “De-Expand” action*).

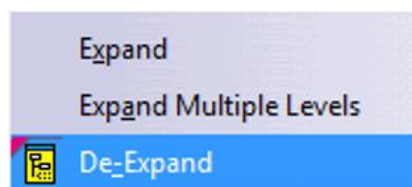

Picture 363: “De-Expand” action

How filtered out or de-expanded CATProduct instances are shown depends on the “Loading PDM structures” setting (see *Picture 364: “Loading PDM Structures” setting*)

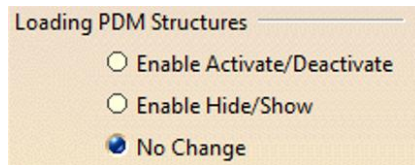

Picture 364: “Loading PDM Structures” setting

and on whether the CATIA file which corresponds to the child instance is present in the local PWB_XMAP directory is present or not.

If the file is present then the child instance is either deactivated (the default setting), or hidden, or not changed.

If the file is not present, then the instance is a broken link. In this case the Activate/Deactivate setting has no effect, for broken links it looks like the “No Change” setting. If “Enable Hide/Show” is set then the broken link will be in hide mode, as shown in the pictures above.

Check CAD Links

When CATIA documents with 3D links need to be imported this functionality helps you to determine which documents have to be imported in which order, and which documents have to be in the CATIA session so the links are created correctly.

When a CATPart or a CATDrawing is the active CATIA document you can click on the “Check CAD Links” icon to get information about which of the linked CATPart documents already exist in PDM, and which still have to be created (see *Picture 365: “Check CAD Links” icon*).

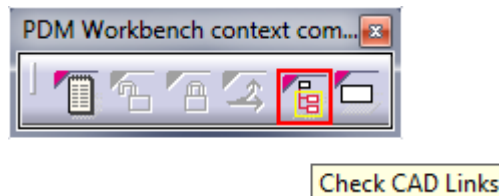

Picture 365: “Check CAD Links” icon

In addition to this the functionality also opens a window containing all the CAD Document items in PDM which should be opened in the CATIA session before the current CATIA document is imported to PDM (see *Picture 366: Result of “Check CAD Links” action*).

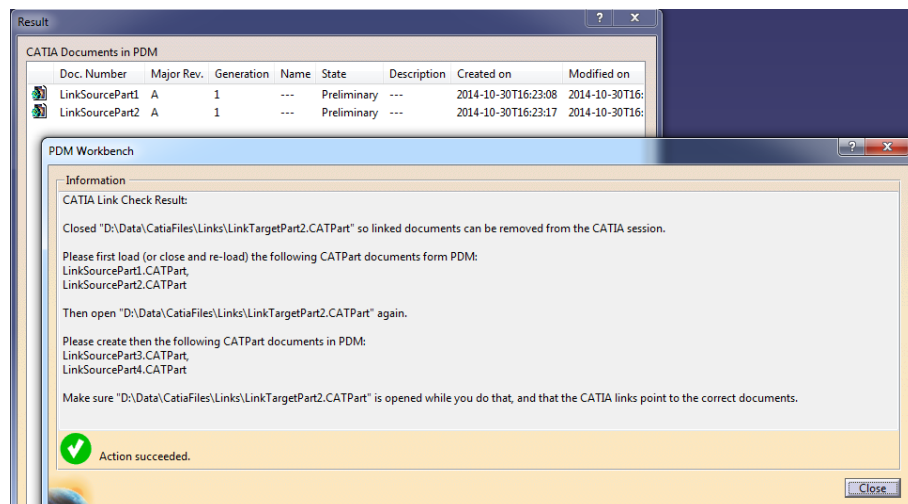

Picture 366: Result of “Check CAD Links” action

Displaying PDM Structure Instances as separate Nodes

The display of the PDM structure in the PDM Structure window can be changed such that every part instance is shown as a separate node.

When this functionality is switched on and a PDM structure containing several instances of the same part is expanded then all the instances are shown as separate nodes (see *Picture 367: PDM structure showing every instance as a separate node*).

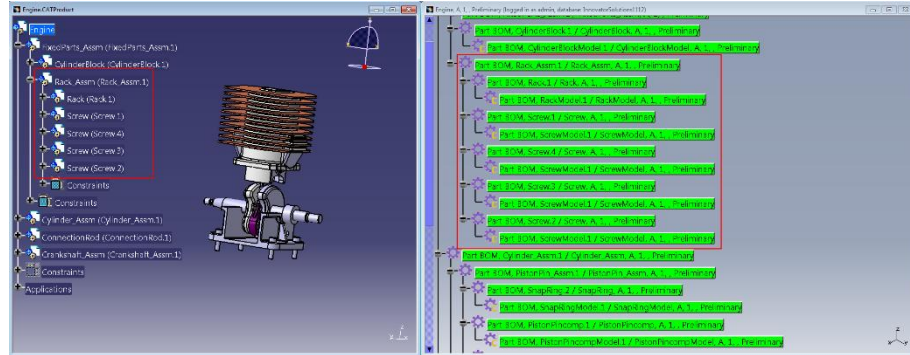

Picture 367: PDM structure showing every instance as a separate node

Saving PDM Session Information

It is possible to save the content of a PDM Structure window in a PWBDoc file, and to reload the content of that window later from that file. The window created by opening the PWBDoc file has the same properties as a PDM Structure window opened by querying and expanding PDM nodes, except that the content may be out of date with the actual server database for a longer time.

The content of any PDM Structure window can be saved to a PWBDoc file (see *Picture 368: Example content of a PDM Structure window*).

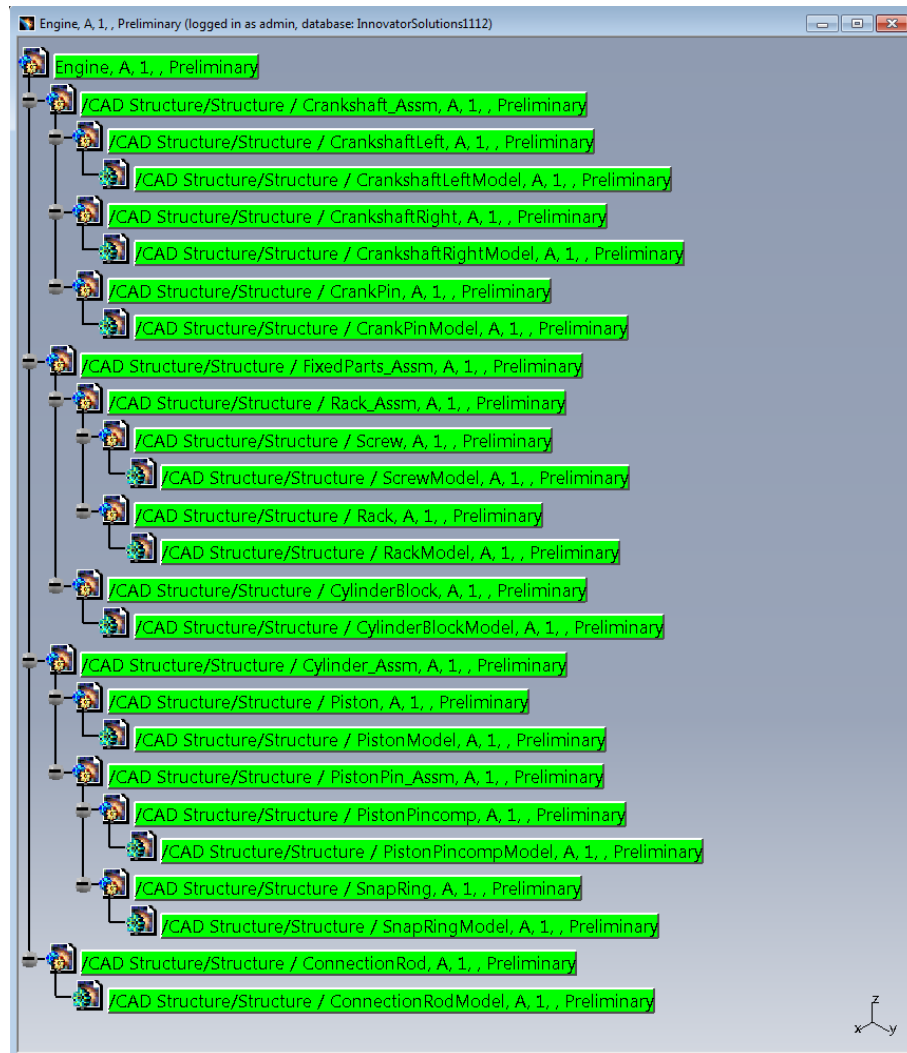

Picture 368: Example content of a PDM Structure window

The content of this window can be saved by selecting “File → Save As” from the menu (see *Picture 369: PWBDoc save dialog* and *Picture 370: Saving the window content under a specific name*).

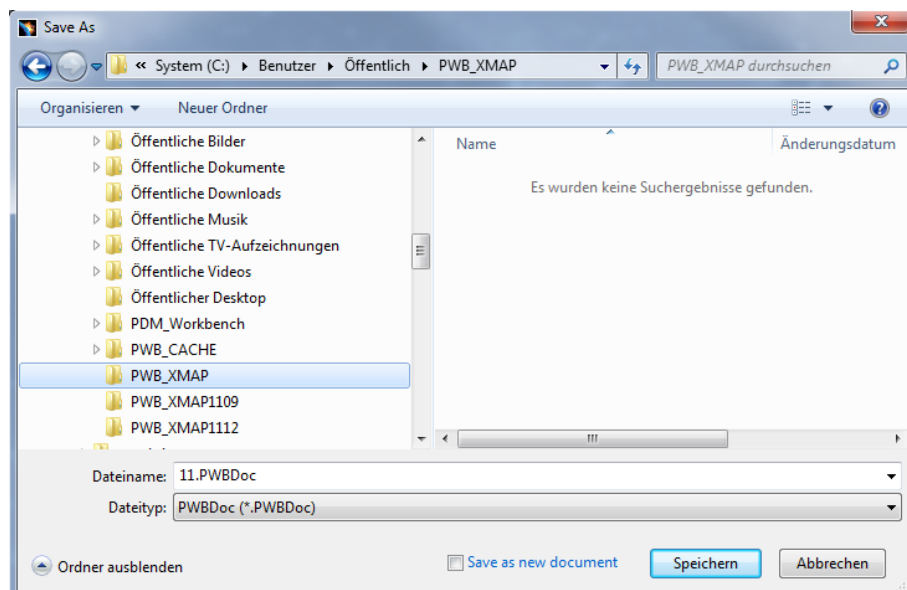

Picture 369: PWBDoc save dialog

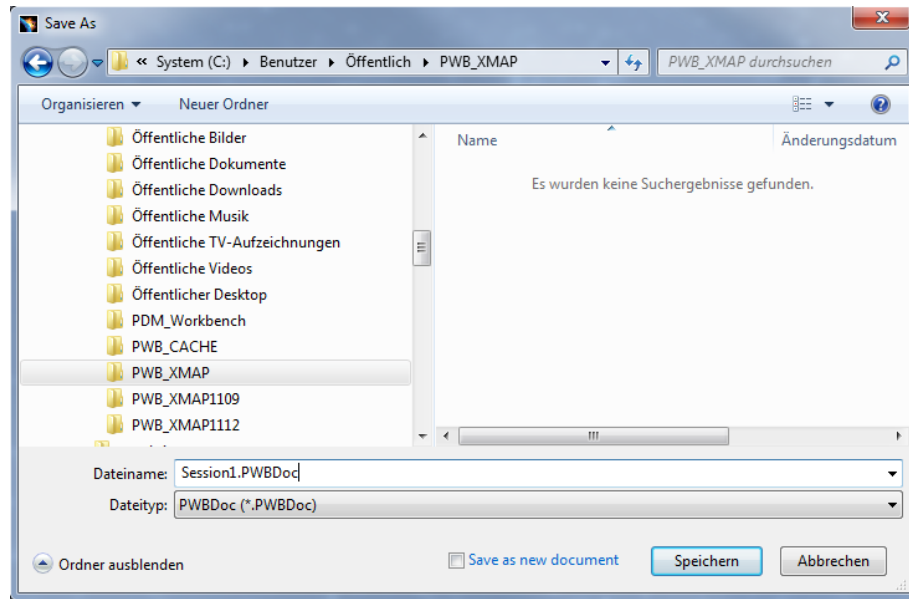

Picture 370: Saving the window content under a specific name

After saving, the new PWBDoc file can be seen in the Windows Explorer (see *Picture 371: Newly created PWBDoc file*).

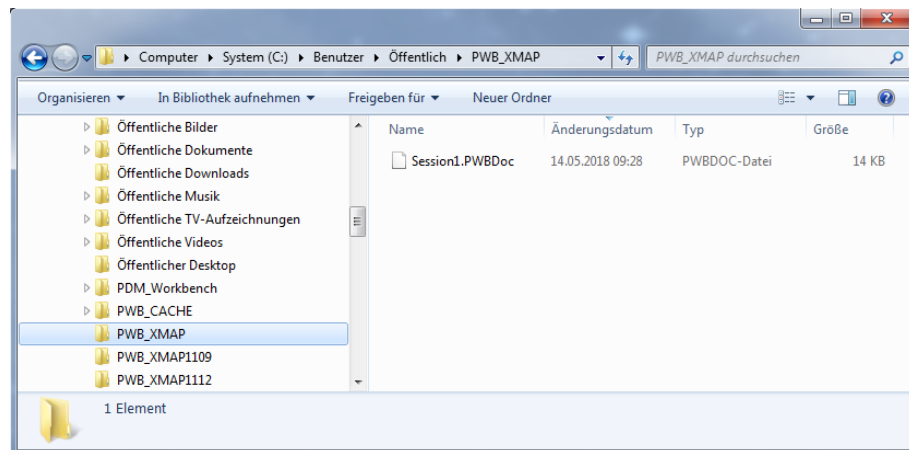

Picture 371: Newly created PWBDoc file

In the same session, or in a later session, this file can be opened again (see *Picture 372: Opening a PWBDoc file (1/2)*, and *Picture 373: Opening a PWBDoc file (2/2)*).

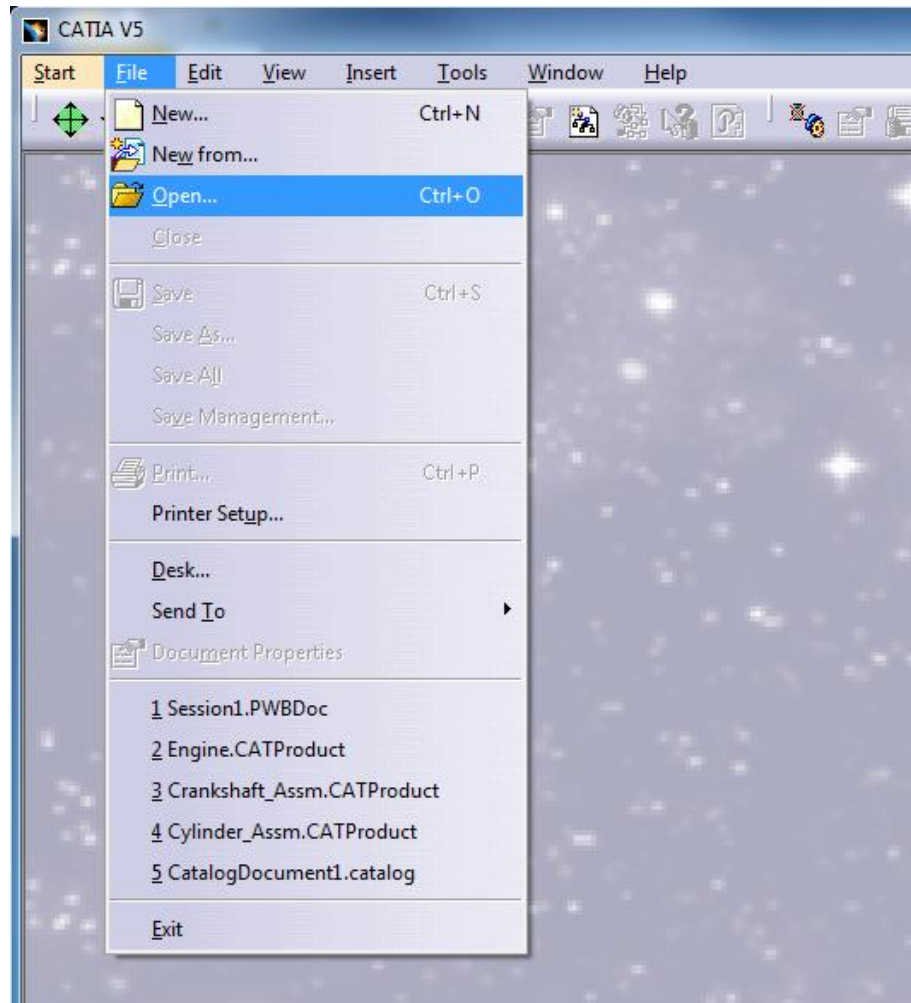

Picture 372: Opening a PWBDoc file (1/2)

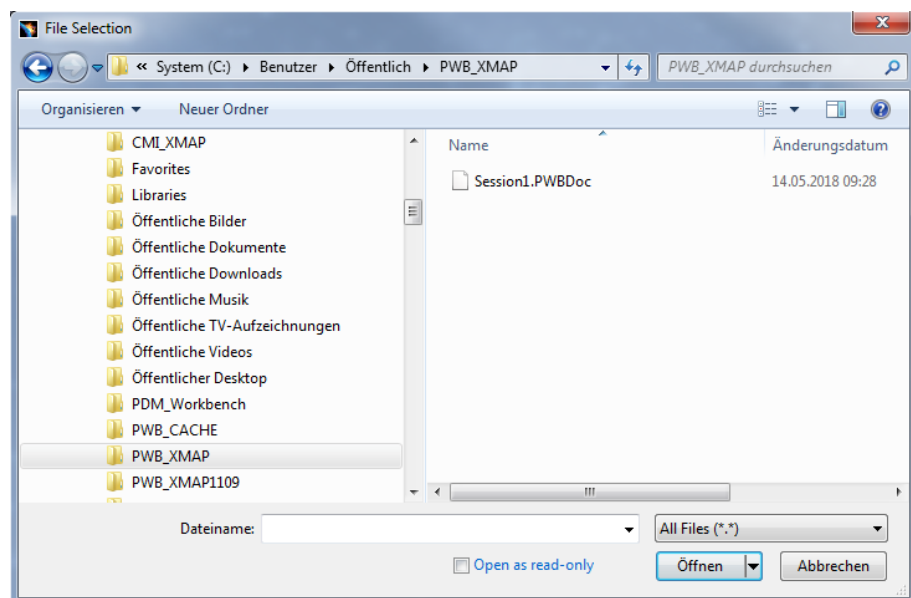

Picture 373: Opening a PWBDoc file (2/2)

The file can also directly be opened from the most recently file list (see *Picture 374: Opening a PWBDoc file from the most recently used file list*).

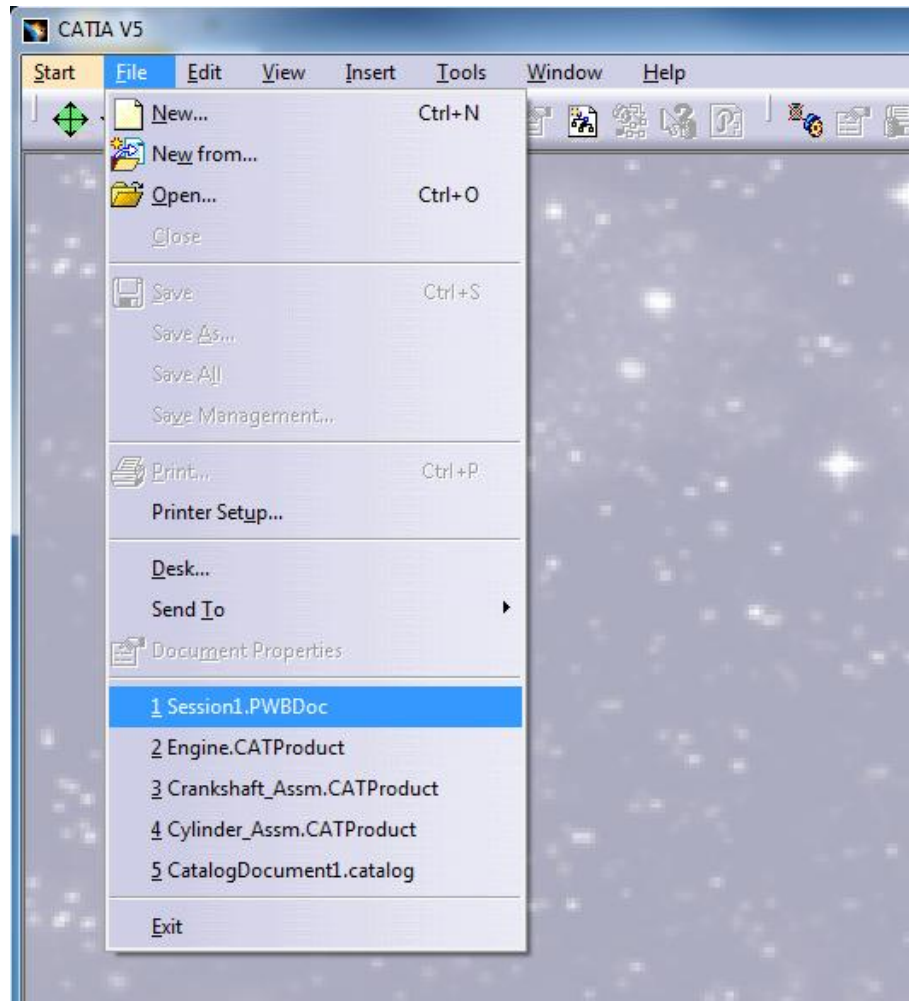

Picture 374: Opening a PWBDoc file from the most recently used file list

You have to be logged on to save or to load a PWBDoc file.

After the file is opened the PDM Structure window can be used like any other opened PDM Structure window (see *Picture 375: PDM Structure window opened from PWBDoc file*).



Picture 375: PDM Structure window opened from PWBDoc file

Allow deactivated CATProduct and CATPart Instances

It is possible to import and update a structure which contains deactivated nodes ("Case.1" in the picture, as opposed to "Screw.1", where only the representation is deactivated) (see *Picture 376: CATProduct structure with a deactivated node*).

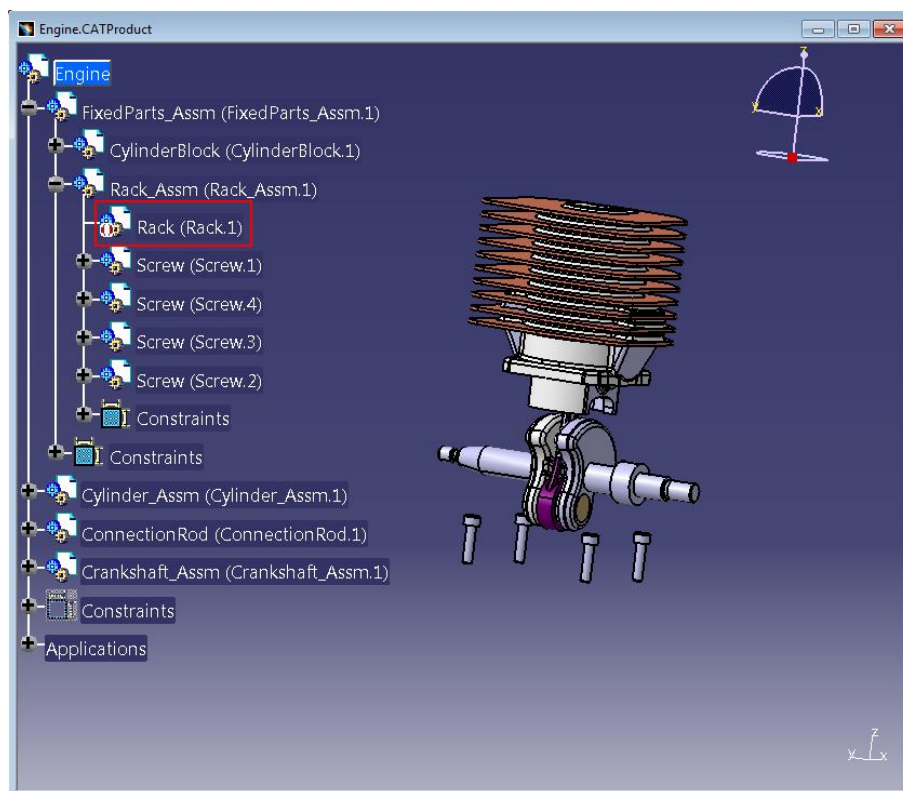

Picture 376: CATProduct structure with a deactivated node

Previously, deactivated nodes were treated as not existing. With this new functionality the nodes can be treated like regular activated nodes.

Also, the activation state of a CATPart or CATProduct instance can be passed to a custom method when the corresponding PDM relation is created, making it possible to different parameter values based on the activation state.

Setting Configuration Information on Structure Relations

It is possible to set configuration information (configuration expression items) to Part BOM and BOM Instance relations in the PDM Structure window.

You can set or remove configuration expression items on the instance (BOM Instance) or reference (Part BOM) relation with the sub-menu actions of the context menu “Update Relation Configuration” (see *Picture 377: Action “Update Relation Configuration” sub-menu*).

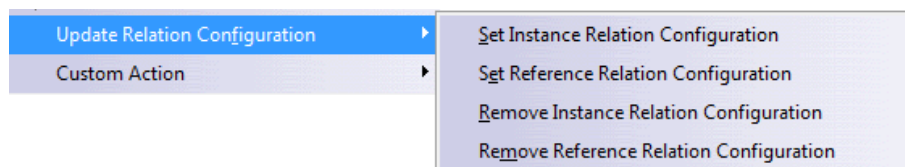

Picture 377: Action “Update Relation Configuration” sub-menu

The relation has to be claimed by you for this.

A configuration expression on a Part BOM relation looks like this ... (see *Picture 378: Configuration expression on Part BOM relation*)

Sequence	Part Number	Revision	Name	Type	Quantity	State	Unit	Reference Designator	Configuration flag	Configuration Expression [...]	Changes
128	NewPart3	A		Component	2	Preliminary			<input type="checkbox"/>		<input type="checkbox"/>
256	NewPart4	A		Component	2	Preliminary			<input type="checkbox"/>	r6-10	<input type="checkbox"/>

Picture 378: Configuration expression on Part BOM relation

... and a configuration expression on a BOM Instance relation looks like this (see *Picture 379: Configuration expression on BOM Instance relation*).

Sequence	Reference Designator	X	Y	Z	Angle	Side	CAD Instance Name	CAD Transformation Matrix	CAD Instance Description	Configuration Expression [...]
128							NewPart3.1	1 0 0 0 1 0 0 0 1 0 32.9...		r1-5
256							NewPart3.2	1 0 0 0 1 0 0 0 1 0 -59.9...		

Picture 379: Configuration expression on BOM Instance relation

Released Cache Mode

The PDM Workbench can efficiently use CGR cache files, which are stored in the Aras Innovator database, for the geometrical visualization of product structures. This is useful when loading large product structures in visualization mode to CATIA.

The PWB cache mode uses CATIA tools to create CGR cache files based on native files like CATIA V5 CATParts or CATIA V4 models, uses Aras Innovator to store and manage these files linked to a CAD Document item in Aras Innovator and uses the CATIA released cache capability to provide the data to you when loading a product structure.

If you use the PWB cache and have loaded a product structure in your current CATIA session in visualization mode, you can switch one or multiple visualized objects to design mode by using the regular CATIA commands or mouse actions (e.g. double-click on a visualized part) for this task.

This works fine even if you have decided to set your “PDM Workbench Options” setting to “Download cache file only”, because the PDM Workbench will download any missing native file whenever CATIA requests it. However, this is not very efficient for switching many objects or larger portions of the product structure to design mode, because the PDM Workbench will then download one requested file after the other.

If the CATProduct contains links that force the load of related CATIA documents, the corresponding native files will be downloaded with each file separately. In such cases it is recommended to use the “PDM Workbench Options” setting “Download native file and cache file” – see next chapter for details.

Set the Cache File Download Mode in User Settings

Each user can define the personal download mode related to cache files in the PDM Workbench settings.

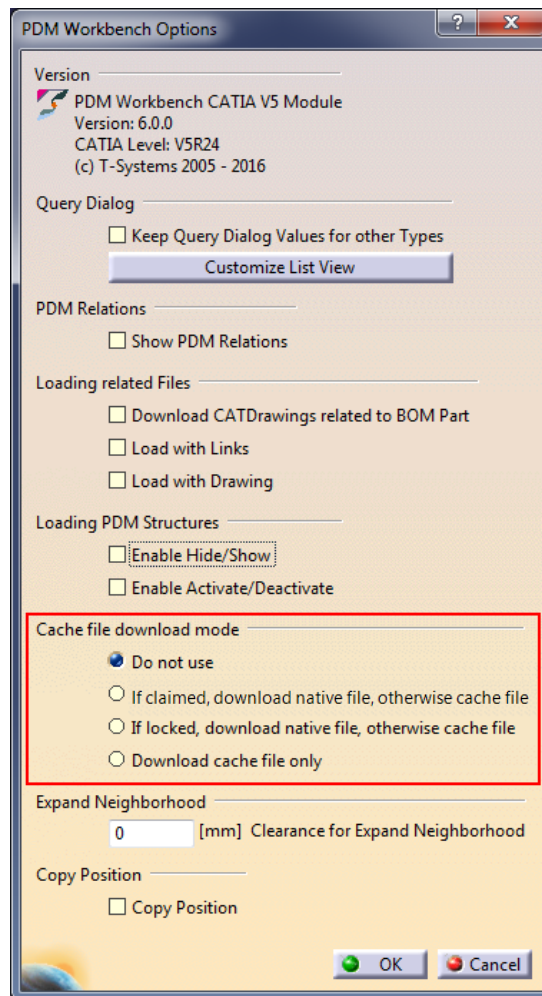

Picture 380: “PDM Workbench Options” dialog - Setting the Released Cache options

You should set it according to your regular or current task. Any change will have immediate effect - from the next download on - for files, which do not exist in the local PDM Workbench exchange directory or are out of date there.

- **Do not use**
 This is the mode of previous PDM Workbench releases. Only native files will be downloaded from the server, even if cache files are provided there.
 This mode can still make sense, if you regularly perform a detailed design based on a small number of loaded files.
- **Download native file and cache file**
 Both files are downloaded for each CAD item, the native file, and the cache file.
 This mode makes sense, if you want a fast initial visualization of your product, but usually switch most or all of it to design mode later.
- **If claimed, download native file, otherwise cache file**
 The download will distinguish between items, which are claimed by the current user, and other files.
 It only makes sense for small product structures and if your work methodology is in a way, that you generally claim all items in PDM that you expect to work on, before you load a product structure to CATIA.

- **Download cache file only**

The native file would not be locally available for immediate access but can be downloaded on demand later.

This mode makes sense for design reviews, where you need the visualization data only, and for loading large product structures, where you might switch only a small portion of it to design mode later.

Command “Get original Geometry”

The command “Get original Geometry” provides an efficient way to collect your requests and download multiple missing files in one shot. Select your CATIA objects like you would do it for the “Switch to design mode” command and call the contextual PDM Workbench command “Get original Geometry”. This would download any missing native file of your selected scope to your PDM Workbench exchange directory (see *Picture 381: Action “Get original Geometry”*).

Your CATIA selection remains active at the end of this command, so it is up to you to immediately switch these objects to design mode after the download or to continue working in visualization mode for some time and to switch to design mode any time later.

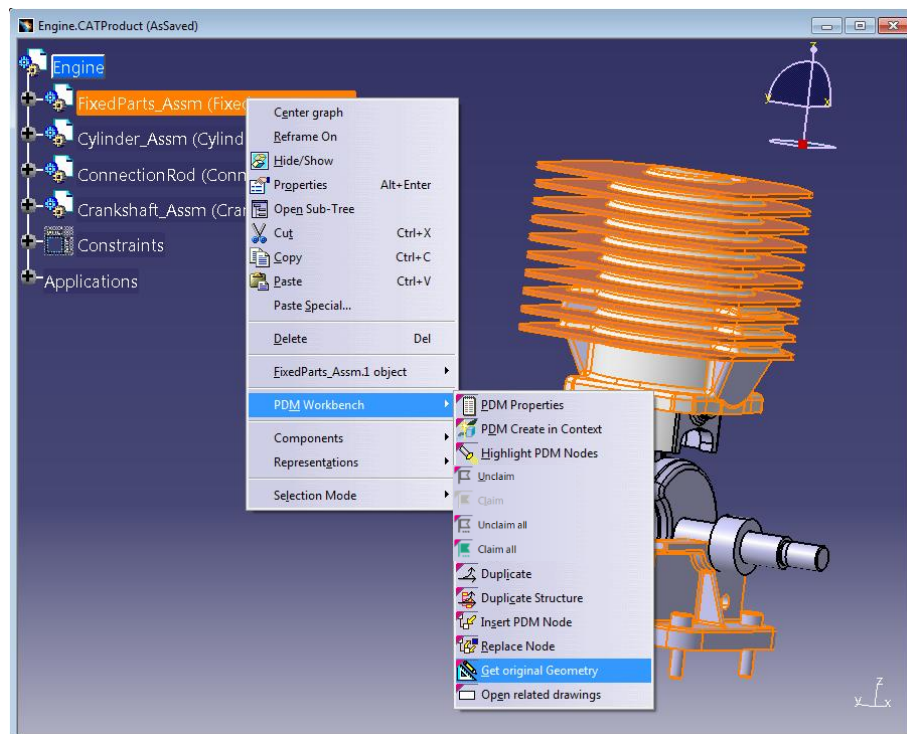

Picture 381: Action “Get original Geometry”

“Open in CATIA” from the Aras Innovator Client

Single CAD or Part items, or structures, can be loaded in CATIA from the Aras Innovator web client.

The precondition for this functionality is that CATIA V5 is started with PDM Workbench, and the user is logged in.

The “Open in CATIA” action in the Aras Innovator web client can be used to load the selected item in CATIA, if it is a component, or to expand the Assembly structure and load it in CATIA.

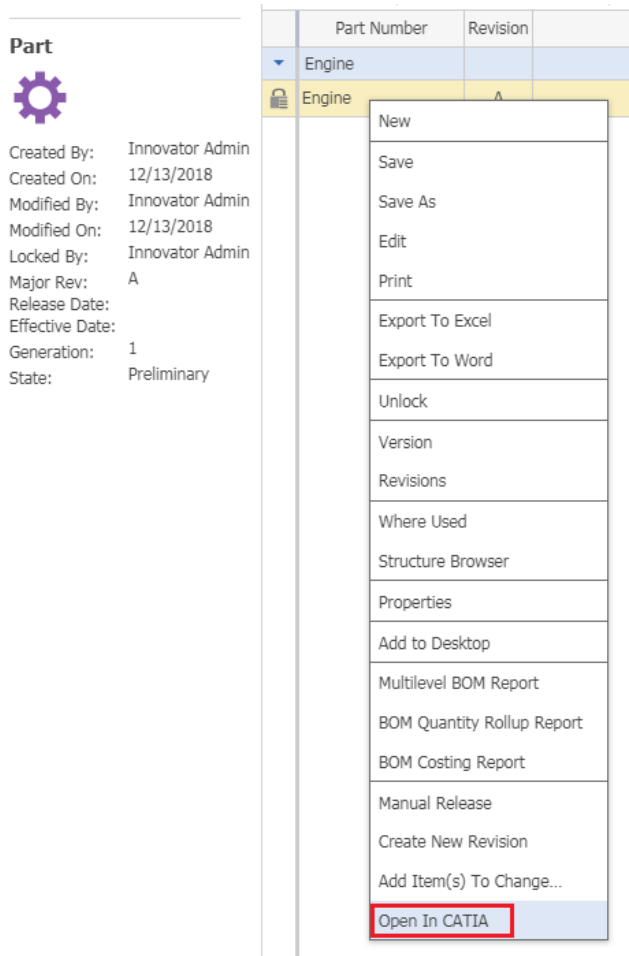

Picture 382: “Open in CATIA” context action

Depending on the selected data model a dialog is opened when the user selected “Open in CATIA” for an item in the Aras Innovator client.

In the CAD Document Structure Data Model are some options

- **Add Temp**
The selected item and its structure is loaded temporarily in CATIA V5.
- **Load with Links**
The selected CAD Document is loaded with the related items.
- **Load with Drawing**
The selected CAD Document is loaded with the related drawings.

and the expand mode available:

- **As Saved**
The structure is expanded “As Saved”.
- **Latest Released**
The structure is expanded “Latest Released”.
- **As Current**
The structure is expanded “As Current”.

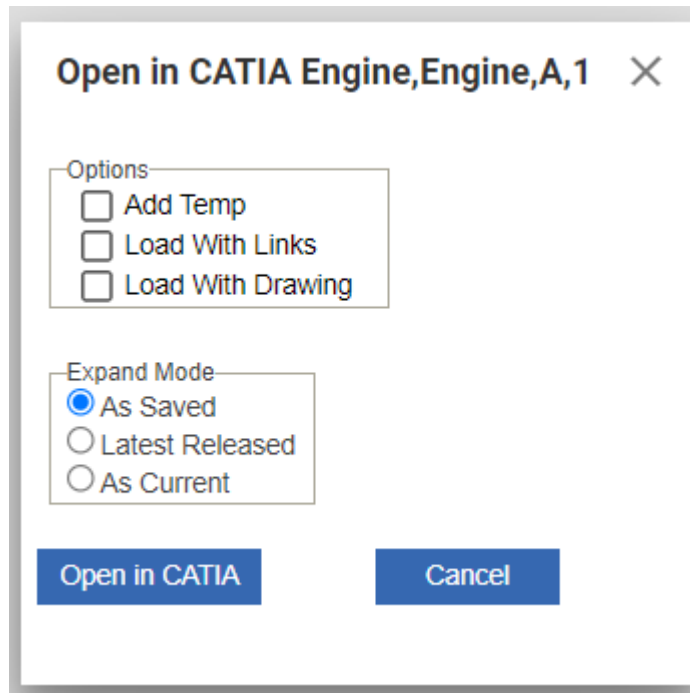

Picture 383: “Open in CATIA” dialog – CAD Document Structure Data Model

In the BOM Part Structure Data Model are some options

- **Add Temp**
The selected item and its structure is loaded temporarily in CATIA V5.
- **Load with Links**
The selected CAD Document is loaded with the related items.
- **Load with Drawing**
The selected CAD Document is loaded with the related drawings.

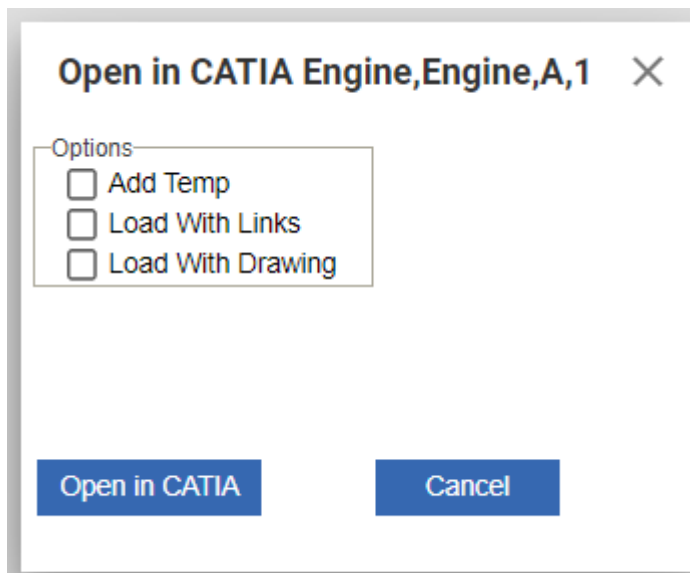

Picture 384: “Open in CATIA” dialog – BOM Part Structure Data Model

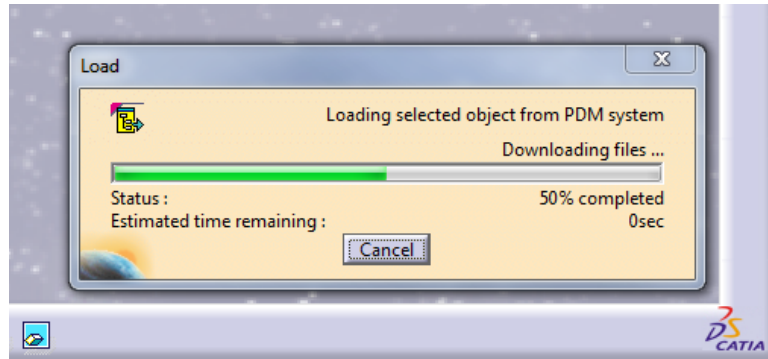

Picture 385: Loading the structure in CATIA

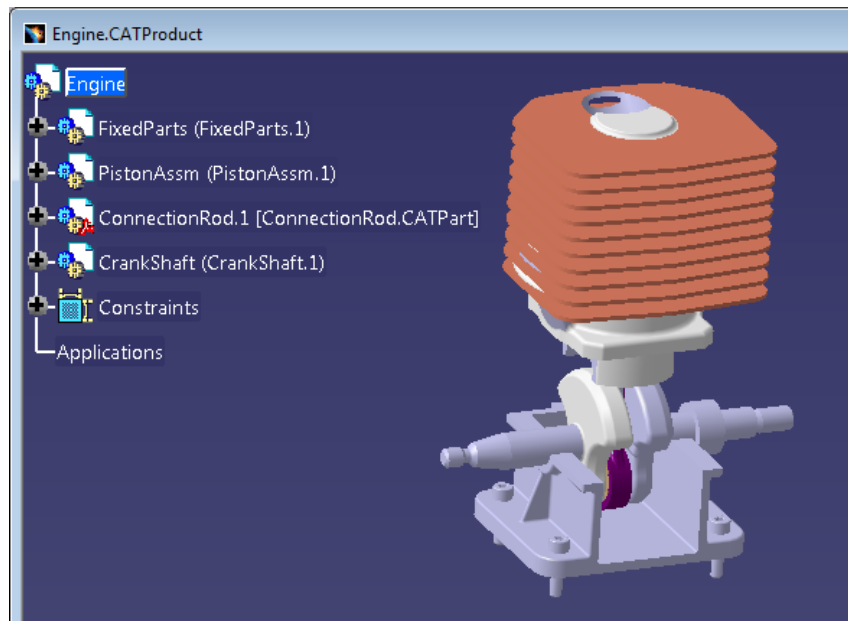

Picture 386: The loaded structure

“Open in CATIA” from the Aras Innovator Client with Construction Space

The Construction Space feature enables the user to set a construction space (assembly/installation space) to filter CAD structures.

The construction space itself represents an axis-aligned bounding-box which is defined by an min point and a max point. This axis-aligned bounding box represents a virtual three-dimensional cuboid, whose sides are the boundaries for the construction space.

Only structures which are located inside the construction space or intersect the construction space are loaded into the CAD application. Because of that the Construction Space feature is integrated into the “Open in CATIA” functionality. The feature is compatible with both CAD and BOM mode for “Open in CATIA”.

Configuration

When installing the “Open in CATIA” data model the Construction Space feature is already included. Configurations might need to be done at the “PwbConstructionSpace” life cycle. *Please be aware that names of the life cycle states should not be modified to ensure the functionality of the Construction Space feature.* The identities to promote life cycle states can be modified to your needs.

Access Rights

In the TOC, the Construction Space can be found at **Administration → PDM Workbench → Construction Space.**

The identity “All Employees” has access to the Construction Space ItemType. Restrictions can be made via the TOC editor.

The usage of the Construction Space ItemType is recommended for the usage of the Construction Space feature.

Construction Space items which are in the “Released” state can be accessed by all users. In the “Draft” state only the creator can use the Construction Space for testing. If only creators should be allowed to access the Construction Space, then it should be left in the “Draft” state.

In the “Obsolete” state the construction space is no longer shown.

All users of the “Aras PLM” identity can promote the life cycle state of the construction space. The identities to promote life cycle states can be modified in the life cycle map.

Usage

In *Picture 387: Create a “Construction Space” item*, the fields marked yellow (Name and Bounding Box) are mandatory. Optionally a description and thumbnails of three different views can be set.

In the Relationship Tab the user can link CAD Documents and Parts to the construction space item. The construction space can then be found when using the “Open In CATIA” functionality with the linked CAD Documents or Parts.

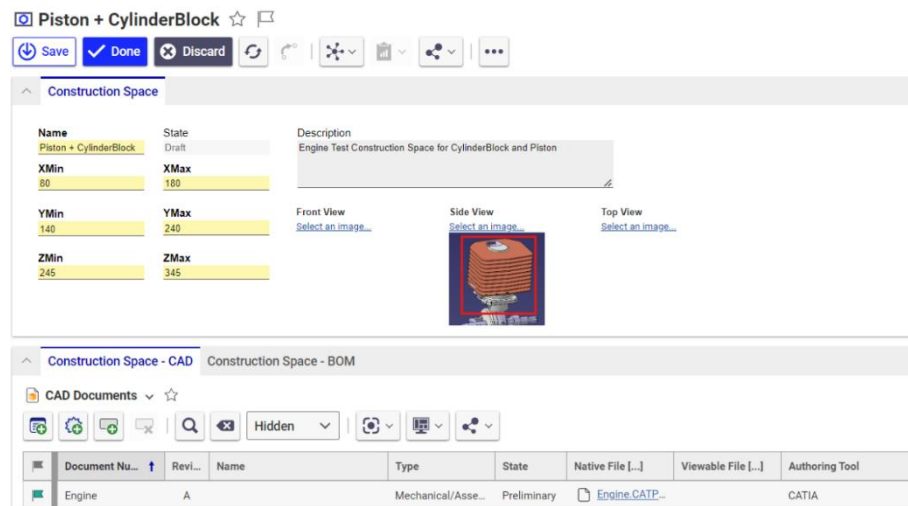

Picture 387: Create a “Construction Space” item

In *Picture 388: “Open In CATIA” option selection* you can see the “Set Construction Space” option. To use the Construction Space feature you have to select “Set Construction Space”.

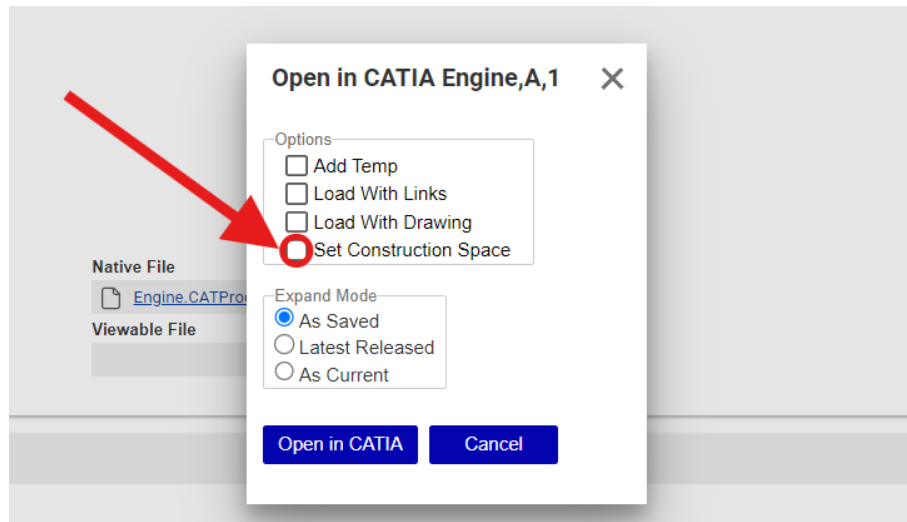

Picture 388: "Open In CATIA" option selection

The previously created construction space linked to the CAD file from which the "Open in CATIA" function was opened is shown when the construction space is selected in the dropdown list. Please be aware that the bounding box values in *Picture 389: "Open in CATIA" with predefined Construction Space* are editable but not saved in the Construction Space item. Permanent changes should be made in the construction space item.

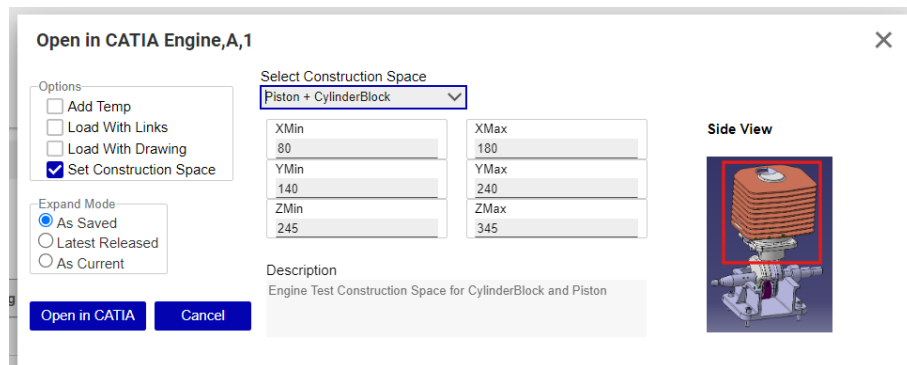

Picture 389: "Open in CATIA" with predefined Construction Space

The message "No related Construction Space items found. Please set own Bounding Box values." appears if there is no Construction Space item linked to the current file. In this case the user can manually set a bounding box by filling the bounding box values into the input mask (see *Picture 390: "Open In CATIA" without predefined Construction Space*).

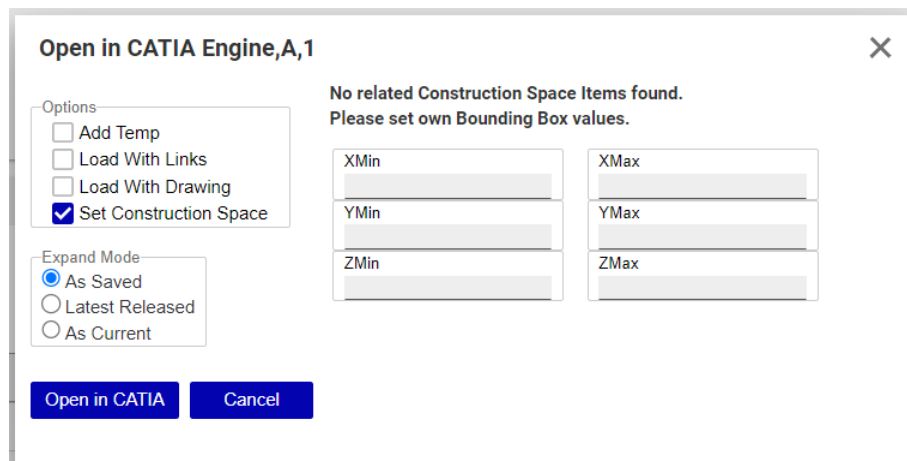

Picture 390: "Open In CATIA" without predefined Construction Space

With a click on “Open in CATIA” the structures within or cutting the construction space are loaded into the CAD application.

“Open in Aras” from CATIA V5 Client

Single CAD or Part items can be loaded in the Aras Innovator web client from CATIA.

The existing Aras Innovator web client session of the default browser will be used to open the object. If there is no session running, the action will open the “Login” dialog first.

The “Open in Aras” action in CATIA V5 can be used to load the selected item in the Aras Innovator web client.

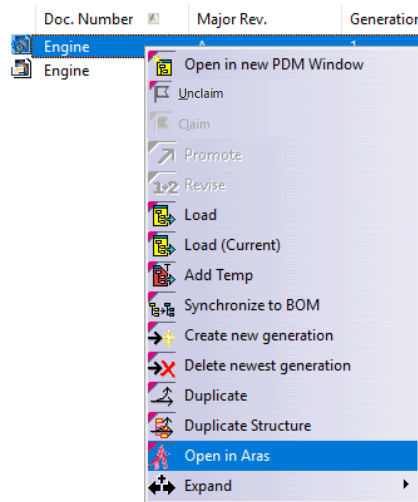

Picture 391: “Open in Aras” context action

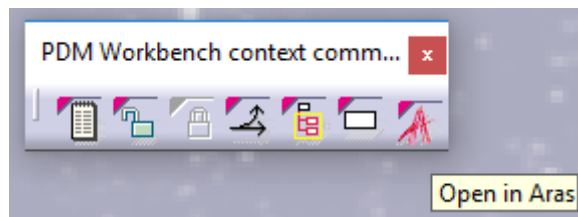

Picture 392: “Open in Aras” toolbar action

Create Drawing CAD Document: Automatically select loaded Part in Session if a single Link exists

If a CATDrawing contains a single link to a 3D CATIA file then that file will be pre-selected in the “PDM Create” dialog for the CATDrawing.

In this example a CATPart has already been created in PDM (BOM Part Structure Data Model) (see *Picture 393: Single drawing link to a CATPart*).

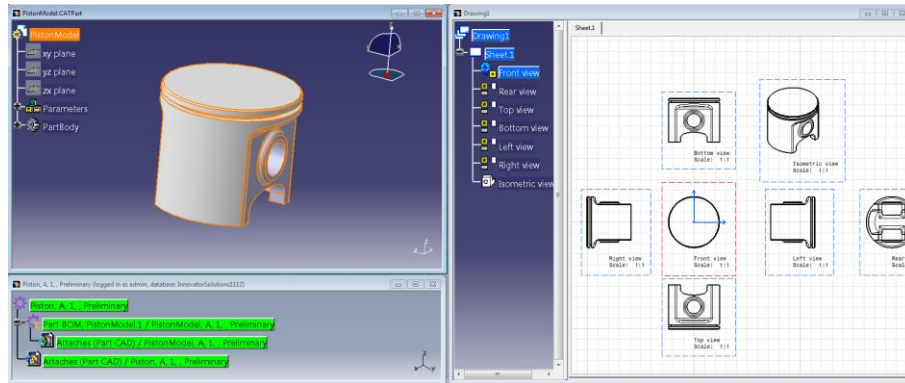

Picture 393: Single drawing link to a CATPart

A CATDrawing with views to the CATPart's geometry is created. The "PDM Create" dialog for the CATDrawing has the CATPart's PDM items already pre-selected (see *Picture 394: CATPart's PDM items pre-selected in "PDM Create" dialog*).

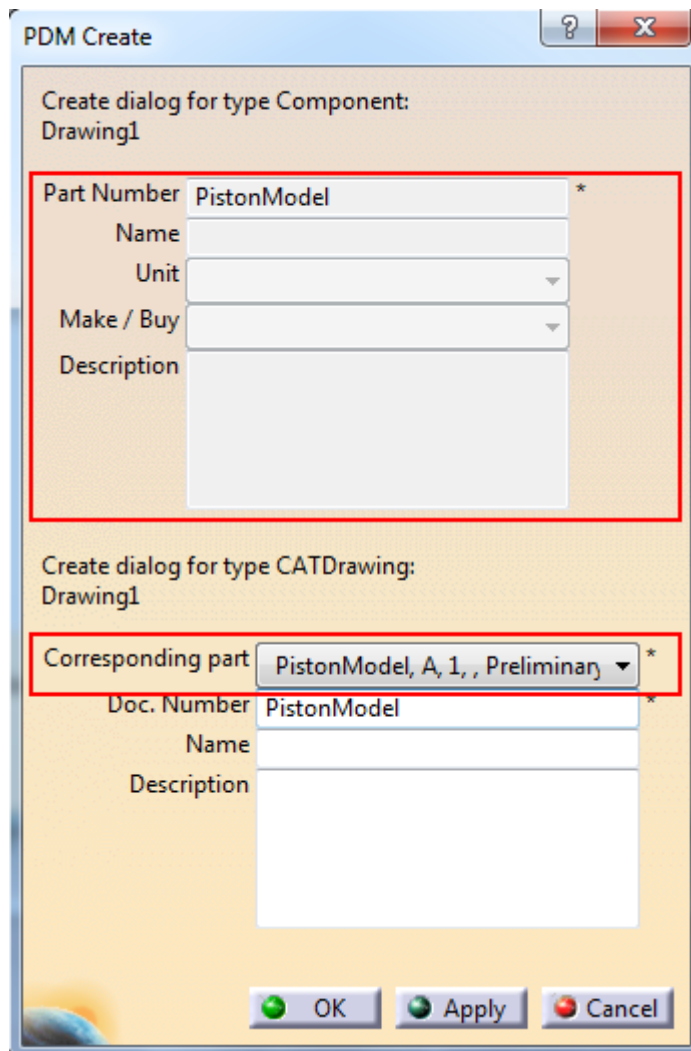

Picture 394: CATPart's PDM items pre-selected in "PDM Create" dialog for CATDrawing

Manage Context Products

A user can only work in one Context Product at one time. This Context Product is used to store newly created files to the correct vault.

If the functionality is enabled, there must be at least one valid Context Product for every user.

The Context Product is set during the “Login” process in CATIA. If there are multiple valid Context Products, the user must select one. If there is no Context Product available for the user, the user cannot login.

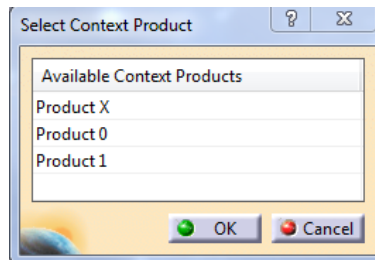

Picture 395: Select Context Product

The currently used Context Product can be seen in the “PDM Workbench Options” dialog.

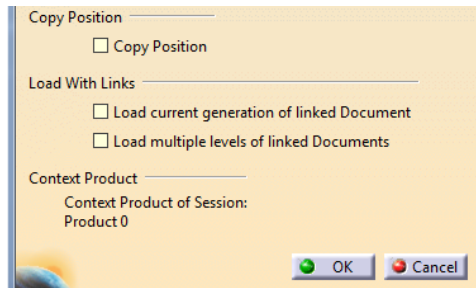

Picture 396: Currently used Context Product

A designer must select a Context Product during selection of the CATIA start script. To avoid a second select it is possible to use an environment variable to set the Context Product.

Options

Once you are logged in into the PDM Workbench you can set some options for the PDM Workbench.

You open the “Options” dialog with *Tools*→*Options* in CATIA V5. In the slider “PDM Workbench” you can set the options for the PDM Workbench (see *Picture 397: PDM Workbench options*).

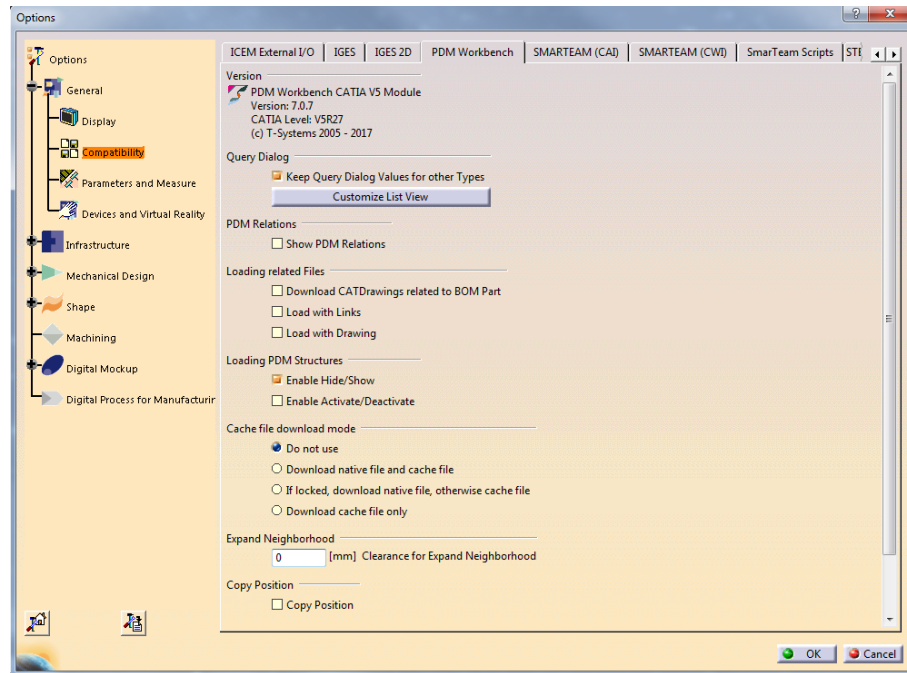

Picture 397: PDM Workbench options

Query Dialog

When you set “List View” for the Query Mode the query result will be opened in a list view window.

You can customize the columns to be used in the list view window.

Please click "Customize List View" to open the "Customize List View" dialog (see *Picture 398: "Customize List View" dialog*).

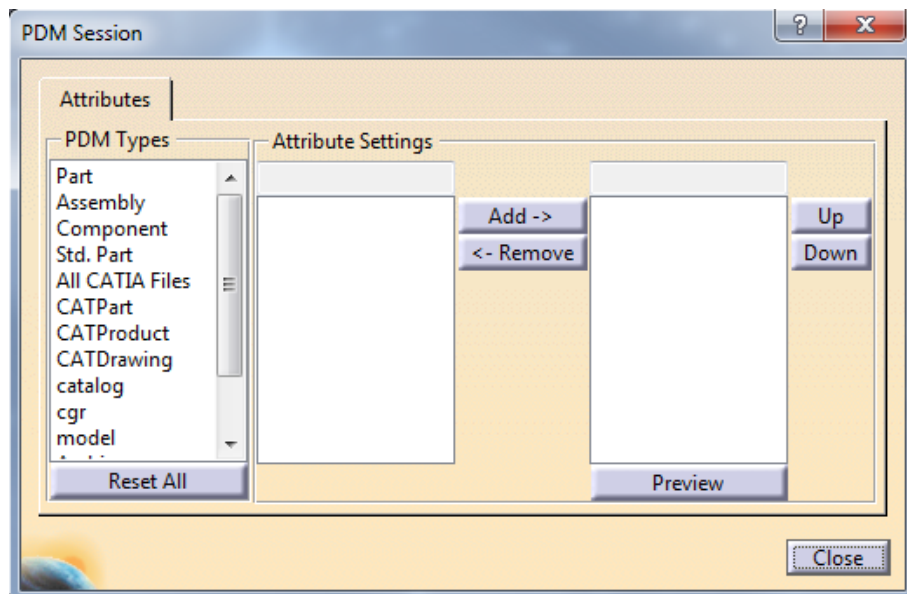

Picture 398: "Customize List View" dialog

When you are using a new PDM Workbench configuration file then you have to reset the column settings by clicking on "Reset All".

In order to customize the columns for an object type you have to select the object type. In the example in *Picture 399: "Customize List View" dialog for "Assembly"* the object type "Assembly" has been selected. In the right part of the dialog the attributes to be shown as columns are displayed. In the middle part of the dialog the attributes not to be shown as columns are displayed. In this case no attribute is hidden.

You can select an attribute on the right and remove it by clicking on the "Remove" button. Or you can select an attribute in the middle and by clicking on the "Add" button you can add it to the columns to be shown.

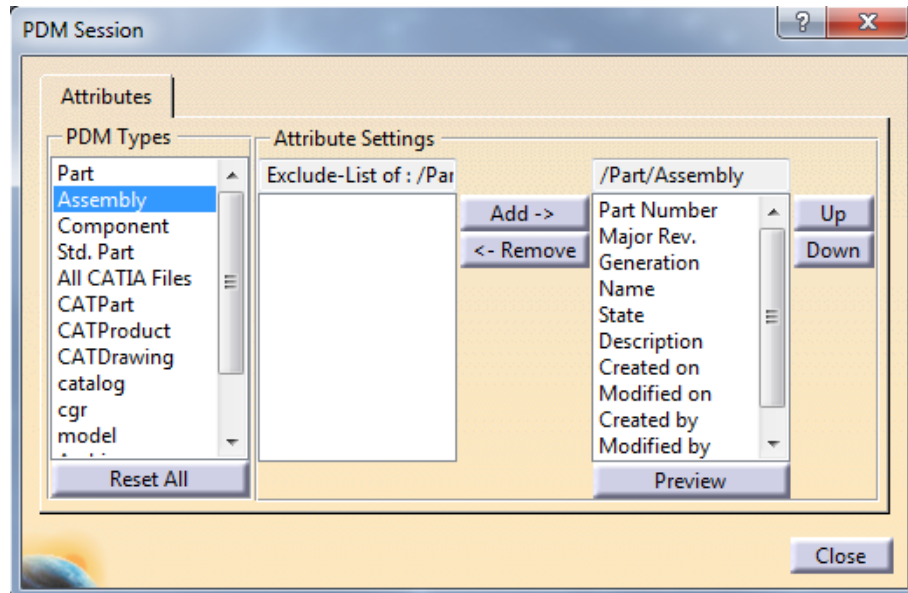

Picture 399: "Customize List View" dialog for "Assembly"

By clicking on the "Preview" button you can see a preview of the list view (see *Picture 400: Preview of the "List View" dialog*).

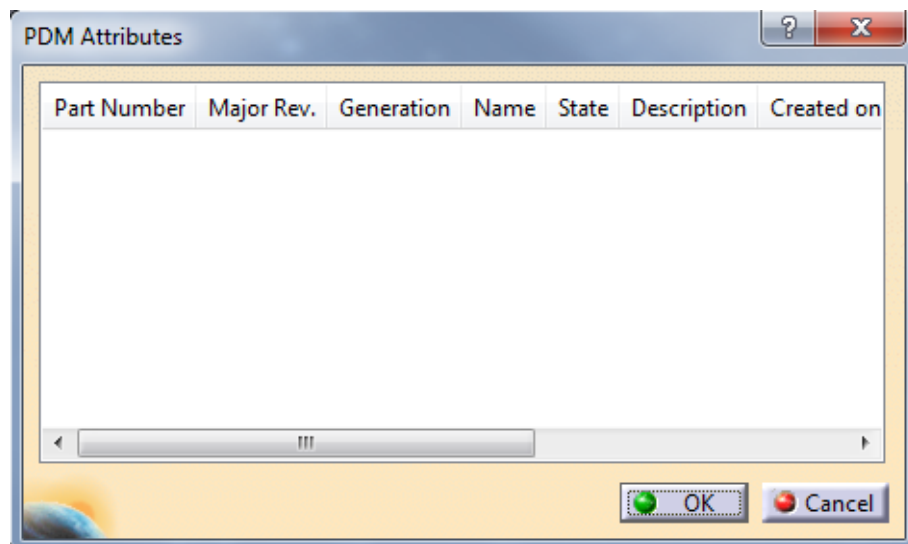

Picture 400: Preview of the "List View" dialog

PDM Relations

You have the possibility to hide or to show the PDM relations in the PDM structure.

CATDrawings

CATDrawing files that are related to the root part of a PDM structure can be automatically downloaded when the PDM structure is loaded to CATIA.

Loading related Files

Defines whether only the selected structure, or also files which are related by drawing or reference links should be downloaded.

Loading PDM Structures

When a PDM structure is loaded to CATIA substructures in the CATProduct tree can be hidden or deactivated if their corresponding PDM structures are not expanded.

Cache File Download Mode

Defines the options of the “Released Cache” functionality. Please refer to the “Released Cache Mode” chapter for more information.

Expand Neighborhood

Defines the clearance in millimeters for the “Expand Neighborhood” functionality.

Copy Position

Defines whether the position information of copied relations should also be copied to the new relations.

PDM Session Configuration

No configuration has to be set currently from CATIA for the Aras Innovator integration.

The configuration has to be made directly in the Aras Innovator application. For details please refer to the *PDM Workbench Installation & Administration Manual*.

Logout

Once you finished your work in PDM Workbench you do a Logout from the PDM system.

You select the “Logout” icon  within the PDM Workbench toolbar (see *Picture 401: PDM Workbench toolbar after login*) in CATIA V5 ...



Picture 401: PDM Workbench toolbar after login

... and the session in the PDM system will be closed.

All PDM Workbench windows get closed. Please consider that CATIA native windows resulting from a “Load” or “Open File” PDM Workbench context action remain opened but that they are now out of synchronization with the PDM system. So, we recommend you to close them, too.

CHAPTER 4

Additional optional functionality

This chapter describes optional functionalities of the PDM Workbench which are able to be added in the CATIA V5 workshop.

Copy Element Attributes

It is possible to copy the attributes from a PDM object in order to use them in a “PDM Create” dialog.

You can select a PDM object in the PDM window and click on the right mouse button. Then you select the action “Copy element attributes” (see *Picture 402: Action “Copy element attributes”*).

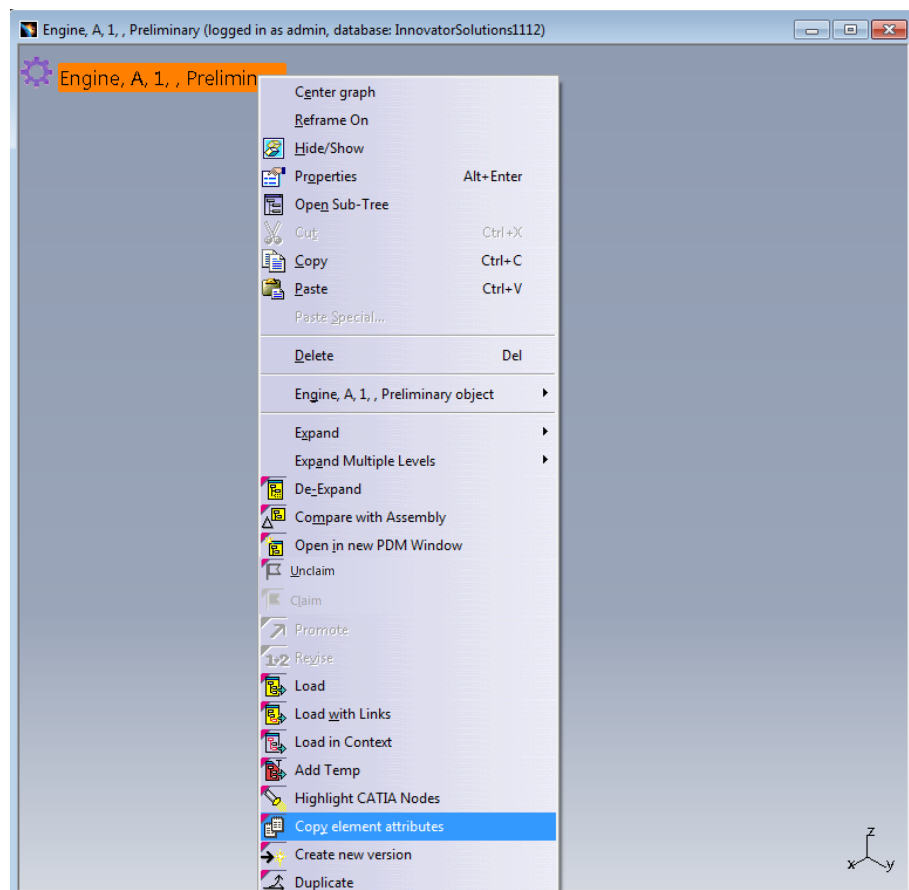

Picture 402: Action “Copy element attributes”

The attributes will be copied to the clipboard.

In the next step you select the action "Create" from the toolbar and select the corresponding class for the object to be created, in this case "Assembly" for the copied attributes of the "Engine". The "PDM Create" dialog will be opened. It has the "Insert attribute values" button (see *Picture 403: "PDM Create" dialog for Assembly*).

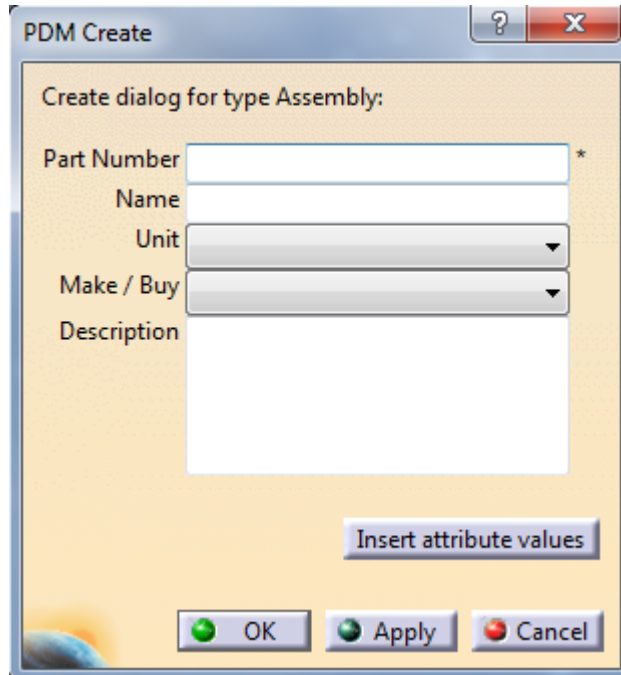

Picture 403: "PDM Create" dialog for Assembly

When you click on the "Insert attribute values" button the attributes of the dialog will be filled (see *Picture 404: "PDM Create" dialog for Assembly – Inserted attribute values*).

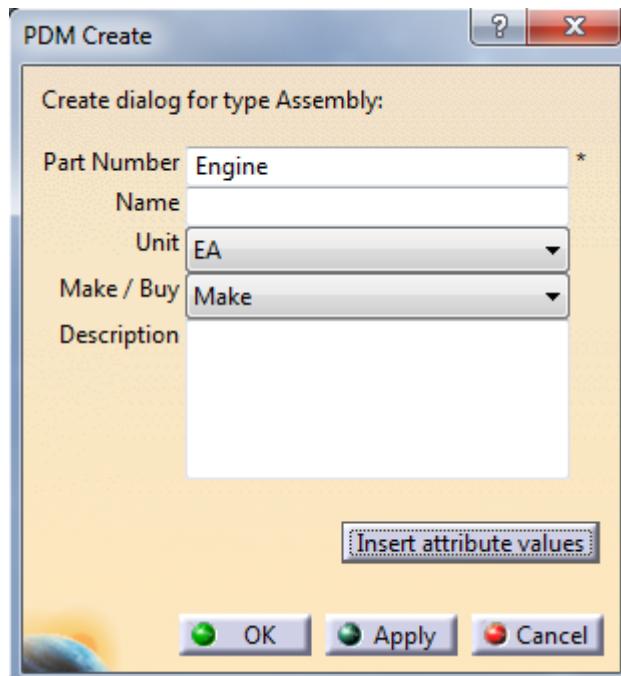

Picture 404: "PDM Create" dialog for Assembly – Inserted attribute values

You can change the attribute values and start the "Create" process by clicking on the "OK" button.

Autaname Support using Aras Innovator Sequence Items

It is possible to optionally use Aras Innovator sequence items to rename CATIA structures or single CATIA documents when they are created (see *Picture 405: CATIA structure before and after import to PDM*).

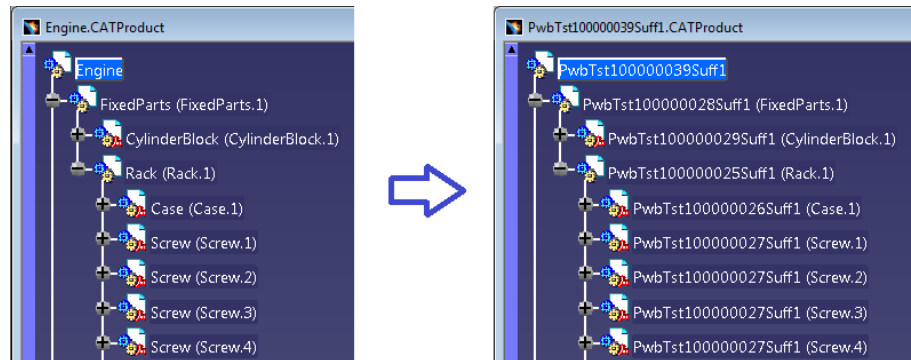

Picture 405: CATIA structure before and after import to PDM

In the “Login” dialog you can select one of the autaname rule (Aras Innovator sequence item) names (see *Picture 406: “Login” dialog with autaname rule*).

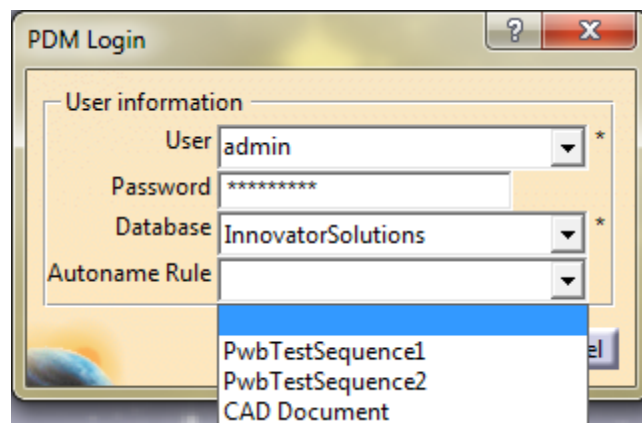

Picture 406: “Login” dialog with autaname rule

If none of the names are selected then the “Autaname” functionality is not used.

Later in the session you can change the selected autaname rule by clicking on the “PDM Session Configuration” icon in the PDM Workbench toolbar and selecting one of the sequence item names. This dialog can also be used to switch off the “Autaname” functionality by selecting the entry containing the empty string (see *Picture 407: “Set PDM Configuration” dialog* and *Picture 408: Autaname rule combo box in “Set PDM Configuration” dialog*).

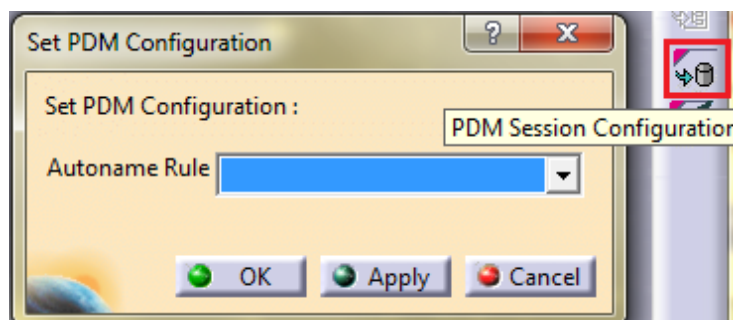

Picture 407: “Set PDM Configuration” dialog

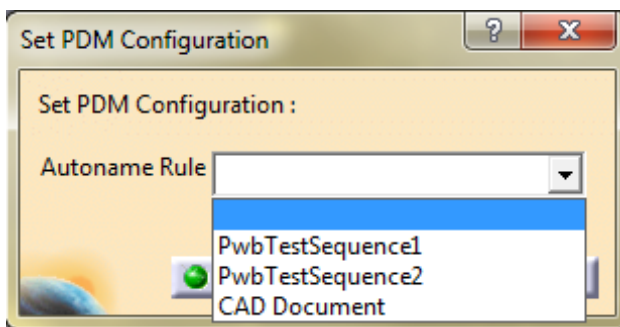

Picture 408: Autaname rule combo box in “Set PDM Configuration” dialog

If an autaname rule is selected the “Update to PDM” dialog will contain the information which autaname rule is selected (see *Picture 409: Selected autaname rule displayed in “Update to PDM” dialog*).

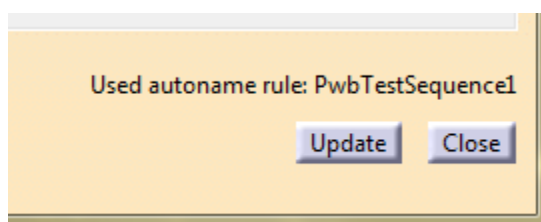

Picture 409: Selected autaname rule displayed in “Update to PDM” dialog

After creating new PDM items which correspond to the new CATIA documents the CATIA files will be renamed. The CATIA instance names will not change.

The corresponding PDM items will also have the names created by the selected sequence item (see *Picture 410: PDM structure named by sequence item*).

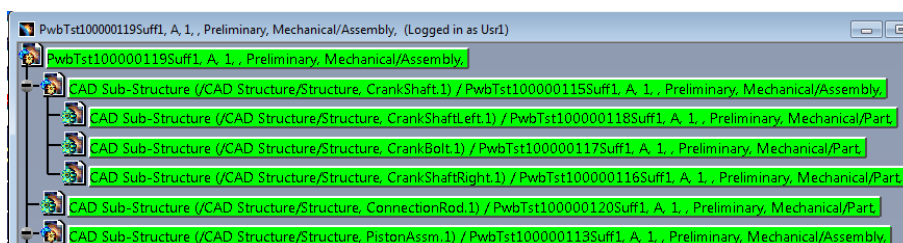

Picture 410: PDM structure named by sequence item

Further updates will not affect the names of the CAD Documents and PDM items.

Possibility to call a Server Method for a PDM Item

It is possible to call custom server methods with a PDM item and optionally with a dialog as input.

You can right-click on a PDM item and select one of the custom server methods.

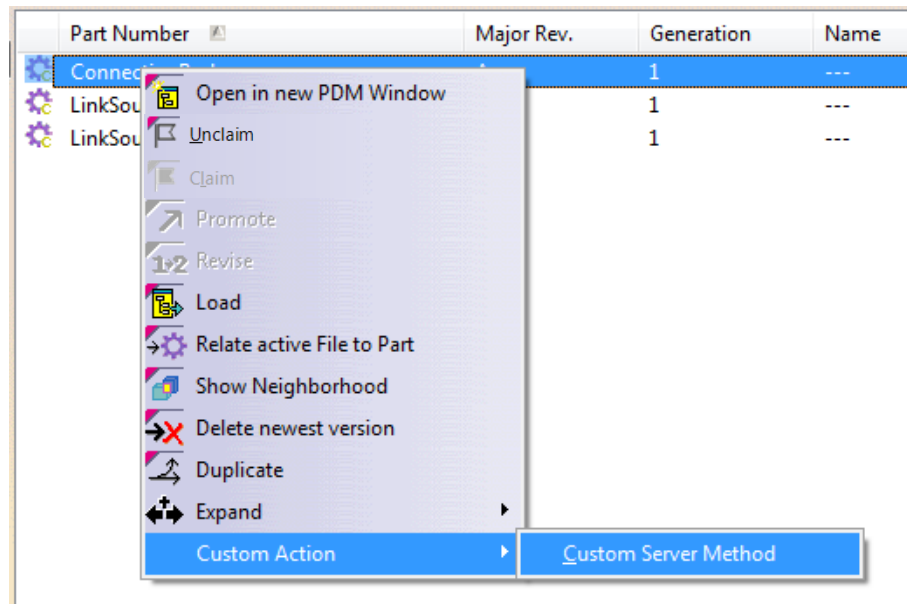

Picture 411: Selecting a custom method on a Part item

If a dialog is configured it appears pre-filled with the attributes of the item:

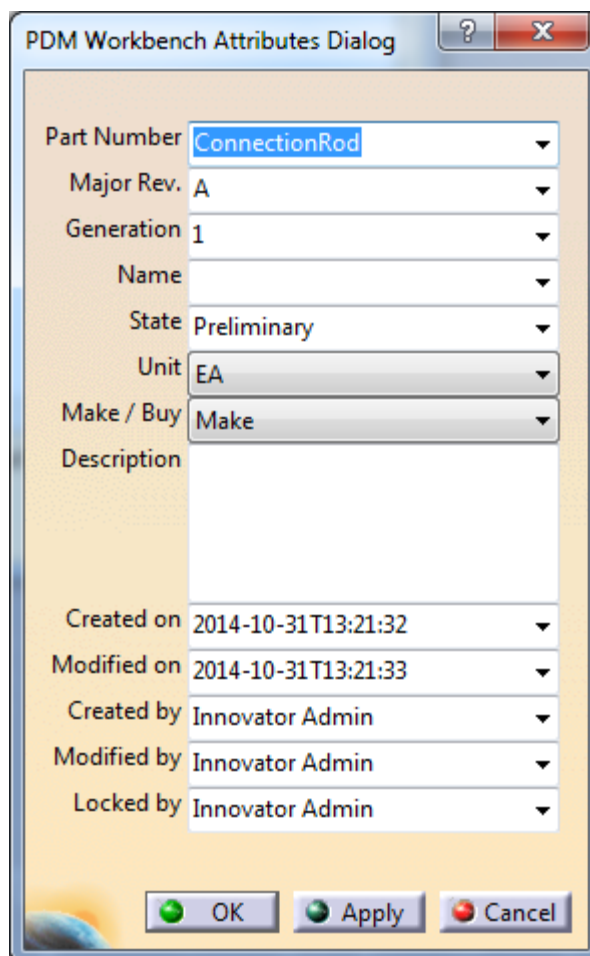

Picture 412: Dialog with pre-filled attributes

Glossary

Unclaim

Action withdrawing the right to update a work item. Normally this corresponds with publishing the work item to a larger number of people getting read access on this object.

Claim

Action giving the user the exclusive right to update a work item.

Context Menu

The menu that appears when the user selects an *icon* and holds the right mouse button pressed.

Dialog Window

Window in which the user enters information.

GII

Graphics Interactive Interface. The GII is a powerful programming tool, which completes the Open System Access to the CATIA environment.

Icon

Graphical representation of an *object*.

Object

An item or a relationship.

Query

To search the database for *objects* that match specific criteria.