



PDM-Workbench

PDM-Workbench Release 3.2 for Aras Innovator

User Manual



Copyright

© 2005-2012 T-Systems International GmbH.

All rights reserved. Printed in Germany.

Contact

T-Systems International GmbH
PDC PLM
Fasanenweg 5
70771 Leinfelden-Echterdingen
Germany

<http://www.pdm-workbench.com>

☎ +49-711-972-4 96 57

✉ +49-711-972-9 59 75

mail : cmi_support@t-systems.com

Manual History

Version	Date
1.0	March 2005
1.1	August 2005
1.2	December 2005
2.0	November 2006
2.1	March 2008
2.2	September 2008
2.5	March 2011
3.0	October 2011
3.1	February 2012
3.1 SR1	February 2012
3.2	March 2012

This edition obsoletes all previous editions.

Your Comments are Welcome

Please feel free to tell us your opinion; we are always interested in improving our publications. Mail your comments to:

T-Systems International GmbH PDC PLM Fasanenweg 5 70771 Leinfelden-Echterdingen Germany mail: cmi_support@t-systems.com

Preface

About this Manual

This manual describes the main functionality delivered by the PDM-Workbench.

The functionality of the PDM-Workbench as described in this manual uses Aras Innovator as backend PDM system for CATIA V5.

Other PDM systems might support the functionality of the PDM-Workbench with their own types of objects. Layout of dialogs as well as object and relation types or classes might vary accordingly.

This manual is intended for end users of the PDM-Workbench.

It assumes that the reader is familiar with the CATIA application and with Aras Innovator.

Related Documents

The following manuals contain information about installation, administration, usage, and customization of the *PDM-Workbench*:

Manual Title	Version
<i>PDM-Workbench Installation & Administration Manual</i>	3.2
<i>PDM-Workbench User Manual</i>	3.2

Organization

This manual contains the following chapters:

Chapter 1 provides basic information about the PDM-Workbench and describes some features of this application.

Chapter 2 describes the supported data models.

Chapter 3 describes the functionality which is implemented in the CATIA V5 workshop.

Glossary contains the PDM-Workbench terminology.

Trademarks

CATIA is a registered trademark of Dassault Systèmes.

Aras is a registered trademark of Aras Corporation.

Names of other products mentioned in this manual are used for identification purpose only and might be trademarks of their companies.

Table of Contents

CHAPTER 1	1
OVERVIEW	1
INTRODUCING PDM-WORKBENCH.....	1
CHAPTER 2	3
SUPPORTED DATA MODELS	3
BOM PART STRUCTURE DATA MODEL.....	3
DOCUMENT DATA MODEL.....	3
CHAPTER 3	5
GETTING STARTED	5
LOGIN.....	5
QUERY.....	6
EXPAND SINGLE LEVEL.....	9
EXPAND MULTIPLE LEVELS.....	10
DE-EXPAND.....	11
PROPERTIES.....	14
LOCK.....	17
<i>Lock of the Part in the PDM-Workbench window</i>	17
<i>Lock of the object in the Query dialog</i>	19
<i>Lock of the Document in the CATIA V5 window</i>	20
UNLOCK.....	21
<i>Unlock of the Part in the PDM-Workbench window</i>	21
<i>Unlock of the object in the Query dialog</i>	23
<i>Unlock of the Document in the CATIA V5 window</i>	24
PROMOTE.....	24
REVISE.....	26
UPDATE STRUCTURE RELATIONS.....	28
DELETE.....	30
DELETE NEWEST VERSION.....	31
OPEN FILE.....	33
OPEN FILE TEMPORARY.....	35
LOAD.....	38
ADD TEMP.....	39
DUPLICATE.....	42
CREATE RELATION BETWEEN WINDOWS.....	45
UPDATE.....	48
SHOW PDM STRUCTURE.....	50
REFRESH PDM STRUCTURE.....	50
FORCE LOAD CATPART.....	53
HIGHLIGHT PDM NODES.....	53
HIGHLIGHT CATIA NODES.....	54
OPEN IN NEW WINDOW.....	55
ATTRIBUTE MAPPING FUNCTIONALITY.....	56
INTERNAL CATIA INFORMATION CAN BE WRITTEN TO USER-DEFINED CATIA PROPERTIES ...	61
TEMPLATE-BASED CAD DOCUMENT AND PART CREATION.....	62
COPY ELEMENT ATTRIBUTES.....	64
CATIA DOCUMENTS ARE SET TO READ-ONLY IF CORRESPONDING PDM NODE IS NOT MODIFIABLE.....	65
ADDED CHECK WHETHER CATIA STRUCTURE IS VALID BEFORE UPDATE.....	66
THUMBNAILS.....	66
PDM SESSION CONFIGURATION.....	67
LOGOUT.....	67
OPTIONS.....	67

<i>Query Mode</i>	68
<i>PDM Relations</i>	69
<i>CATDrawings</i>	70
<i>Loading PDM Structures</i>	70
GLOSSARY	71

Table of Figures

PICTURE 1: PDM-WORKBENCH WORKSHOP IN CATIA V5.....	1
PICTURE 2: STRUCTURE IN THE BOM PART STRUCTURE DATA MODEL.....	3
PICTURE 3: STRUCTURE IN THE DOCUMENT DATA MODEL	4
PICTURE 4: THE PDM-WORKBENCH TOOLBAR BEFORE THE LOGIN	5
PICTURE 5: "LOGIN" DIALOG.....	5
PICTURE 6: THE PDM-WORKBENCH TOOLBAR AFTER THE LOGIN.....	6
PICTURE 7: THE PDM-WORKBENCH CONTEXT COMMANDS TOOLBAR	6
PICTURE 8: "PDM QUERY" DIALOG	7
PICTURE 9: "PDM QUERY" DIALOG – ENTER QUERY CRITERIA.....	7
PICTURE 10: "PDM QUERY" DIALOG – FOUND OBJECTS	8
PICTURE 11: "PDM QUERY" DIALOG – ACTION "OPEN IN NEW WINDOW"	8
PICTURE 12: QUERY RESULT IN PDM STRUCTURE WINDOW	8
PICTURE 13: ACTION "EXPAND SINGLE LEVEL"	9
PICTURE 14: RESULT OF EXPAND SINGLE LEVEL.....	9
PICTURE 15: RESULT OF EXPAND SINGLE LEVEL WITHOUT RELATIONS	10
PICTURE 16: ACTION "EXPAND MULTIPLE LEVELS"	10
PICTURE 17: RESULT OF EXPAND MULTIPLE LEVELS	11
PICTURE 18: PDM STRUCTURE BEFORE THE DE-EXPAND	12
PICTURE 19: ACTION "DE-EXPAND"	13
PICTURE 20: PDM STRUCTURE AFTER THE DE-EXPAND.....	14
PICTURE 21: ACTION "PROPERTIES"	15
PICTURE 22: "PROPERTIES" DIALOG – TAB "PROPERTIES"	16
PICTURE 23: "PROPERTIES" DIALOG – TAB "UPDATE ITEM"	17
PICTURE 24: ACTION "LOCK"	18
PICTURE 25: CONFIRM THE LOCK OF THE PART.....	18
PICTURE 26: OBJECT IS LOCKED	19
PICTURE 27: LOCKED OBJECT	19
PICTURE 28: ACTION "LOCK" IN THE QUERY RESULT LIST	20
PICTURE 29: ACTION "LOCK" IN THE CATIA V5 WINDOW	20
PICTURE 30: ACTION "UNLOCK"	21
PICTURE 31: CONFIRM THE UNLOCK OF THE PART	22
PICTURE 32: OBJECT IS UNLOCKED	22
PICTURE 33: UNLOCKED OBJECT	23
PICTURE 34: ACTION "UNLOCK" IN THE QUERY RESULT LIST	23
PICTURE 35: ACTION "UNLOCK" IN THE CATIA V5 WINDOW.....	24
PICTURE 36: ACTION "PROMOTE"	25
PICTURE 37: CONFIRM THE "PROMOTE" ACTION	25
PICTURE 38: OBJECT IS PROMOTED	26
PICTURE 39: ACTION "REVISE"	27
PICTURE 40: CONFIRM THE "REVISE" ACTION	27
PICTURE 41: OBJECT IS REVISED	28
PICTURE 42: ACTION "UPDATE STRUCTURE RELATIONS"	29
PICTURE 43: UPDATED STRUCTURE RELATIONS	30
PICTURE 44: ACTION "DELETE"	30
PICTURE 45: CONFIRM DELETE OBJECTS	31
PICTURE 46: DELETE RESULT WINDOW	31
PICTURE 47: ACTION "DELETE NEWEST VERSION".....	32
PICTURE 48: CONFIRM DELETE NEWEST VERSION.....	32
PICTURE 49: DELETE NEWEST VERSION RESULT WINDOW.....	33
PICTURE 50: RE-EXPAND OF THE DOCUMENT	33
PICTURE 51: ACTION "OPEN FILE"	34
PICTURE 52: OPEN FILE - PROGRESS BAR	34
PICTURE 53: SPLIT WINDOW AFTER OPEN FILE – PDM-WORKBENCH NODE AND CATIA DRAWING	35
PICTURE 54: ACTION "OPEN FILE".....	36
PICTURE 55: CURRENT FILE.....	36

PICTURE 56: ACTION "OPEN FILE TEMPORARY"	37
PICTURE 57: TEMPORARY OPENED FILE.....	37
PICTURE 58: ACTION "LOAD"	38
PICTURE 59: LOAD - PROGRESS BAR	38
PICTURE 60: SPLIT WINDOW AFTER LOAD – PDM-WORKBENCH AND CATIA V5 NODES	39
PICTURE 61: ACTION "LOAD"	40
PICTURE 62: LOADED GEOMETRY FOR REVISION "B"	40
PICTURE 63: ACTION "ADD TEMP"	41
PICTURE 64: LOADED GEOMETRY FOR REVISION "A"	41
PICTURE 65: ACTION "DUPLICATE".....	42
PICTURE 66: "PDM CREATE" DIALOG FOR DUPLICATE	42
PICTURE 67: FILLED "PDM CREATE" DIALOG FOR DUPLICATE.....	43
PICTURE 68: DUPLICATED CATPRODUCT OBJECT	43
PICTURE 69: "PDM CREATE" DIALOG FOR ASSEMBLY AND CATPRODUCT	44
PICTURE 70: FILLED "PDM CREATE" DIALOG FOR ASSEMBLY AND CATPRODUCT	44
PICTURE 71: "PDM CREATE" DIALOG FOR ASSEMBLY AND CATDRAWING	45
PICTURE 72: DUPLICATED CATPRODUCT OBJECT	45
PICTURE 73: ACTION "COPY" BETWEEN WINDOWS	46
PICTURE 74: ACTION "PASTE" BETWEEN WINDOWS	47
PICTURE 75: SELECT THE NEW RELATION	47
PICTURE 76: PRODUCT STRUCTURE WITH INSERTED OBJECT	48
PICTURE 77: CONFIRM THE UPDATE (WITH CREATE) ACTION	48
PICTURE 78: PROGRESS BARS FOR UPDATE ACTION	49
PICTURE 79: INFORMATION WINDOW WHEN UPDATE (WITH CREATE) IS FINISHED	49
PICTURE 80: CONFIRM THE UPDATE ACTION.....	49
PICTURE 81: INFORMATION WINDOW WHEN UPDATE IS FINISHED.....	50
PICTURE 82: PDM STRUCTURE FOR GEOMETRY.....	50
PICTURE 83: PDM STRUCTURE AND GEOMETRY IN CATIA V5	51
PICTURE 84: MAKING CHANGES IN THE GEOMETRY	52
PICTURE 85: REFRESHED PDM STRUCTURE.....	52
PICTURE 86: ACTION "FORCE LOAD CATPART".....	53
PICTURE 87: ACTION "HIGHLIGHT PDM NODES".....	54
PICTURE 88: HIGHLIGHTED NODES IN PDM STRUCTURE	54
PICTURE 89: ACTION "HIGHLIGHT CATIA NODES"	55
PICTURE 90: HIGHLIGHTED NODES IN CATIA GEOMETRY	55
PICTURE 91: ACTION "OPEN IN NEW WINDOW"	56
PICTURE 92: THE SELECTED OBJECTS IN THE NEW WINDOW	56
PICTURE 93: STANDARD ATTRIBUTES IN THE "PROPERTIES" DIALOG.....	57
PICTURE 94: CONFIGURATION OF STANDARD ATTRIBUTES IN ARAS INNOVATOR.....	57
PICTURE 95: STANDARD ATTRIBUTES IN THE "PROPERTIES" DIALOG OF THE PDM NODE	58
PICTURE 96: STANDARD ATTRIBUTES IN ARAS INNOVATOR WINDOW	58
PICTURE 97: CONFIGURATION OF USER-DEFINED ATTRIBUTES IN ARAS INNOVATOR.....	59
PICTURE 98: USER-DEFINED ATTRIBUTES IN THE "PROPERTIES" DIALOG OF THE PDM NODE ...	59
PICTURE 99: USER-DEFINED ATTRIBUTES IN ARAS INNOVATOR WINDOW	60
PICTURE 100: USER-DEFINED ATTRIBUTES IN THE "PROPERTIES" DIALOG	60
PICTURE 101: USER-DEFINED ATTRIBUTES WITH INTERNAL CATIA INFORMATION IN THE "PROPERTIES" DIALOG.....	61
PICTURE 102: CONFIGURATION OF USER-DEFINED ATTRIBUTES IN ARAS INNOVATOR.....	62
PICTURE 103: SELECT A PDM TYPE FOR THE "CREATE" DIALOG.....	62
PICTURE 104: "CREATE" DIALOG FOR CATPART – SELECT TEMPLATE.....	63
PICTURE 105: "CREATE" DIALOG FOR CATPART.....	63
PICTURE 106: CREATED PART	63
PICTURE 107: ACTION "COPY ELEMENT ATTRIBUTES".....	64
PICTURE 108: "CREATE" DIALOG FOR ASSEMBLY	65
PICTURE 109: "CREATE" DIALOG FOR ASSEMBLY- INSERTED ATTRIBUTE VALUES	65
PICTURE 110: SAVE MANAGEMENT	66
PICTURE 111: CHECK IF CATIA STRUCTURE IS VALID	66
PICTURE 112: CAD DOCUMENT PROPERTIES IN ARAS INNOVATOR	66
PICTURE 113: THE PDM-WORKBENCH TOOLBAR AFTER THE LOGIN.....	67
PICTURE 114: THE PDM-WORKBENCH OPTIONS	68
PICTURE 115: "CUSTOMIZE LIST VIEW" DIALOG	68
PICTURE 116: "CUSTOMIZE LIST VIEW" DIALOG - FOR "ASSEMBLY".....	69

PICTURE 117: PREVIEW OF THE "LIST VIEW" DIALOG..... 69

CHAPTER 1

Overview

This chapter provides basic information about the *PDM-Workbench* and lists some features of this application.

Introducing PDM-Workbench

The *PDM-Workbench* is developed by T-Systems as a high-end integration between the CAD system *CATIA V5* and several PDM systems. Those PDM systems might be customized or virtual (a combination of several PDM systems). No matter which type they are the *PDM-Workbench* will integrate them into *CATIA V5*. How those PDM object types are to present their dialogs and functionalities within the *PDM-Workbench* is defined in a configuration file (called *PDM-Workbench Schema File*).

The *PDM-Workbench* workshop works with two different windows. The first window type presents the results of your queries. There you also might expand your product structure. Or you can create new objects in this window.

You can load this product structure into a *CATIA V5* native window, and you can modify the content of this *CATIA V5* native window (see *Picture 1: PDM-Workbench workshop in CATIA V5*).

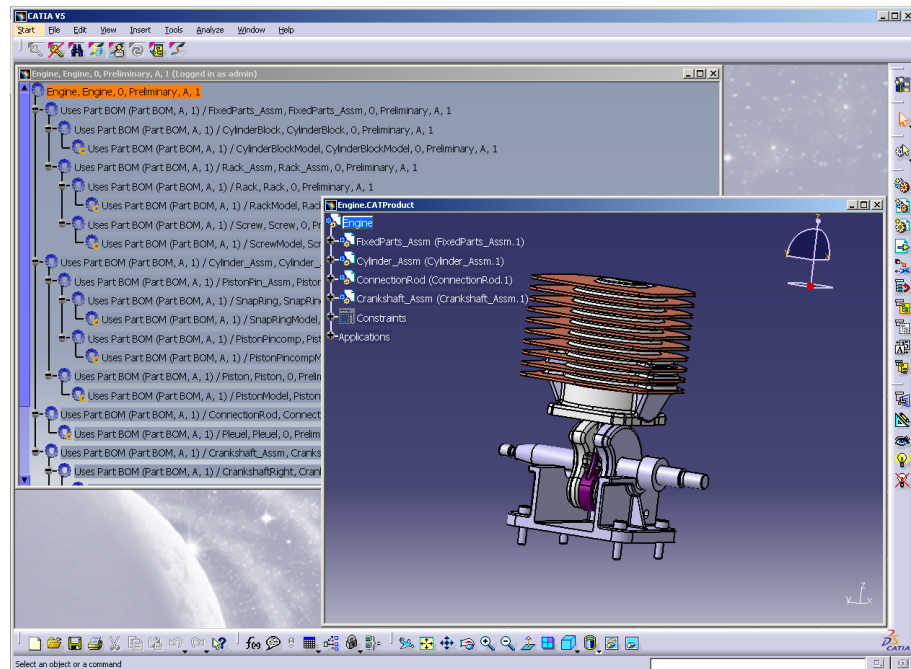

Picture 1: PDM-Workbench workshop in CATIA V5

CHAPTER 2

Supported Data Models

The PDM-Workbench supports two different data models.

BOM Part Structure data model

In the BOM Part Structure data model the PDM structure is represented by Parts (Assembly or Component). The relation "Part BOM" is used.

Each Part is described by a CAD Document which includes the CATIA file for a CATProduct, CATPart, or CATDrawing (see *Picture 2: Structure in the BOM Part Structure data model*).

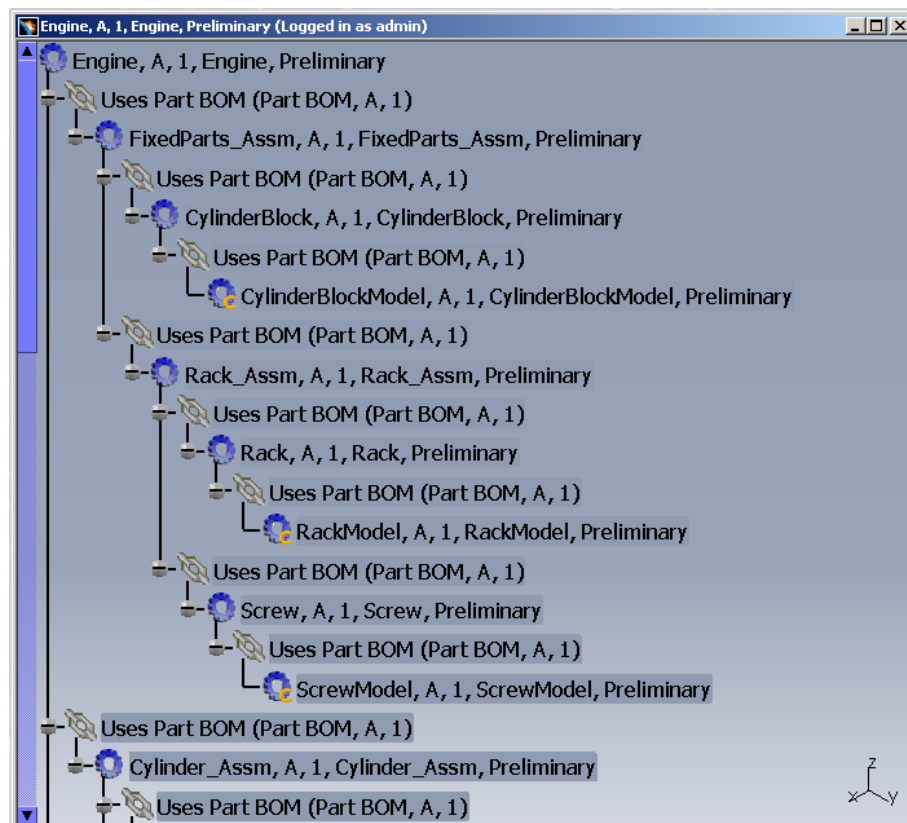

Picture 2: Structure in the BOM Part Structure data model

Document data model

In the document data model the PDM structure is represented by CAD Documents. The relation "CAD Structure" is used.

Each CAD Document which includes the CATIA file for a CATProduct, CATPart, or CATDrawing (see *Picture 3: Structure in the document data model*)

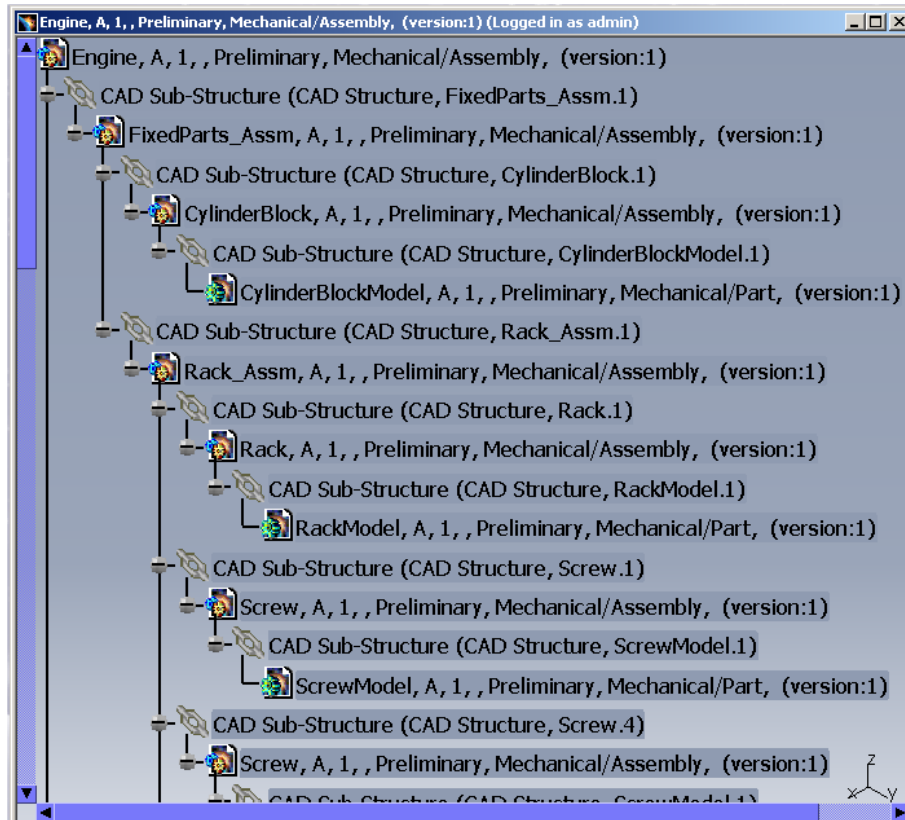

Picture 3: Structure in the document data model

CHAPTER 3

Getting Started

This chapter describes the functionality of the PDM-Workbench which is implemented in the CATIA V5 workshop.

We suppose that you have installed CATIA V5 with the PDM-Workbench workshop on your computer. All configurations for the PDM-Workbench (including the configurations for the PDM system) are done properly.

Note: All user actions described below are based on the corresponding configuration of the data model and the actions to be provided by the PDM system.

Login

In order to access the PDM-Workbench functionality you must log in into the PDM system.

You select the “Login” icon  within the PDM-Workbench toolbar (see *Picture 4: The PDM-Workbench toolbar before the login*) in CATIA V5. The other PDM-Workbench icons remain deactivated.



Picture 4: The PDM-Workbench toolbar before the login

The following dialog (see *Picture 5: “Login” dialog*) prompts you for all information necessary to identify yourself in the PDM system. In our example you are asked to enter your “User Name”, “Password”, and “Database”. The identification items marked with an asterisk are defined as necessary for Login in the PDM-Workbench configuration file.



Picture 5: “Login” dialog

Click the “Login” button.

Once the login action was successful most of the icons in the PDM-Workbench toolbar will turn active while some will remain inactive as they depend on further user actions to be done to get them available (see *Picture 6: The PDM-Workbench toolbar after the login*).

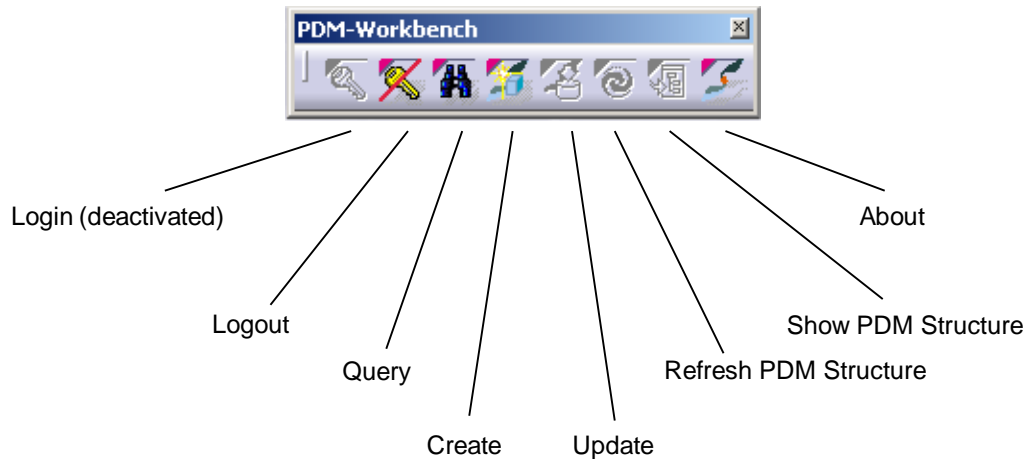

Picture 6: The PDM-Workbench toolbar after the login

For CATPart and CATDrawing as top level object of the CATIA V5 window you have to use the actions “PDM Properties”, “Unlock”, “Lock”, and “Duplicate” of the “PDM-Workbench context commands” toolbar (see *Picture 7: The PDM-Workbench context commands toolbar*). The icons in this toolbar are only repainted (e.g. switch from “Lock” to “Unlock”) when you newly activate the CATIA V5 window.

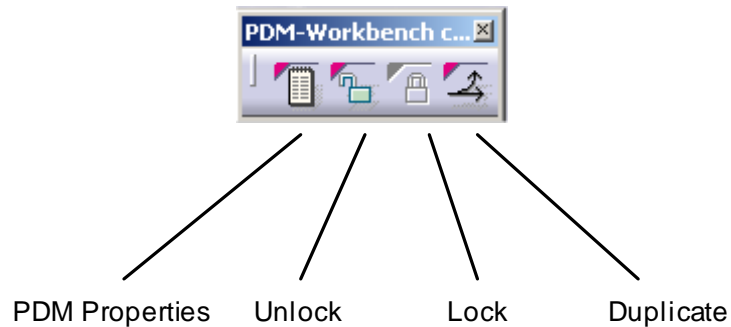

Picture 7: The PDM-Workbench context commands toolbar

Query

You can query for any object stored in the PDM system.

Once you click the “Query” icon  in the PDM-Workbench toolbar the query dialog opens. On the left side of the dialog you can define the query criteria. On the right side you will see the query results (see *Picture 8: “PDM Query” dialog*).

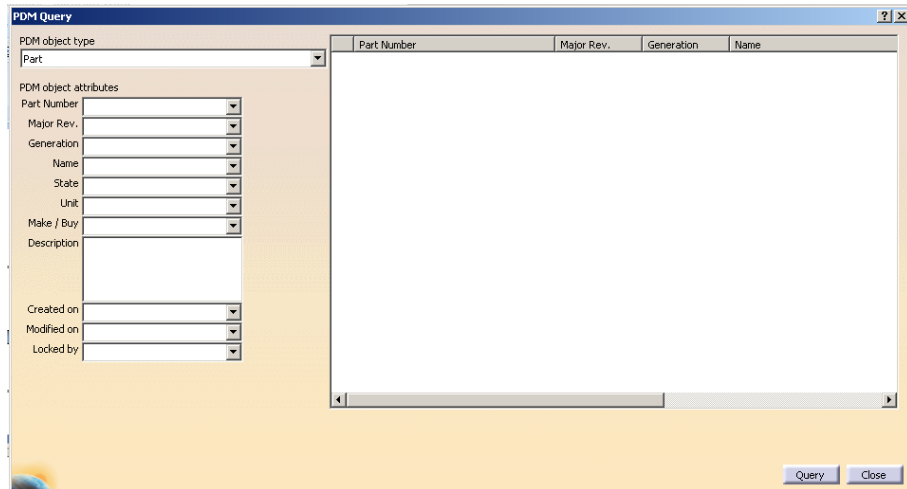

Picture 8: “PDM Query” dialog

The query criteria are defined by the type and the attributes for this type. A default type is selected and its attributes are shown.

You can select a type in the single selector list in the first line. The attributes will be shown automatically.

Specify your selection criteria in the lines below.

You can use the wildcard “*” in this dialog. All attributes visible in this dialog are attributes of the PDM system for the selected object type. (These attributes as well as their adherence to the “Query” dialog of this type are defined in the PDM-Workbench configuration file).

Some attribute values can be keyed in as free text while for others a value might be selected from a list.

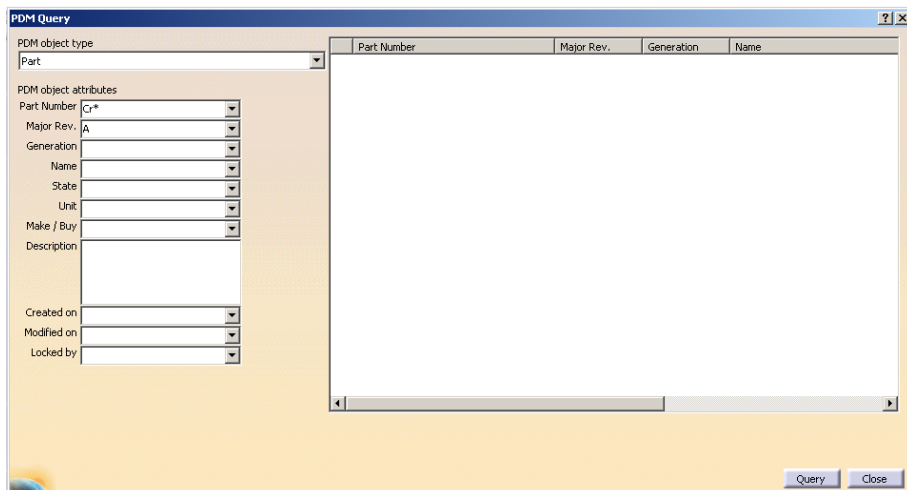

Picture 9: “PDM Query” dialog – enter query criteria

When you have specified the selection criteria you can start the query for PDM objects with a click on the “Query” button.

In the settings of the PDM-Workbench you can define the columns for the query result on the right side of the dialog (see chapter *Options - Query Mode*).

The found objects will be presented on the right side of the dialog. By clicking on the column name you can sort the query result (see *Picture 10: “PDM Query” dialog – found objects*).

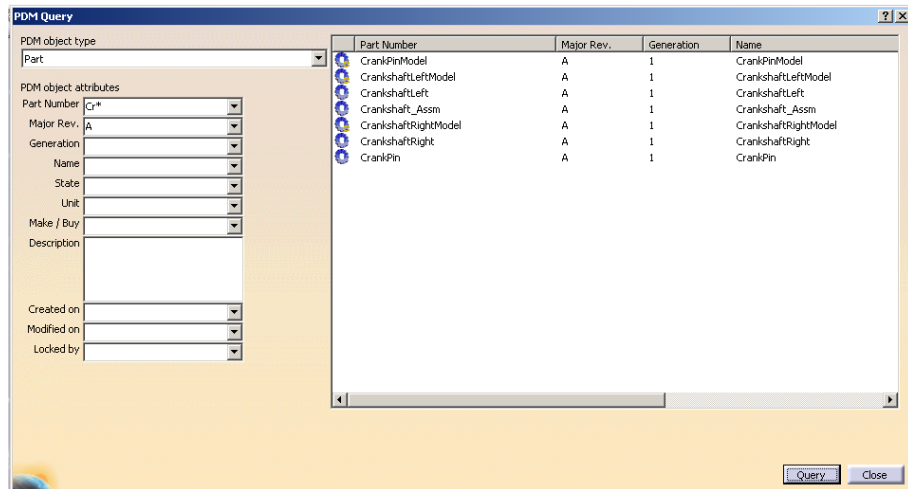

Picture 10: “PDM Query” dialog – found objects

There you can select the object or the objects to be opened in a new PDM-Workbench window. Click on the right mouse button and select “Open in New Window”.

A double click on a single object opens it in a new PDM-Workbench window (see *Picture 11: “PDM Query” dialog – Action “Open in New Window”*).

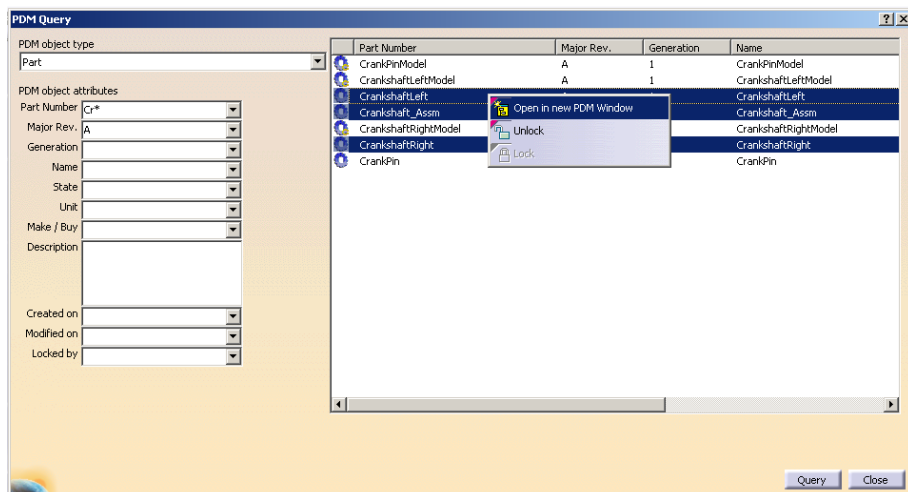

Picture 11: “PDM Query” dialog – Action “Open in New Window”

Now you can close the query dialog by clicking on the “Close” button.

The found objects are opened in the PDM-Workbench window now (see *Picture 12: Query result in PDM Structure window*).

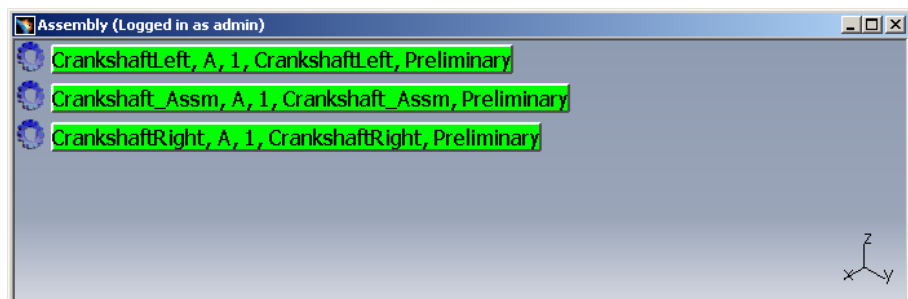

Picture 12: Query result in PDM Structure window

Expand Single Level

You can expand from the selected object to other related objects via several relations in two directions.

Select the object from which you want to expand and open the context menu by clicking on the right mouse button. Select the context action “Expand”. The “Expand” sub menu offers the possible relation directions for expansion from the selected object.

In the example in *Picture 13: Action “Expand Single Level”* you select the direction “Uses Part BOM” for the selected “Assembly” object “Engine”.

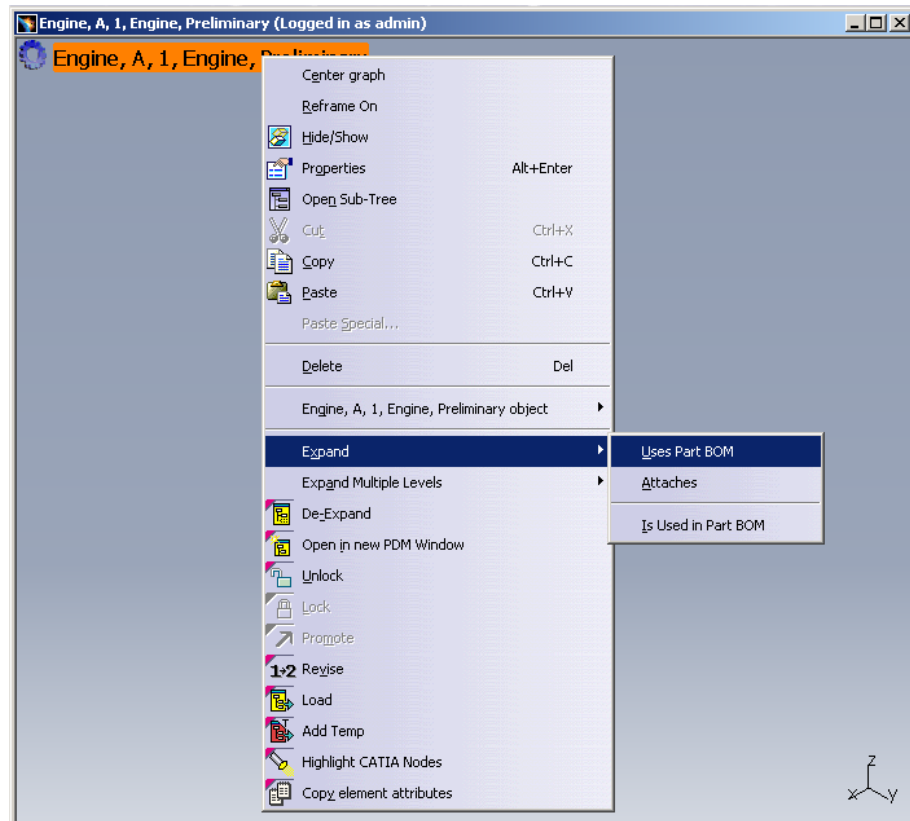

Picture 13: Action “Expand Single Level”

The related objects for the selected “Assembly” object “Engine” are shown in *Picture 14: Result of expand single level*.

In the product structure tree you can see the objects and relations. The type of the relation is displayed in braces in the line of the relation.



Picture 14: Result of expand single level

When you have switched off the display of the relations in the options (see *Options - PDM Relations*) then the expand tree looks like displayed in *Picture 15: Result of expand single level without relations*.

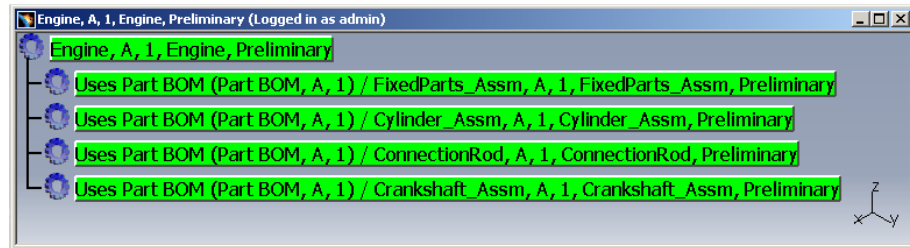

Picture 15: Result of expand single level without relations

The type of the relation, the revision, and the generation of the relation are displayed in the braces in the line of the relation. The attributes can be configured in the PDM-Workbench Schema File.

Expand Multiple Levels

You also might expand a relation direction in multiple levels from the selected object.

Select the object from which you want to expand and open the context menu by clicking on the right mouse button. Select the context action “Expand Multiple Levels”. The “Expand Multiple Levels” sub menu offers the possible relation directions for expansion from the selected object.

In the example in *Picture 16: Action “Expand Multiple Levels”* you select the direction “Uses Part BOM” for the selected “Assembly” object “Engine”.

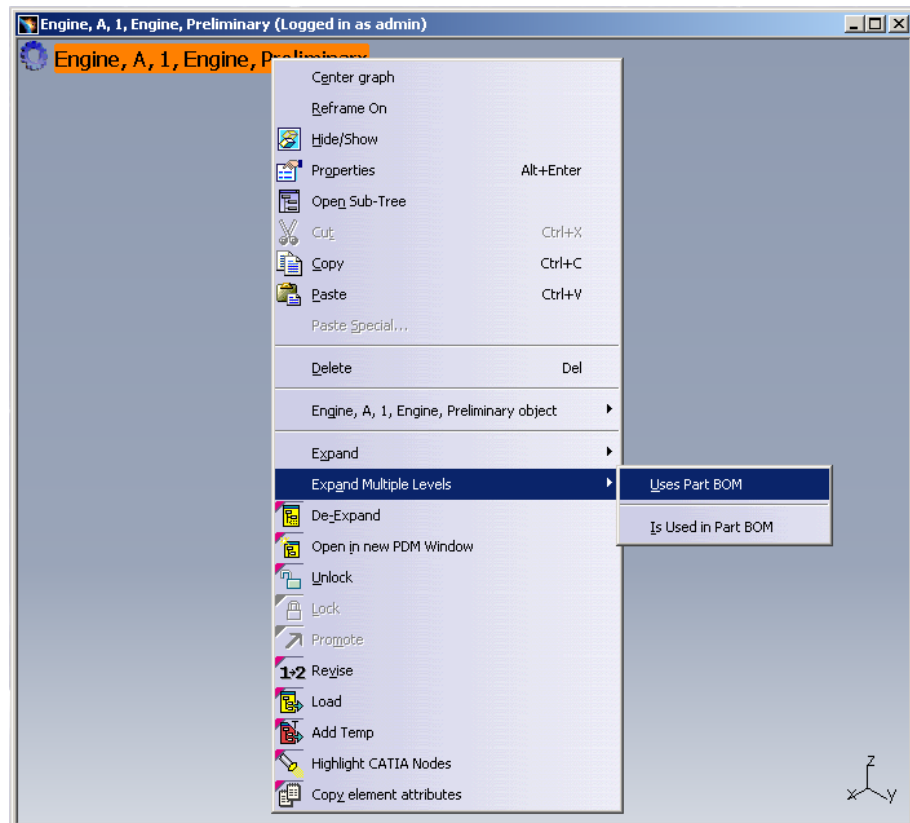

Picture 16: Action “Expand Multiple Levels”

The related objects in multiple levels are shown for the selected “Assembly” object “Engine” in *Picture 17: Result of expand multiple levels*.

In the product structure tree you can see the objects and relations. The type of the relation, the revision, and the generation are displayed in braces in the line of the relation.

When you have switched off the display of the relations in the options (see *Options - PDM Relations*) then the relation objects will not be displayed in the expanded product structure tree.

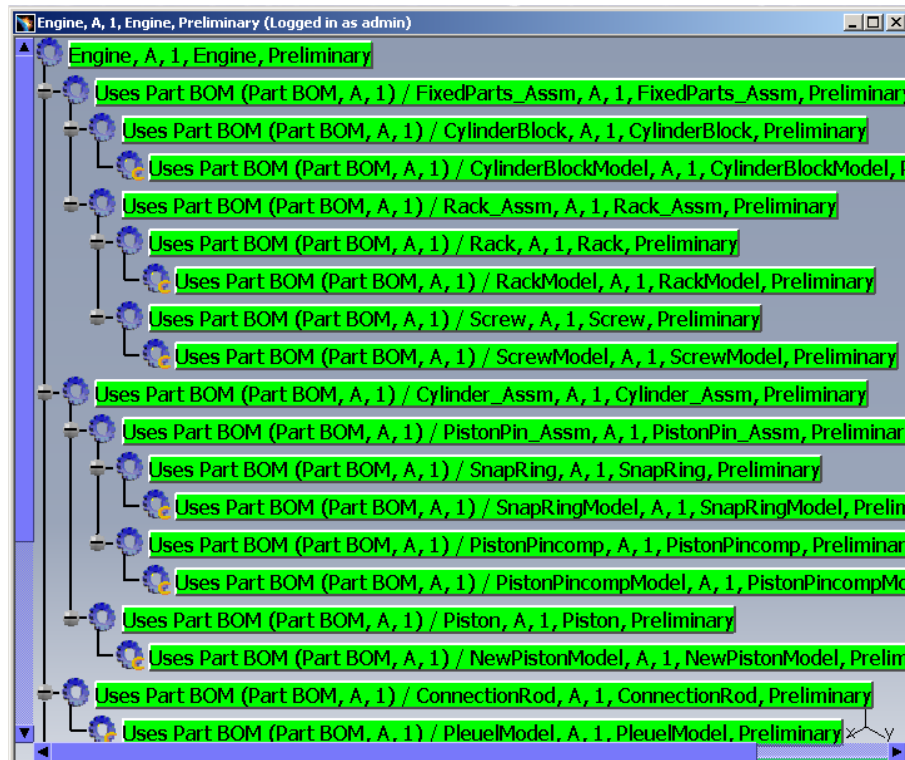

Picture 17: Result of expand multiple levels

De-Expand

When you want to reduce the displayed PDM structure then you can de-expand parts of the structure.

In *Picture 18: PDM structure before the De-Expand* you can see the PDM structure before the de-expand.

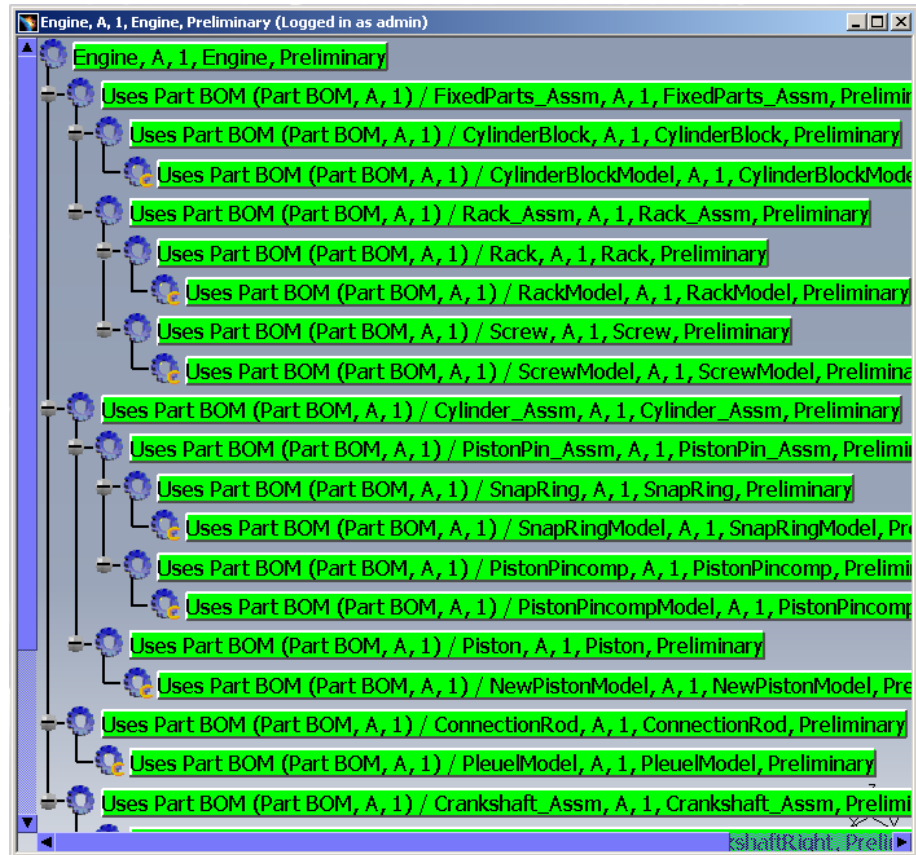

Picture 18: PDM structure before the De-Expand

First you select the root element of the sub structure which you want to de-expand. You also might de-expand a single object. Then you open the context menu by clicking the right mouse button and you select the action “De-Expand”.

In the example in *Picture 19: Action “De-Expand”* you select the object “FixedParts_Assm” as root of the sub structure to be de-expanded.

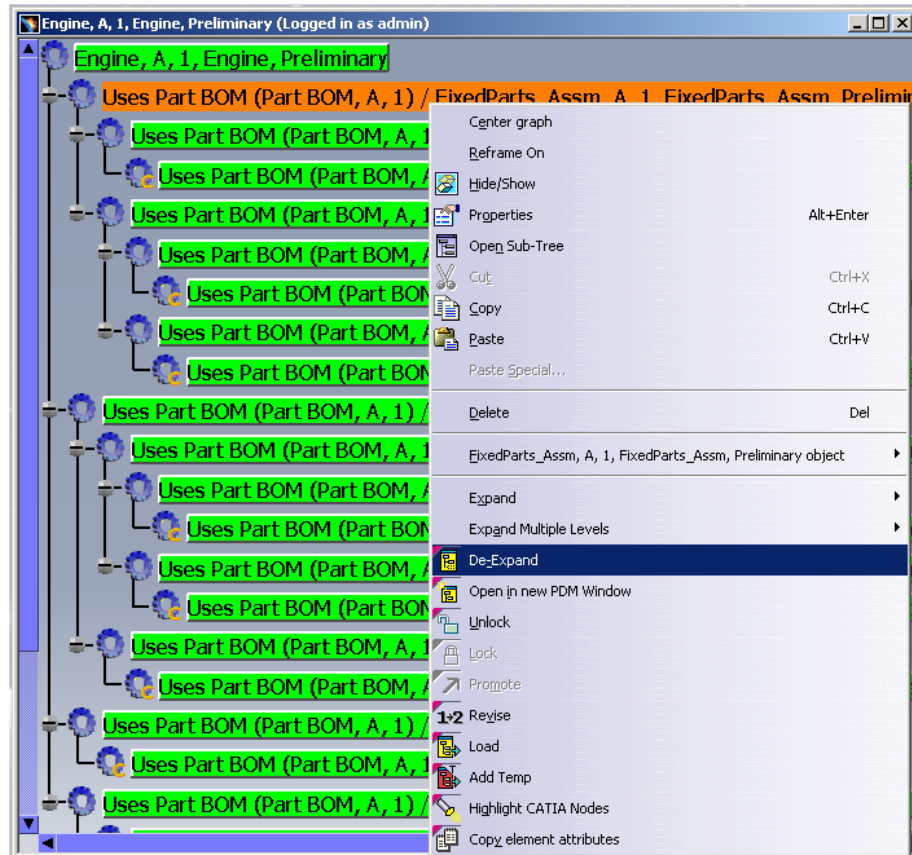

Picture 19: Action “De-Expand”

In *Picture 20: PDM structure after the De-Expand* you see that the selected sub structure with the root element “FixedParts_Assm” is de-expanded as it is no longer displayed in the PDM structure.

But remember that the PDM structure will not be modified by this de-expand. The sub structure will not be deleted from the PDM structure.

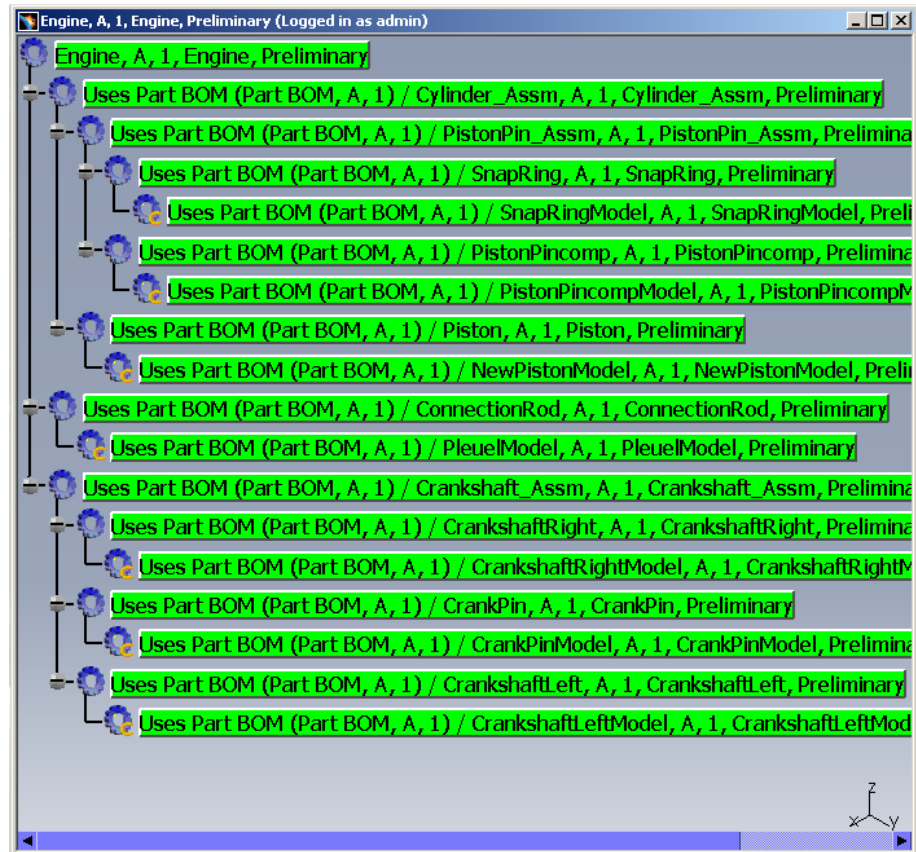

Picture 20: PDM structure after the De-Expand

Properties

The PDM properties of the objects in the PDM-Workbench window are transferred from the PDM system when the objects are displayed in the PDM-Workbench window for the first time, e.g. when they are shown as a result of a query or an expand action.

You take a look at those properties and/or change these properties when opening the “Properties” dialog. Therefore click on the right mouse button. Now the context menu opens and you select the action “Properties” (see *Picture 21: Action “Properties”*).

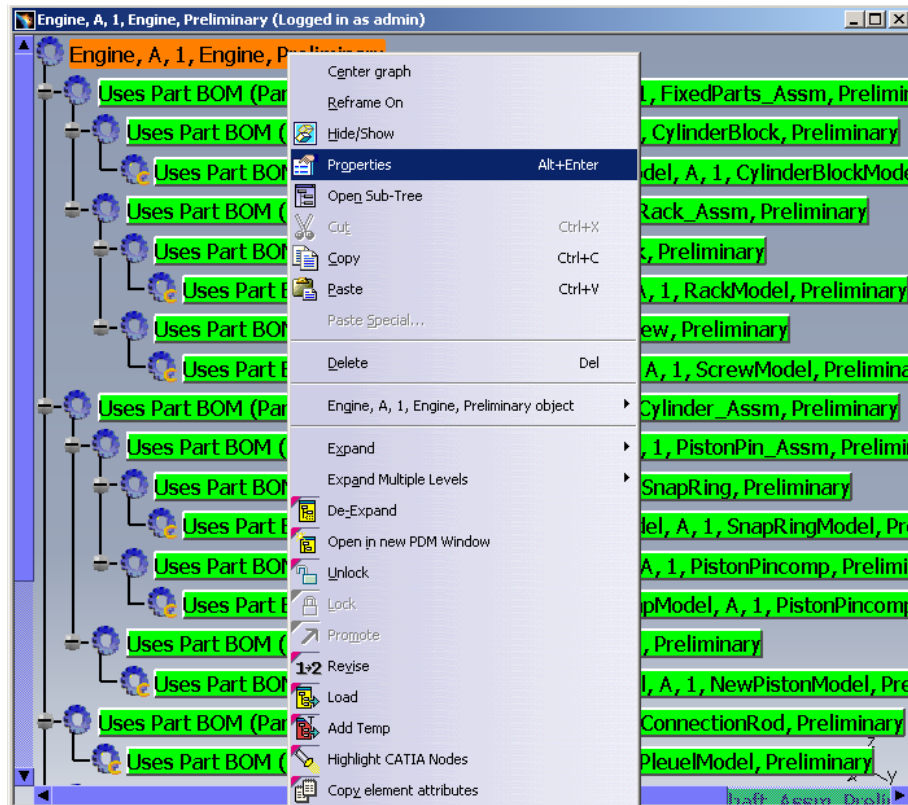

Picture 21: Action “Properties”

The “Properties” dialog will be opened (see *Picture 22: “Properties” dialog – tab “Properties”*). It consists of two tabs.

In the tab “Properties” the values of the attributes are shown on a grey background. This indicates that the values cannot be changed. All properties that are shown within this dialog can be specified within the PDM-Workbench Schema File.

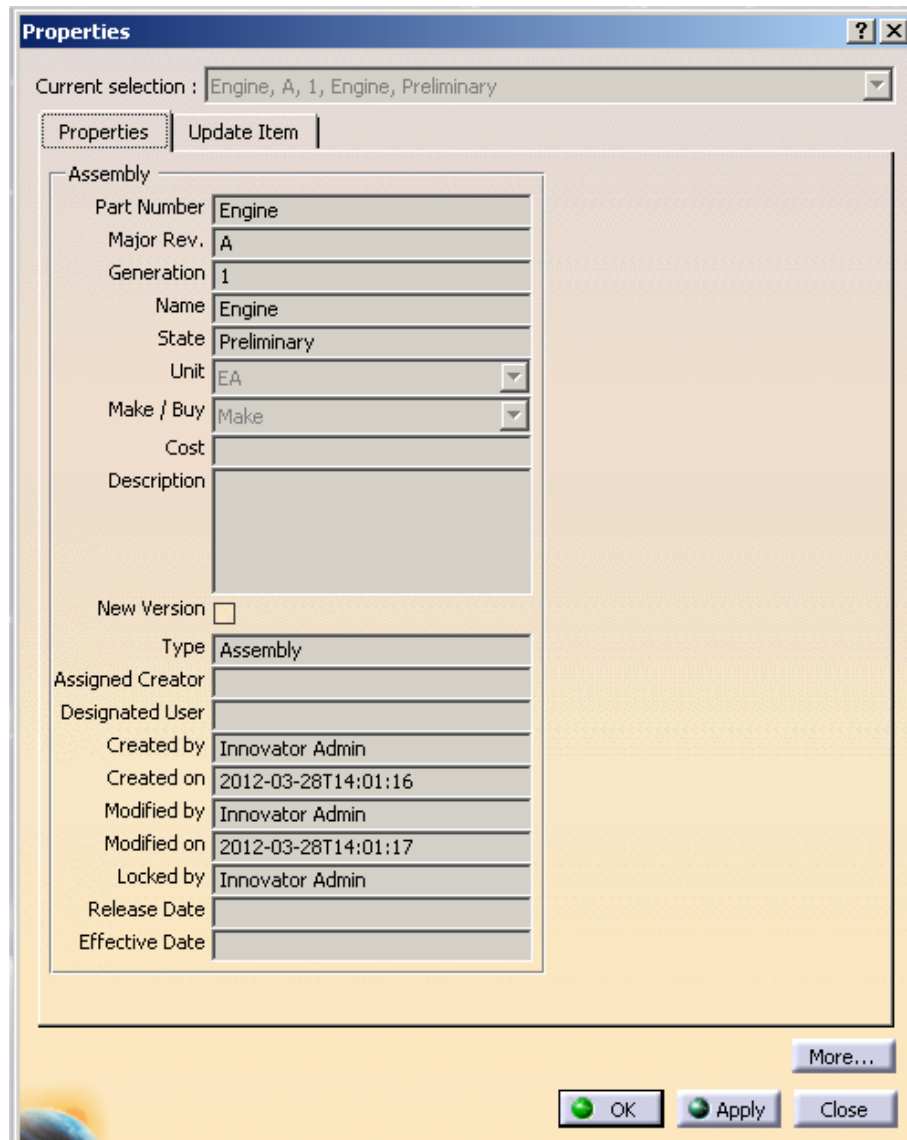

Picture 22: “Properties” dialog – tab “Properties”

In the tab “Update Item” those attribute values shown on a grey background cannot be changed. Those presented with the white background can be changed (see *Picture 23: “Properties” dialog – tab “Update Item”*).

Required attributes are marked with an asterisk (*) on the right side of the input field.

There are several types of attributes presented on corresponding widgets:

- Free text can be inserted.
- One value can be selected in a single selector list or combo box for instance or any other widget.
- Multiple values can be selected in a multi selector list or other widget types supporting this feature.
- The value can be marked or unmarked in a check box for instance.

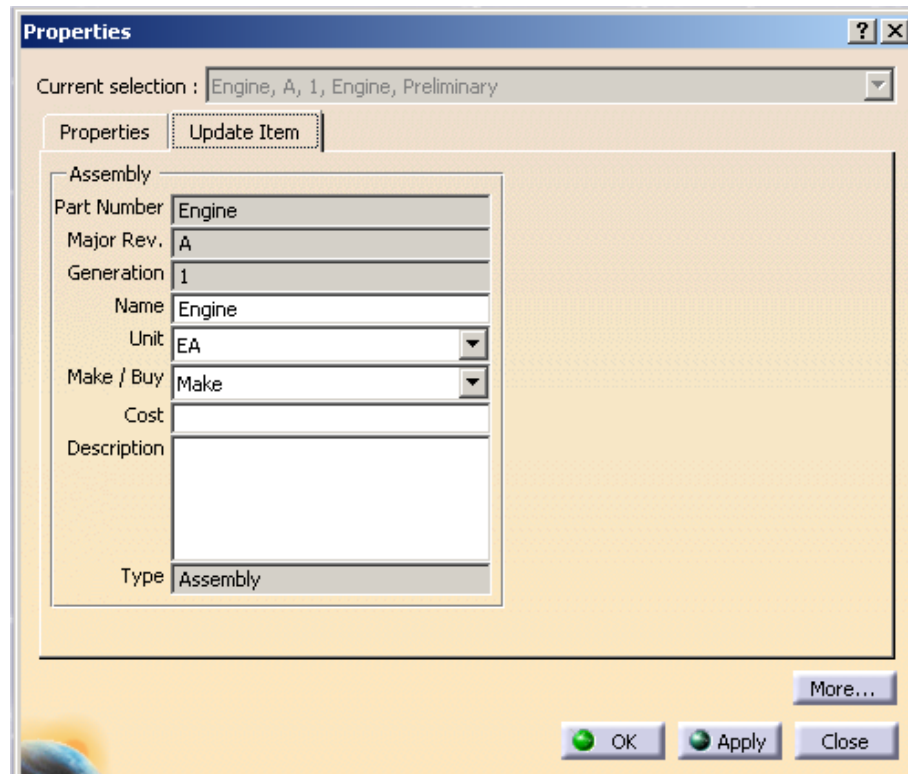

Picture 23: “Properties” dialog – tab “Update Item”

Please use the “OK” button to close the “Properties” dialog.

In the tab “Update Item” the required attributes get checked for being satisfied. If not you will get an error window that describes your fault.

The object gets updated in the PDM system database according to the Update dialog values. When the update is not possible in the PDM system (because of a wrong value of an attribute or different reasons) then you will get an error window.

The PDM system properties of a CATPart and CATDrawing as top level object of the CATIA V5 window cannot be inspected with the context menu. You have to use the “PDM

Properties” button  of the “PDM-Workbench context commands” toolbar. The values of the attributes are in read-only mode. You are not able to make changes on the PDM system attributes in this dialog.

Lock

Lock of the Part in the PDM-Workbench window

You have to lock the PDM objects prior to changing and updating them.

So you select the object in the PDM-Workbench window and click the right mouse button. In the context menu you select the context action “Lock” (see *Picture 24: Action “Lock”*). This action is only active in the context menu when it is possible for the selected object. Otherwise it will be deactivated in the context menu.

A multi-select of objects is also supported.

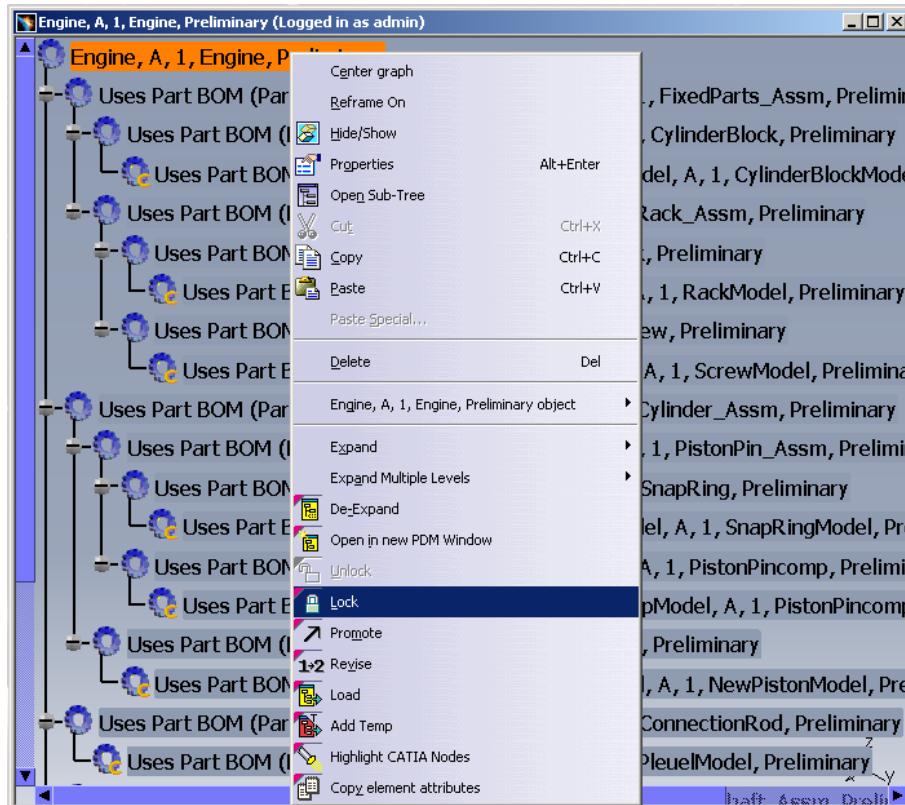

Picture 24: Action “Lock”

The confirmation message for the Lock opens (see *Picture 25: Confirm the Lock of the part*). If it is the correct object that you want to lock then just press the “Yes” button.

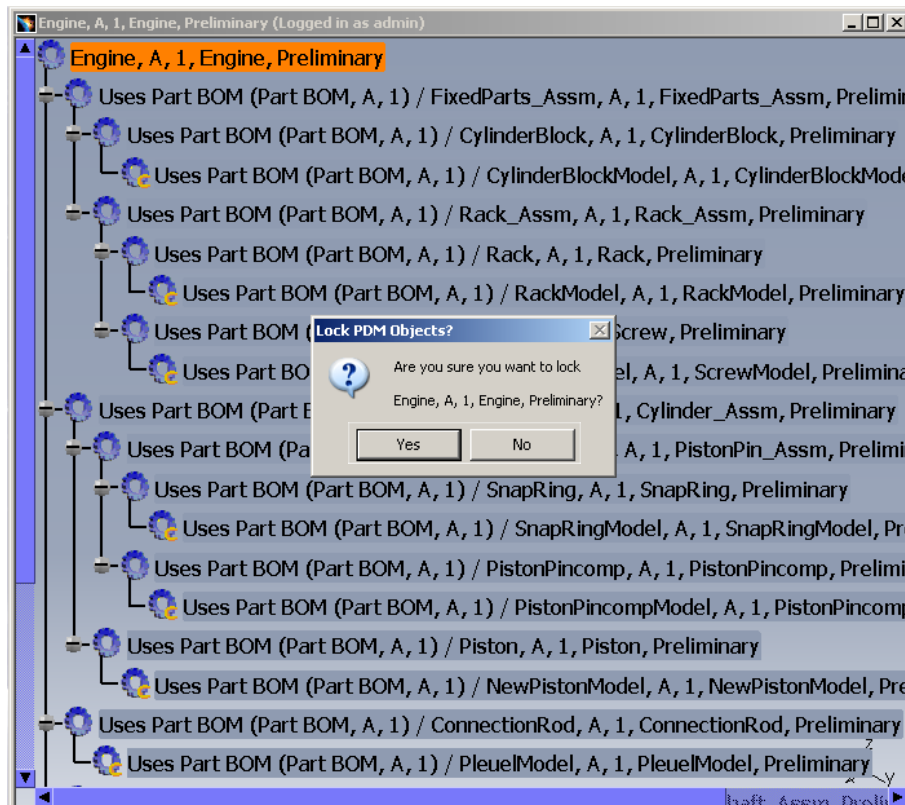

Picture 25: Confirm the Lock of the part

The selected object and the attached documents will be locked by the user (see *Picture 26: Object is locked*).

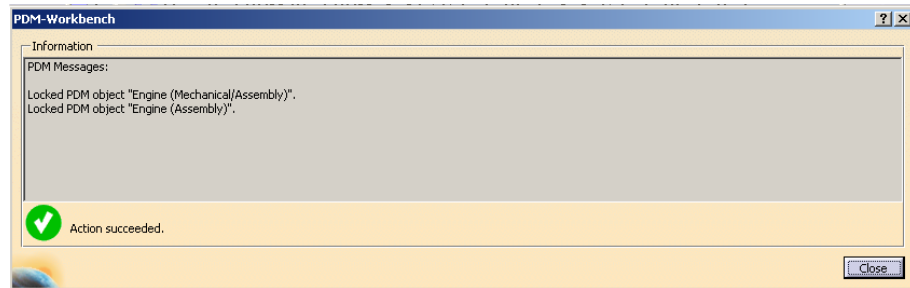

Picture 26: Object is locked

The background color of the locked object changed to green in the PDM-Workbench window (see *Picture 27: Locked object*).

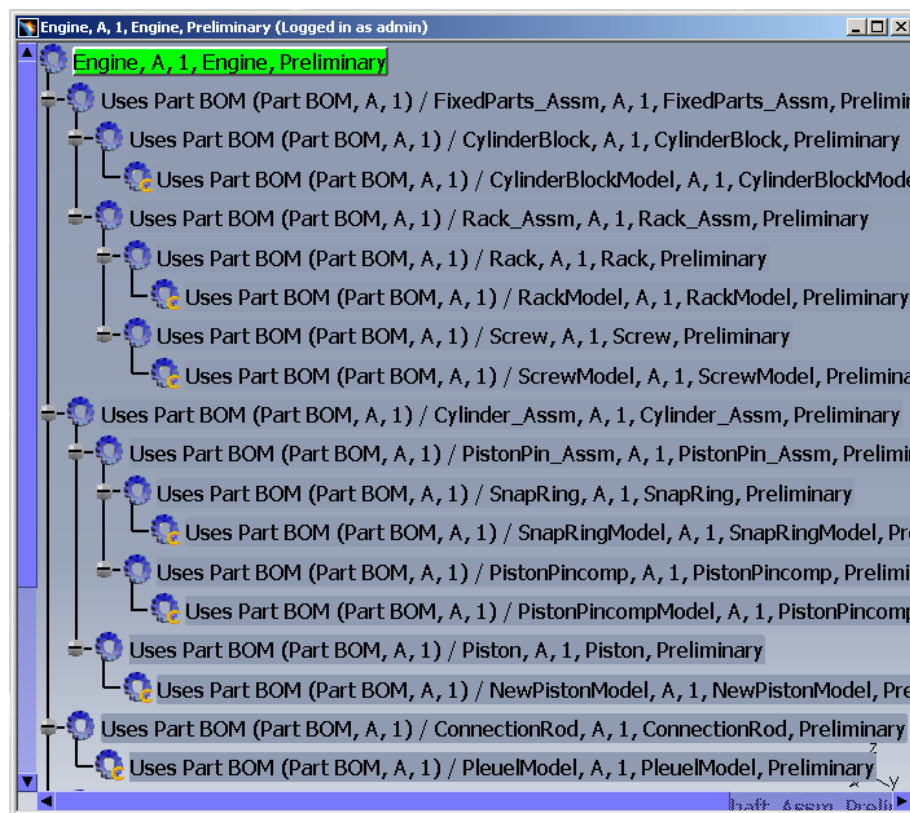

Picture 27: Locked object

The green background color of the locked object indicates that the object in the PDM system can be changed by the user.

Lock of the object in the Query dialog

It is also possible to lock the object from the query result list of the "Query" dialog. In the example in *Picture 28: Action "Lock" in the query result list* you select the object and click on "Lock" in the context menu. This action is only active in the context menu when it is possible for the selected object. Otherwise it will be deactivated in the context menu.

A multi-select of objects is also supported.

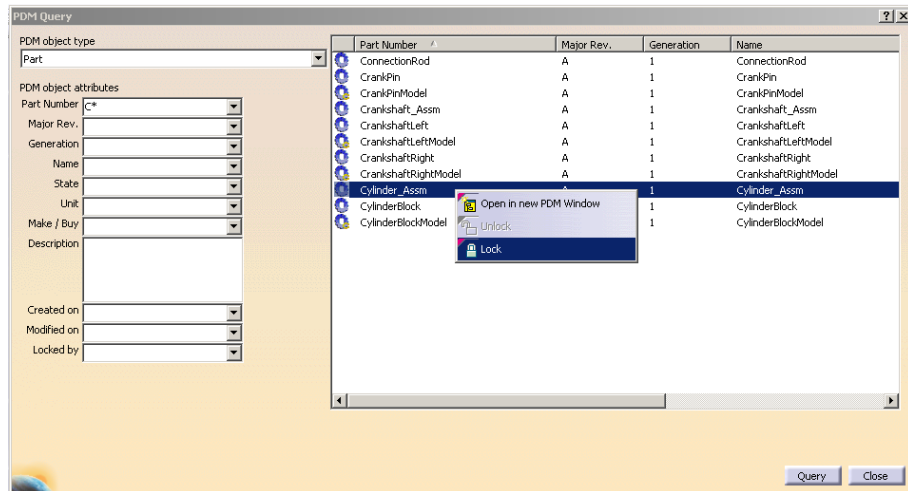

Picture 28: Action “Lock” in the query result list

Lock of the Document in the CATIA V5 window

You have to lock the PDM objects prior to changing and updating them.

You select the object in the CATIA V5 window and click the right mouse button. In the context menu you select the context action “PDM-Workbench→Lock” (see *Picture 29: Action “Lock” in the CATIA V5 window*).

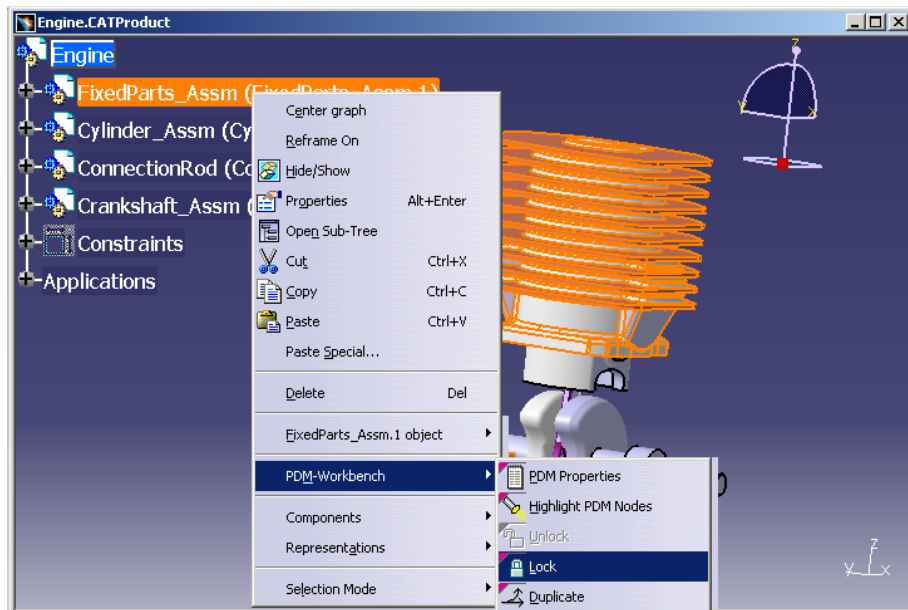

Picture 29: Action “Lock” in the CATIA V5 window

For further details of the lock dialogs please refer to the chapter *Lock of the Part in the PDM-Workbench window*.

The lock of a CATPart and CATDrawing as top level object of the CATIA V5 window cannot be done with the context menu. You have to use the “Lock” button of the “PDM-Workbench context commands” toolbar. The icons in this toolbar are only repainted (e.g. switch from “Lock” to “Unlock”) when you newly activate the CATIA V5 window.

A multi-select of objects is also supported.

Unlock

Unlock of the Part in the PDM-Workbench window

When an object is locked by you then you have to unlock it in the PDM system to make it available for all other users.

You select the object in the PDM-Workbench window and click the right mouse button. In the context menu you select the “Unlock” context action (see *Picture 30: Action “Unlock”*). This action is only active in the context menu when it is possible for the selected object. Otherwise it will be deactivated in the context menu.

A multi-select of objects is also supported.

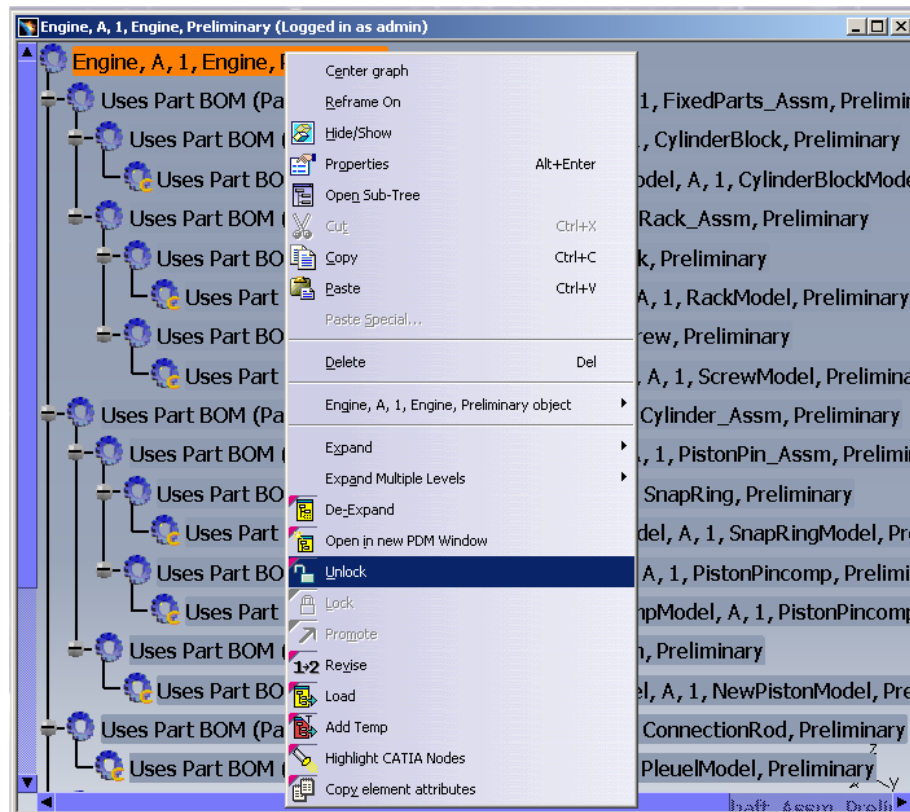

Picture 30: Action “Unlock”

The confirmation message for the “Unlock” opens (see *Picture 31: Confirm the Unlock of the part*). If it is the correct object that you want to unlock then just select the “Yes” button.

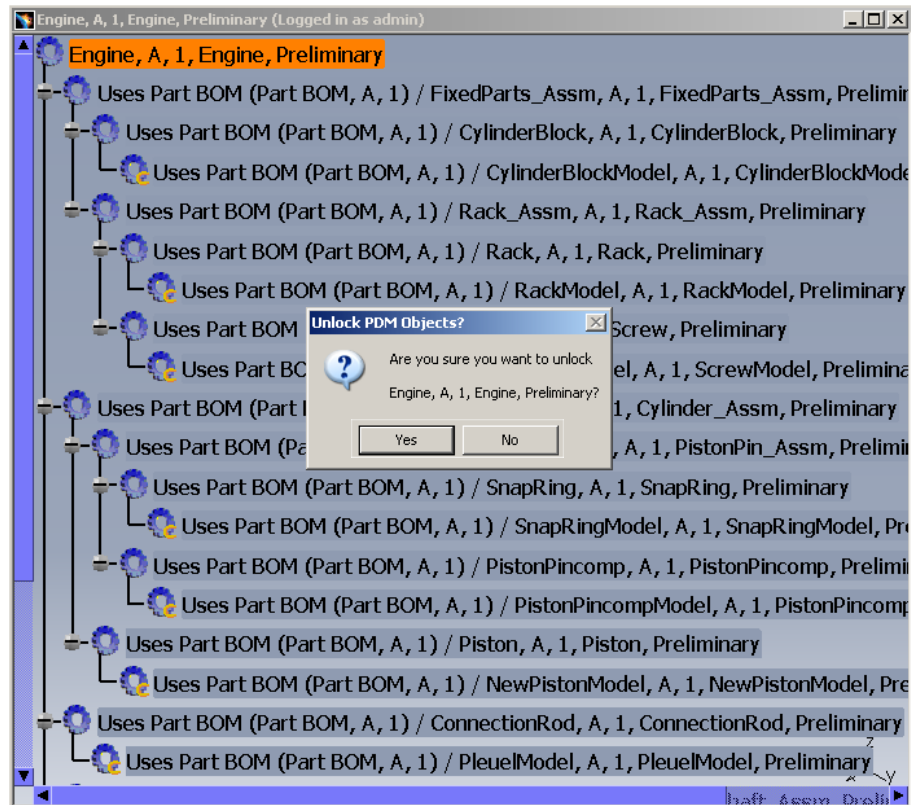

Picture 31: Confirm the Unlock of the part

The selected object and the attached documents will be unlocked by the user (see *Picture 32: Object is unlocked*).

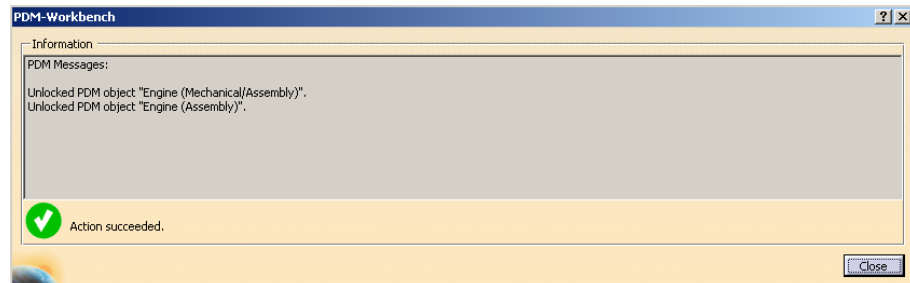

Picture 32: Object is unlocked

The background color of the unlocked object changed to blank in the PDM-Workbench window (see *Picture 33: Unlocked object*).

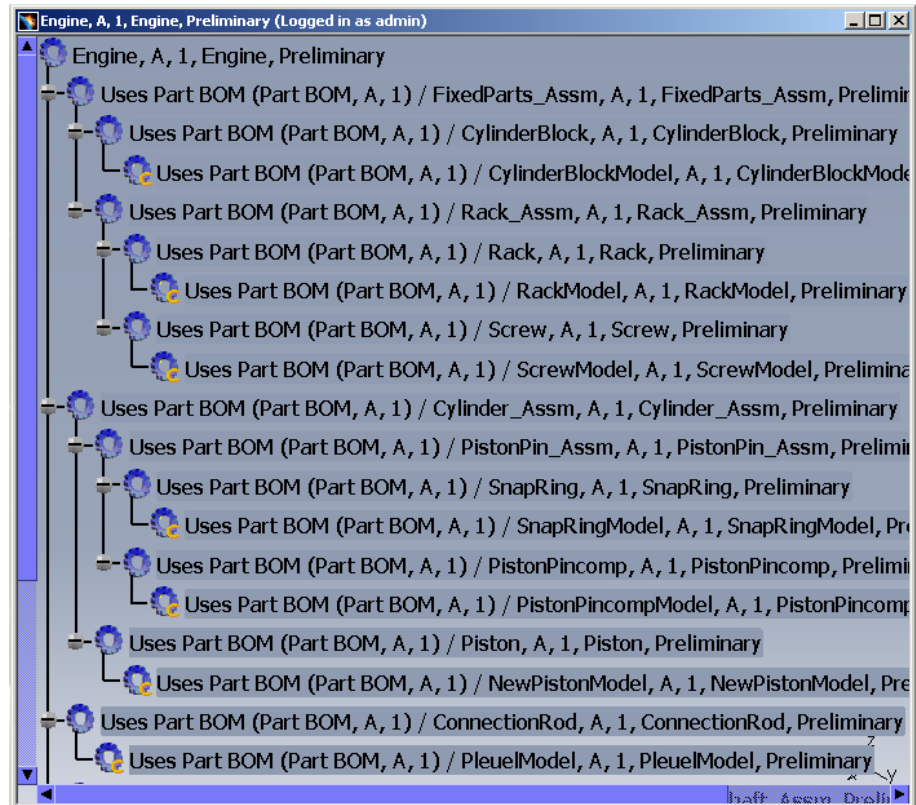

Picture 33: Unlocked object

The blank background color of the unlocked object indicates that the object in the PDM system cannot be changed by the user.

Unlock of the object in the Query dialog

It is also possible to unlock the object from the query result list of the "Query" dialog. In the example in *Picture 34: Action "Unlock" in the query result list* you select the object and click on "Unlock" in the context menu. This action is only active in the context menu when it is possible for the selected object. Otherwise it will be deactivated in the context menu.

A multi-select of objects is also supported.

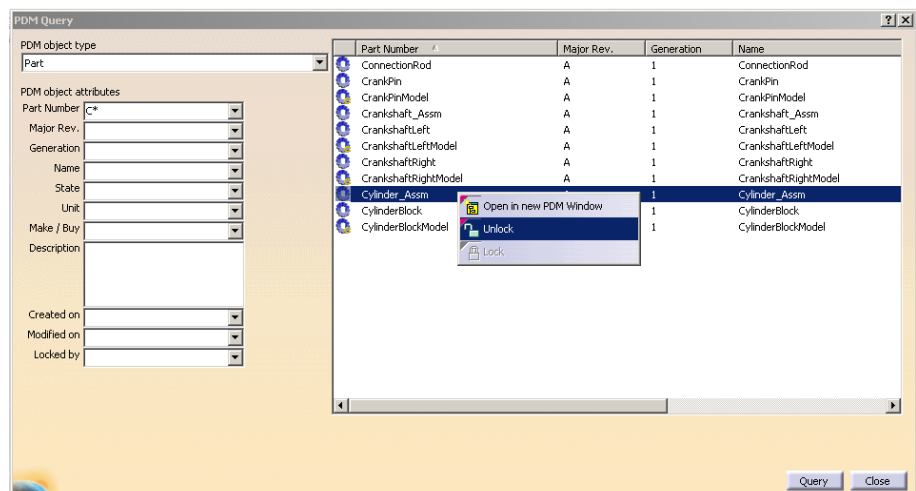

Picture 34: Action "Unlock" in the query result list

Unlock of the Document in the CATIA V5 window

When an object is locked by you then you can unlock it in the PDM system to make it available for all other users.

You select the object in the CATIA V5 window and click the right mouse button. In the context menu you select the context action “PDM-Workbench→Unlock” (see *Picture 35: Action “Unlock” in the CATIA V5 window*).

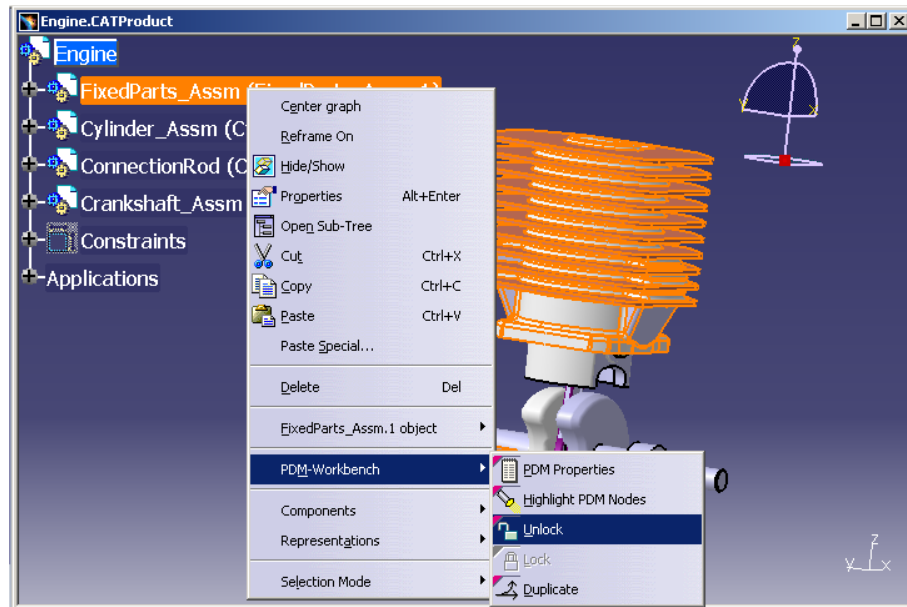

Picture 35: Action “Unlock” in the CATIA V5 window

For further details of the “Unlock” dialogs please refer to the chapter *Unlock of the Part in the PDM-Workbench window*.

The unlock of a CATPart and CATDrawing as top level object of the CATIA V5 window cannot be done with the context menu. You have to use the “Unlock” button of the “PDM-Workbench context commands” toolbar. The icons in this toolbar are only repainted (e.g. switch from “Lock” to “Unlock”) when you newly activate the CATIA V5 window.

A multi-select of objects is also supported.

Promote

The PDM objects can be promoted.

You select the object in the PDM-Workbench window and click the right mouse button. In the context menu you select the “Promote” context action (see *Picture 36: Action “Promote”*).

The part and the document have to be unlocked in order to be promoted.

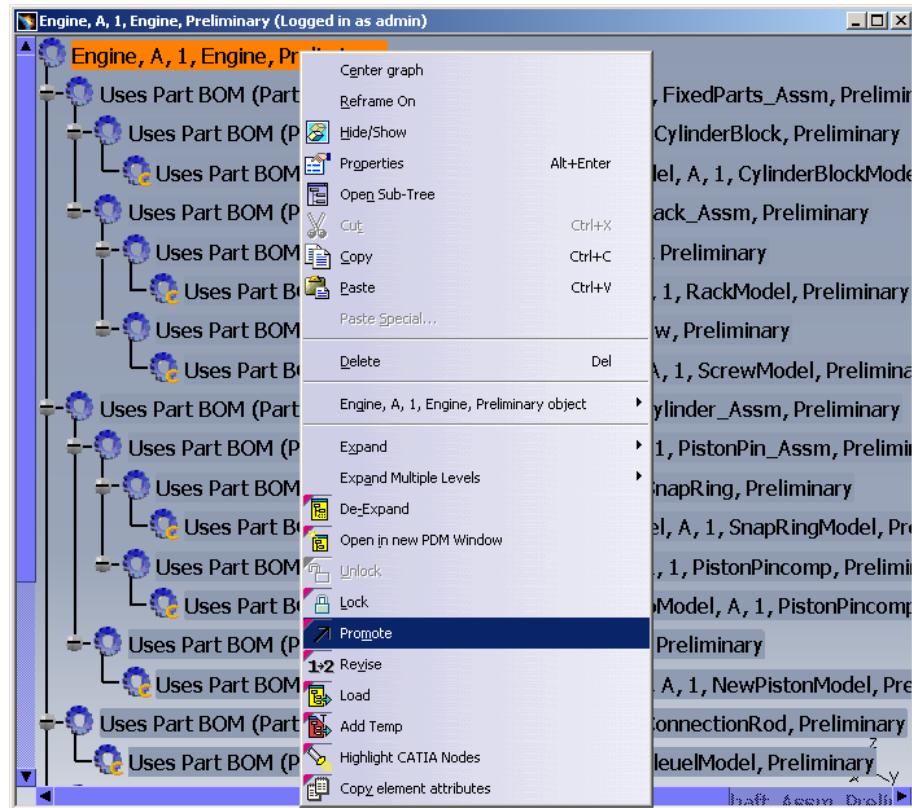

Picture 36: Action “Promote”

You will be asked if you really want to promote the objects. Please confirm with "Yes" (see *Picture 37: Confirm the “Promote” action*).

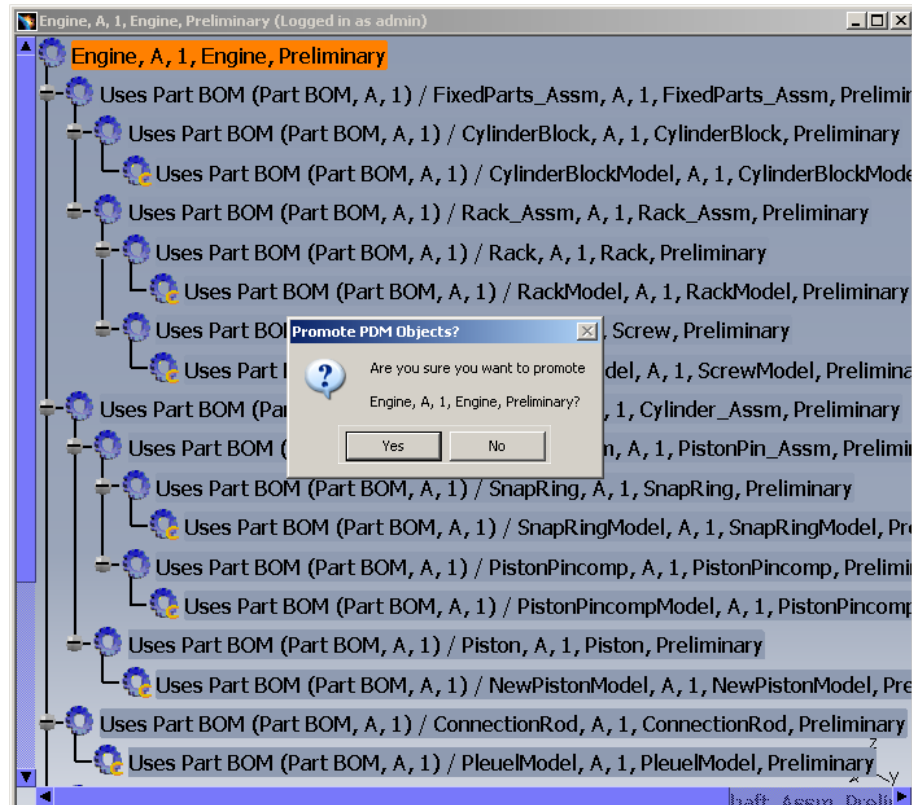

Picture 37: Confirm the “Promote” action

The selected object and the attached documents will be promoted. In this example from the life cycle state "Preliminary" to the state "In Review" (see *Picture 38: Object is promoted*).

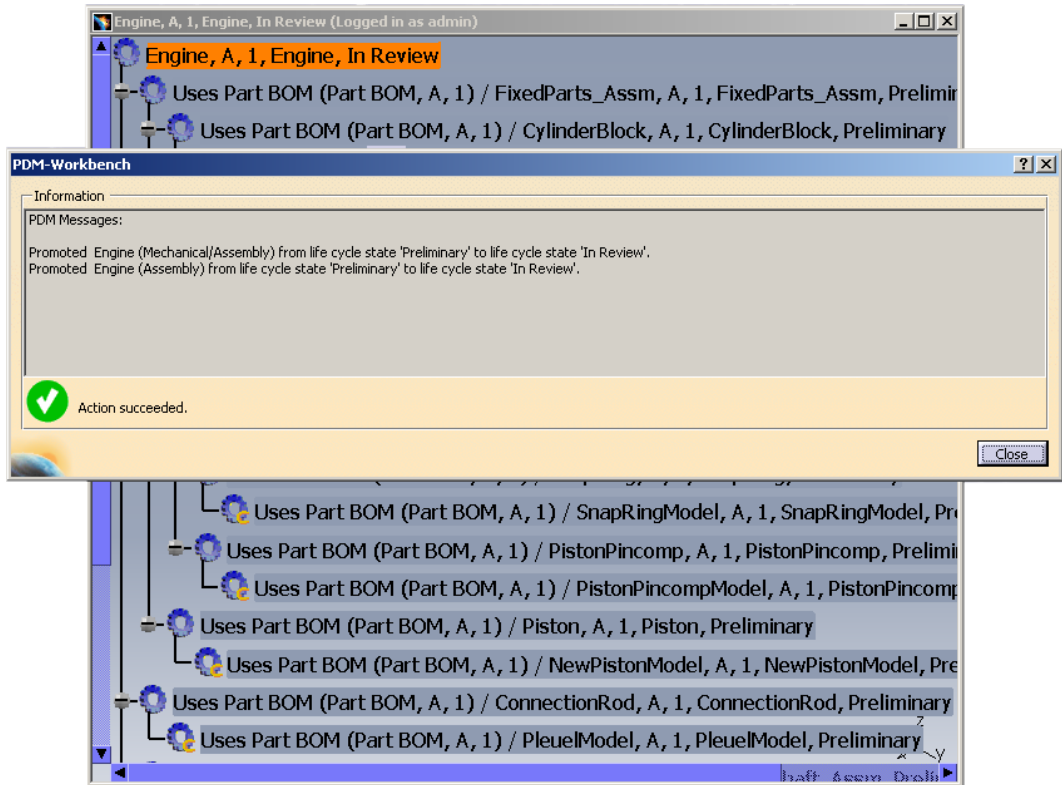

Picture 38: Object is promoted

Revise

The PDM objects can be revised.

You select the object in the PDM-Workbench window and click the right mouse button. In the context menu you select the "Revise" context action (see *Picture 39: Action "Revise"*).

The part and the document have to be released in order to be revised.

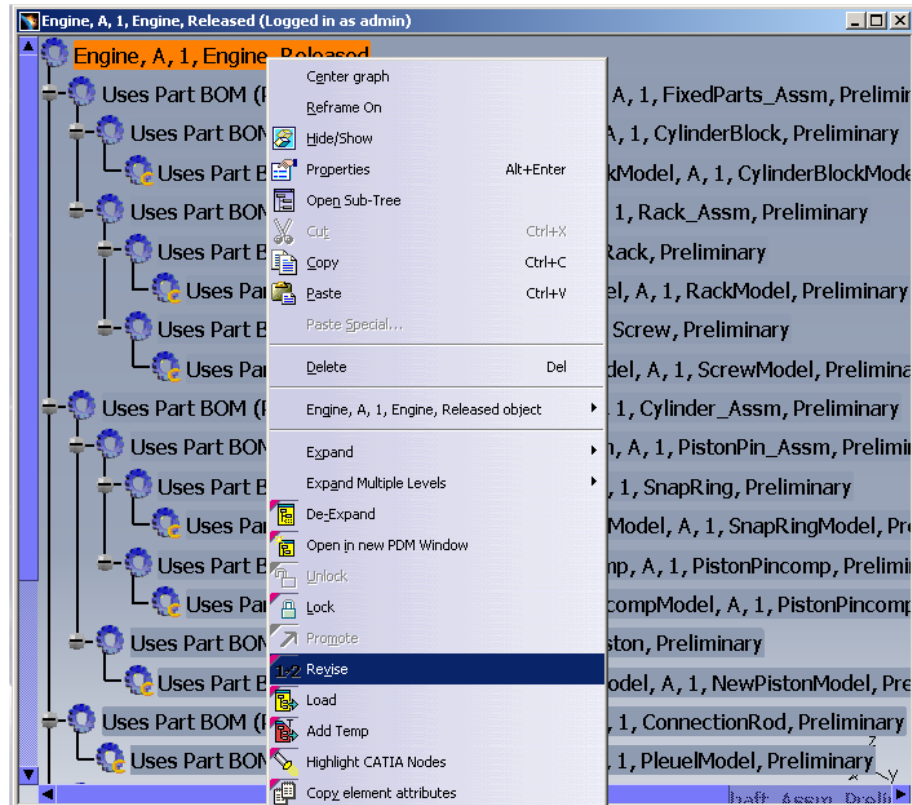

Picture 39: Action “Revise”

You will be asked if you really want to revise the object. Please confirm with "Yes" (see *Picture 40: Confirm the “Revise” action*).

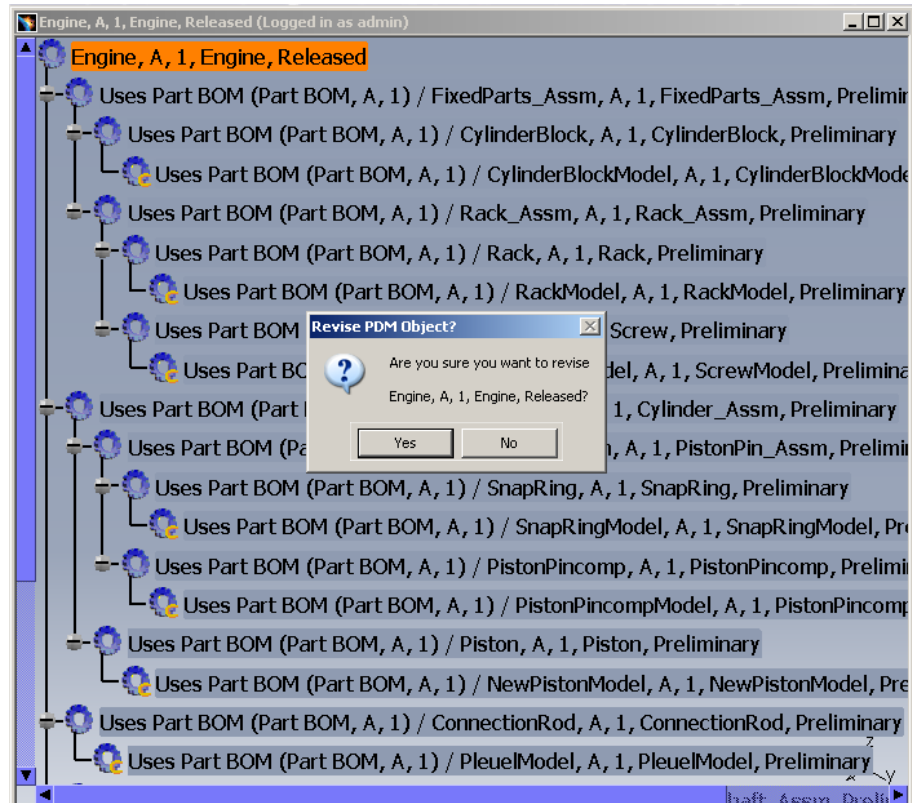

Picture 40: Confirm the “Revise” action

The selected object will be revised (see *Picture 41: Object is revised*).

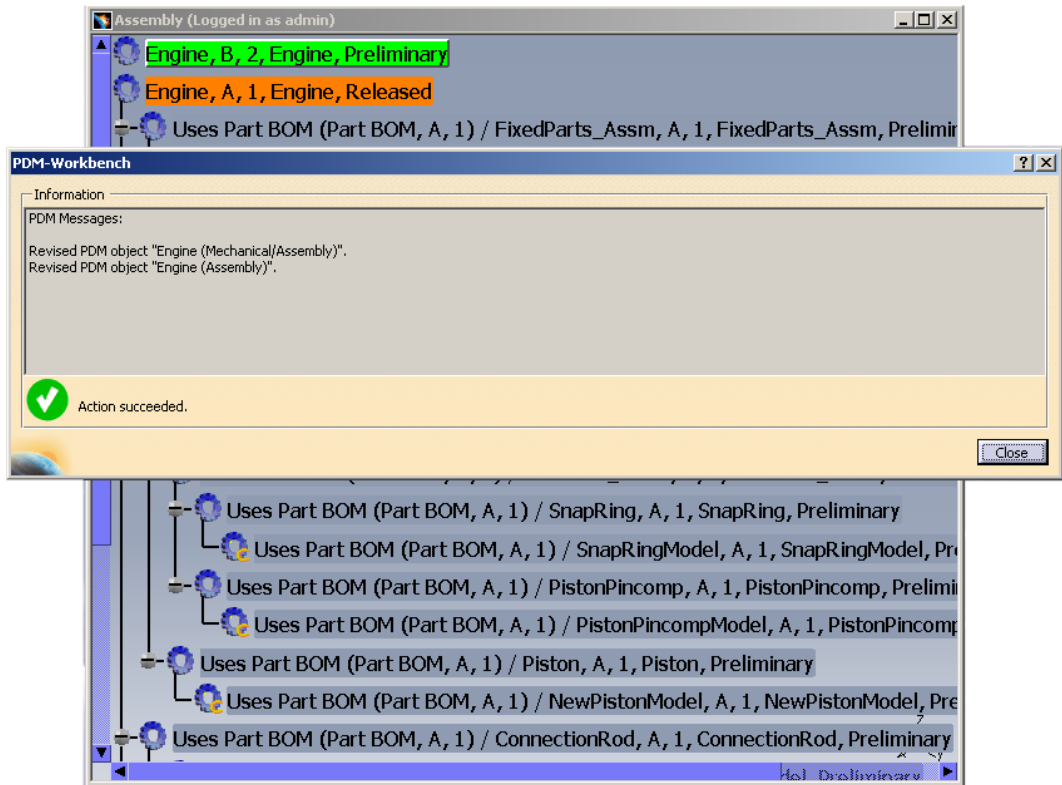

Picture 41: Object is revised

The new object was added in the window on the top.

Update structure relations

This functionality is only available for the document data model.

You have the possibility to update an object with a new revision of an already used object.

In this example the document "FixedParts_Assm" has been revised from "A" to "B". The revision "A" was already used by the document "Engine".

You have to select the CATIA Product "Engine" and choose "Update structure relations" (see *Picture 42: Action "Update structure relations"*).

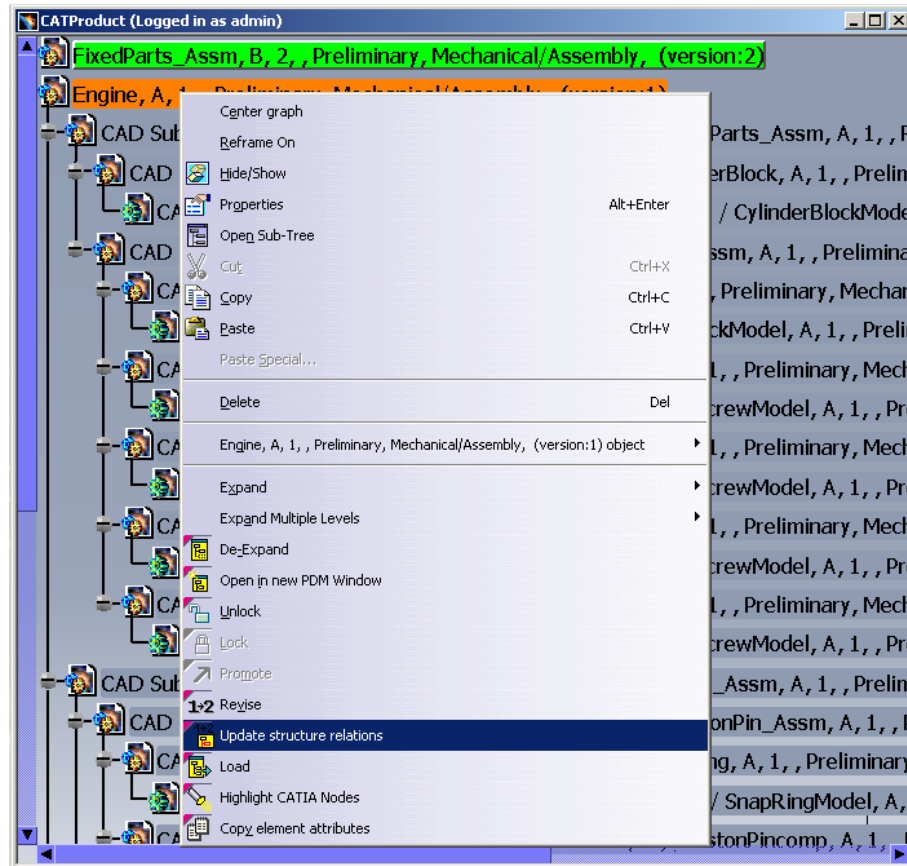

Picture 42: Action “Update structure relations”

Now the new revisions of the used objects are related to this object and the relations to the old revisions are deleted.

You can see that the revision "B" of the "FixedParts_Assm" is used by the "Engine" now (see *Picture 43: Updated structure relations*).

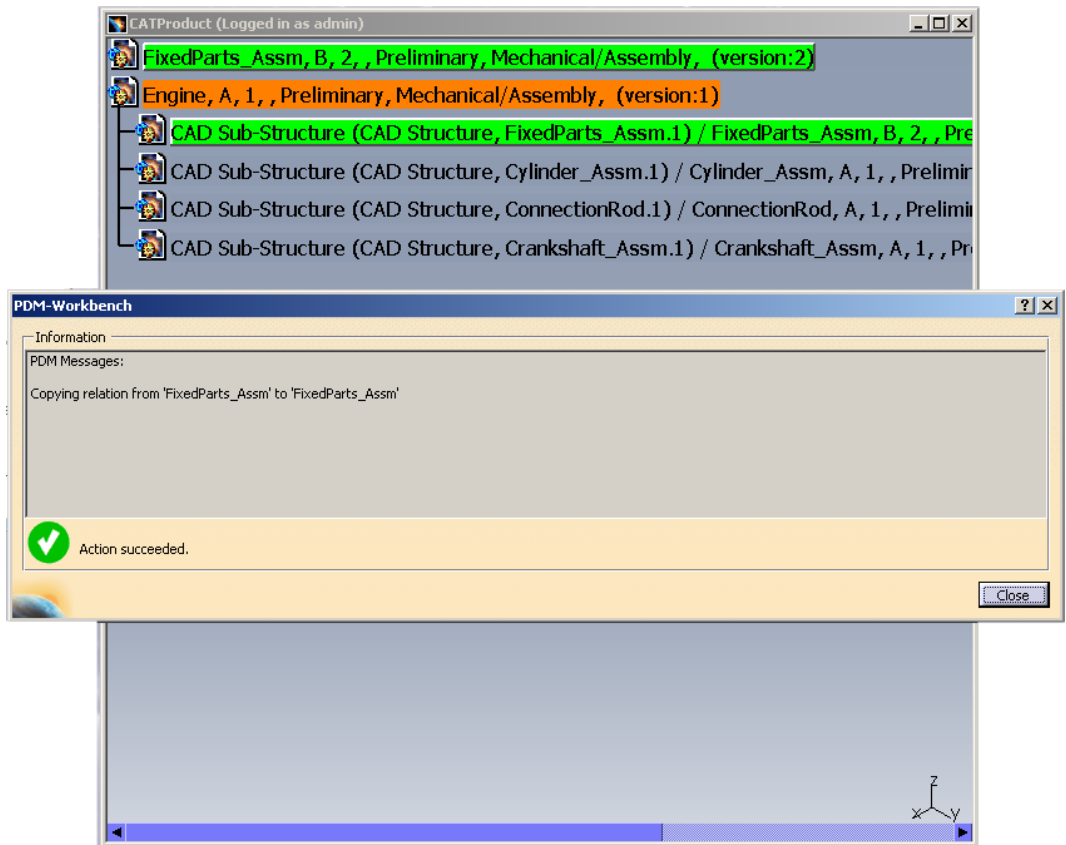

Picture 43: Updated structure relations

Delete

Existing PDM objects can be deleted from the PDM-Workbench. Delete is a set based operation, which means multiple objects can be deleted in one action.

Select objects in the PDM-Workbench window and from the contextual menu choose "Delete" (see *Picture 44: Action "Delete"*).

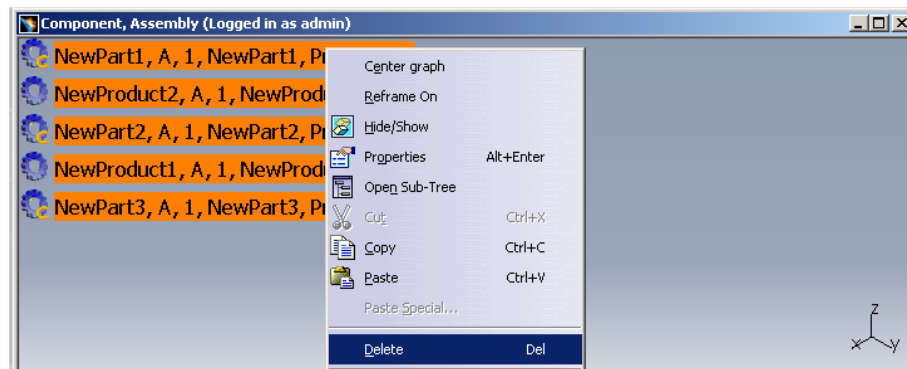

Picture 44: Action "Delete"

A confirmation message box is displayed listing the objects which will be deleted. When you confirm this dialog with "Yes" the objects will be deleted.

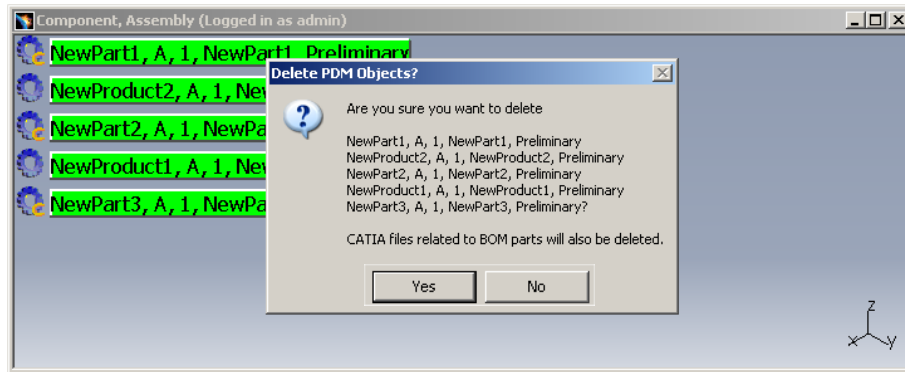

Picture 45: Confirm Delete objects

The operation result dialog is displayed containing error or success messages.

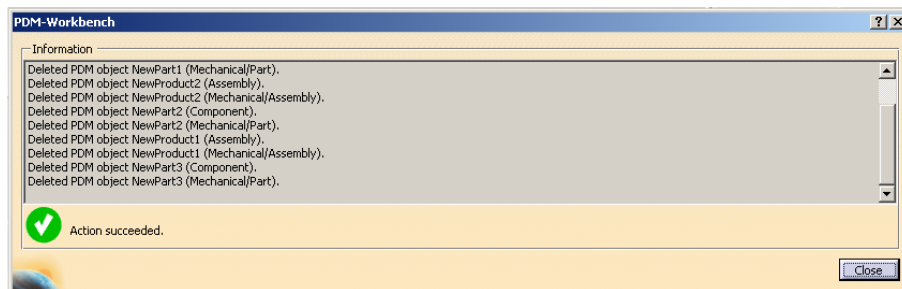

Picture 46: Delete result window

When you delete a part object the attached documents will be deleted, too.

Delete newest version

You can delete the newest version of the file when there exist more than one version for the file and you see that you do not need this version anymore because you want to design the geometry a different way.

You have to select the last version of the document and click on the right mouse button. The context menu will be opened. There you select "Delete newest version" (see *Picture 47: Action "Delete newest version"*).

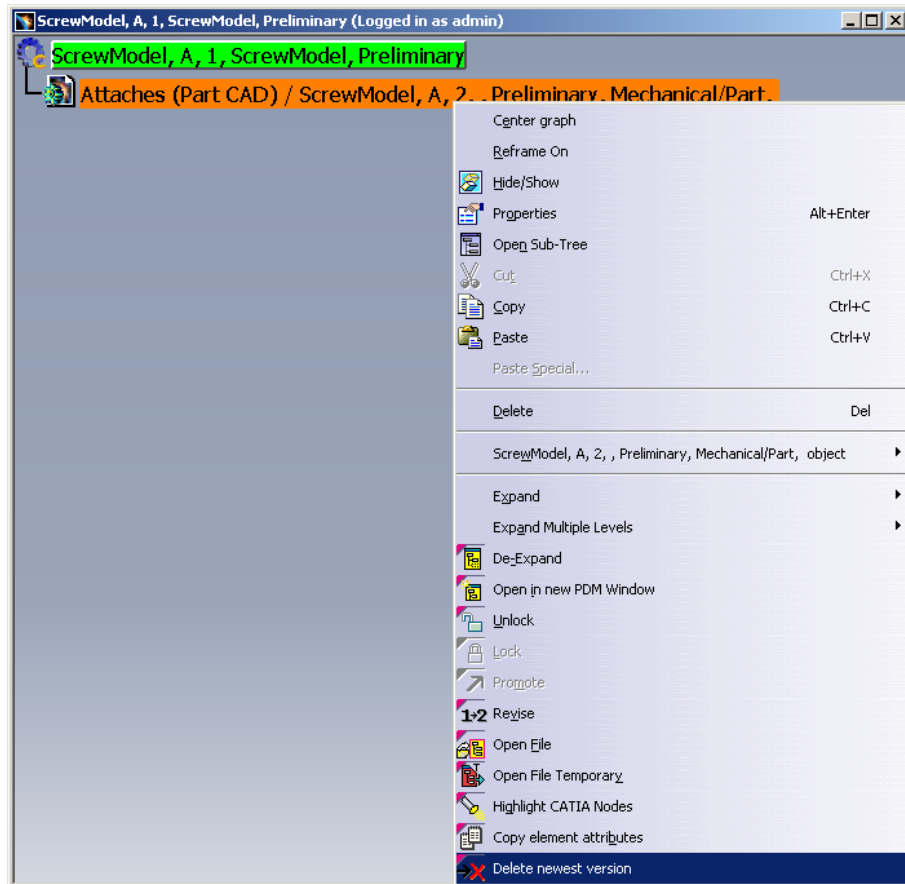

Picture 47: Action "Delete newest version"

Then you are asked to confirm the delete of the newest version. You have to click the "Yes" button (see *Picture 48: Confirm Delete newest version*).

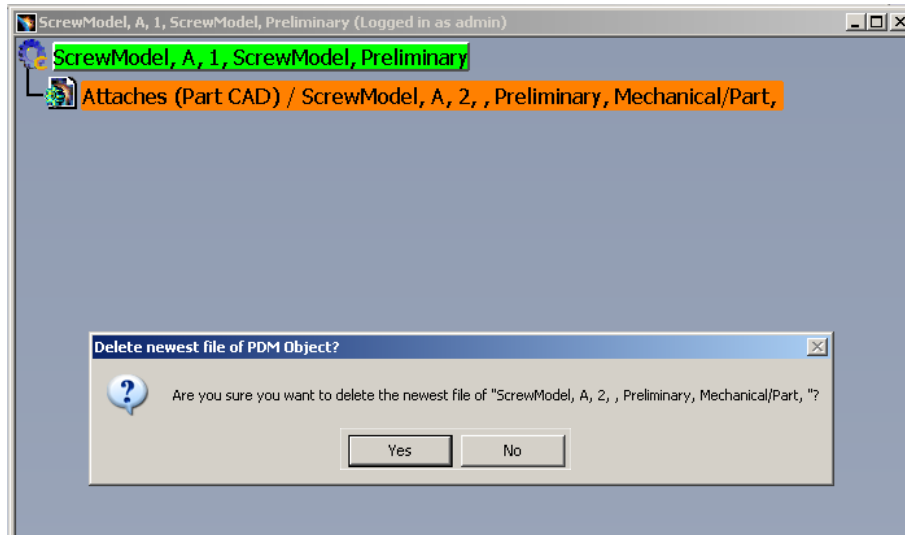

Picture 48: Confirm Delete newest version

The newest version will be deleted. The document will be removed from the window (see *Picture 49: Delete newest version result window*).

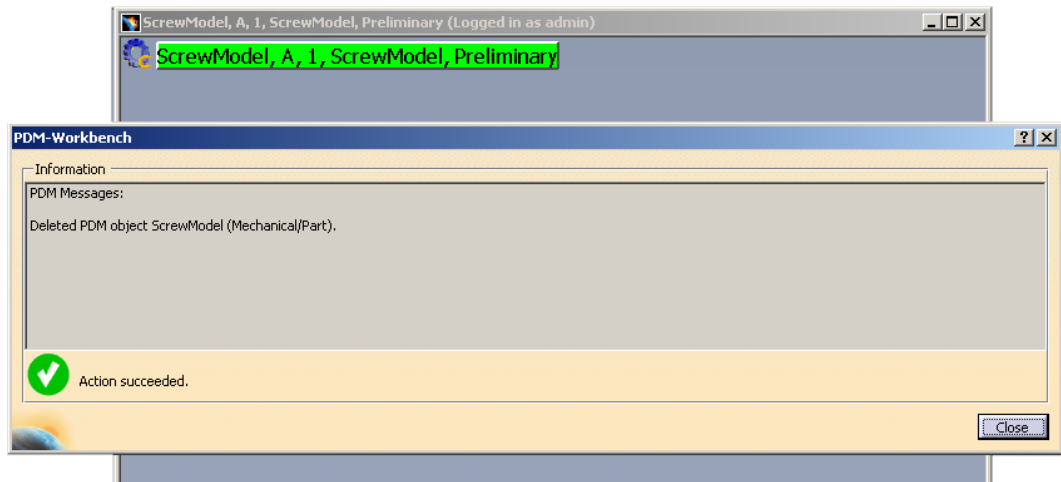

Picture 49: Delete newest version result window

You have to re-expand the document in order to see the document that is attached to the component (see *Picture 50: Re-Expand of the document*).

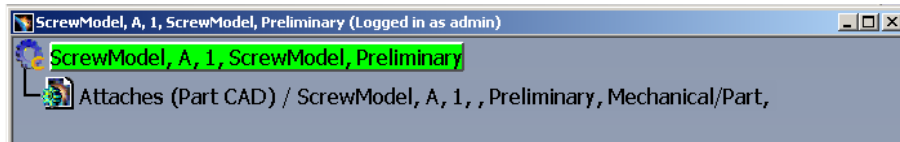

Picture 50: Re-Expand of the document

Open File

This functionality is only available for the document data model.

You can open a single CATIA V5 Drawing file existing in the PDM data base with the PDM-Workbench in the native CATIA V5 window.

You can also open a single CATIA V5 Part or CATIA V5 Product file existing in the PDM data base in the native CATIA V5 window.

To open the file in CATIA V5 you select the PDM file object in the PDM-Workbench window and click the right mouse button to open the context menu. There you select the context action "Open File" (see *Picture 51: Action "Open File"*).

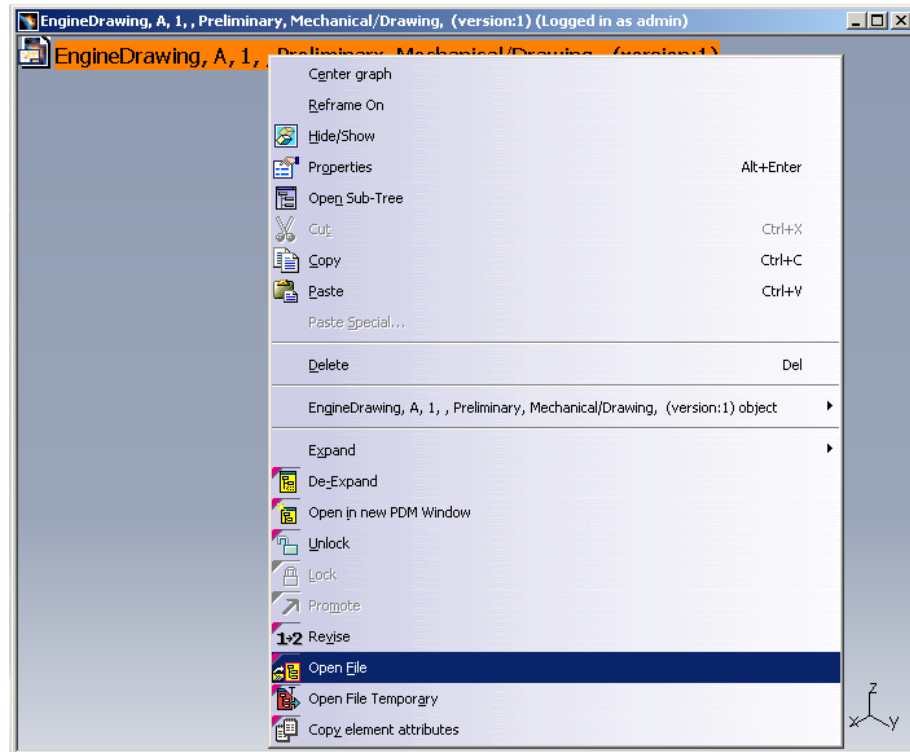

Picture 51: Action “Open File”

The PDM-Workbench downloads the required CAD file to the client’s special PDM-Workbench exchange map. You can watch the download progress on the “Open File” progress bar (see *Picture 52: Open File - progress bar*).

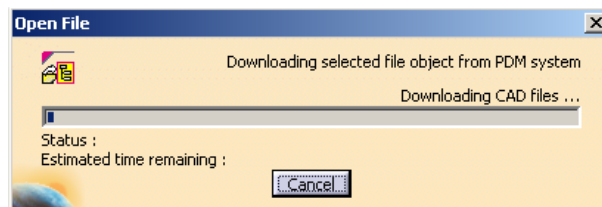

Picture 52: Open File - progress bar

The geometry opens in its corresponding CATIA V5 native window (see *Picture 53: Split window after Open File – PDM-Workbench node and CATIA drawing*).

In the above window (PDM-Workbench window) you see the selected PDM file object. The window on the bottom shows the loaded CATDrawing.

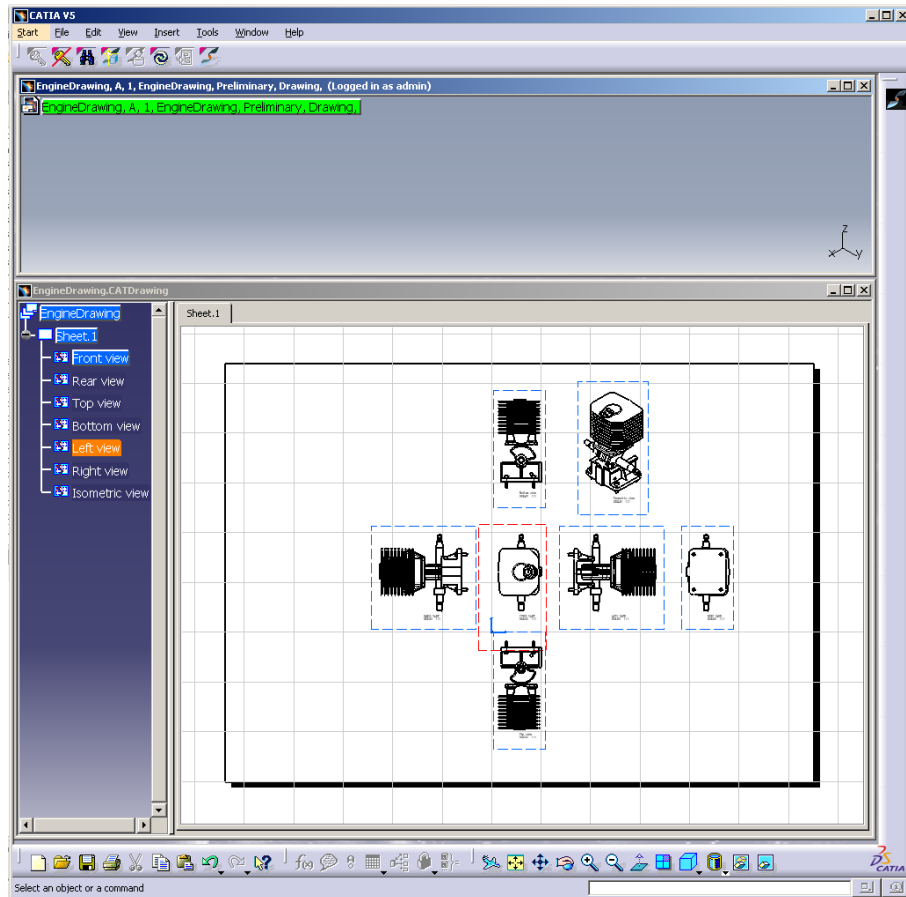

Picture 53: Split window after Open File – PDM-Workbench node and CATIA drawing

Open File Temporary

This functionality is only available for the document data model.

The action "Open File Temporary" allows the user to visualize a temporary file of a different version together with the working version.

In the first step you load the current version of the file. In this example you open the version "2" of the "ScrewModel".

You select the object and click on the right mouse button. In the context menu you select the action "Open File" (see *Picture 54: Action "Open File"*).

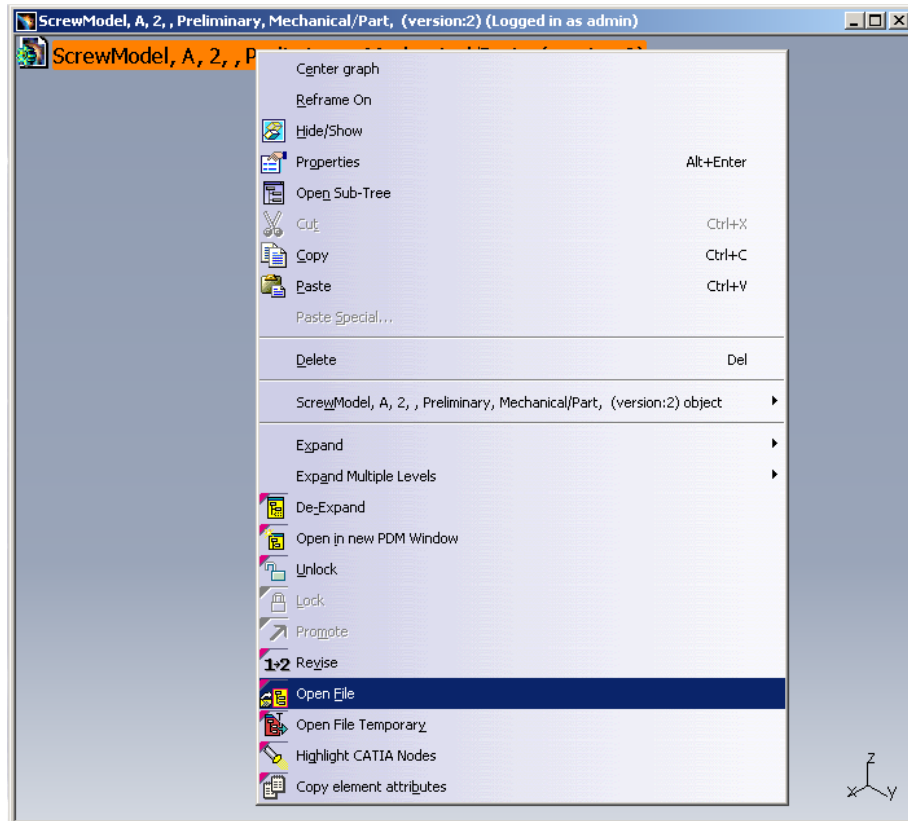

Picture 54: Action "Open File"

The current version of the file is loaded in CATIA V5, now (see *Picture 55: Current file*).

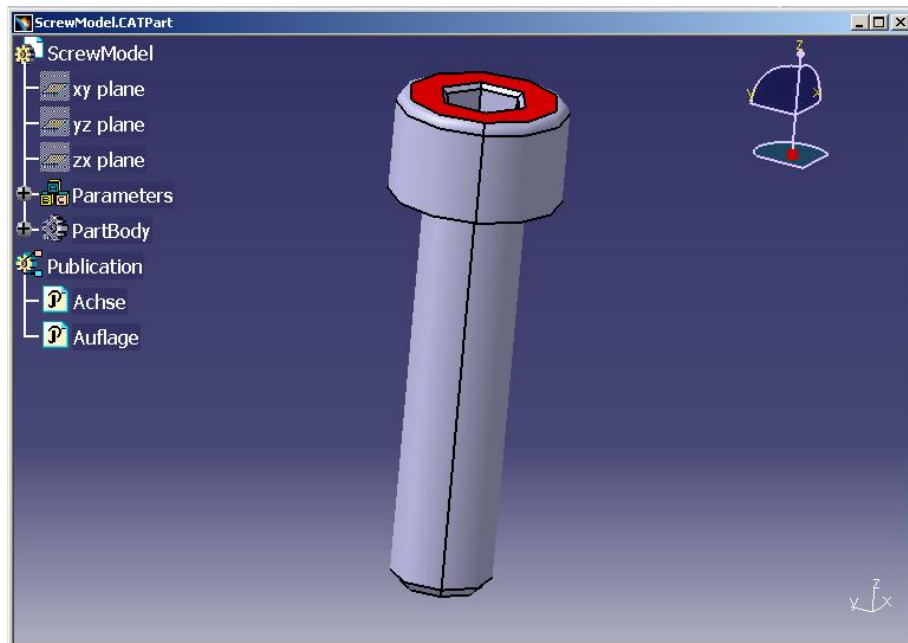

Picture 55: Current file

Then you query for a different version (in this case version "1") and open the file temporary.

You select the object and click on the right mouse button. In the context menu you select the action "Open File Temporary" (see *Picture 56: Action "Open File Temporary"*).

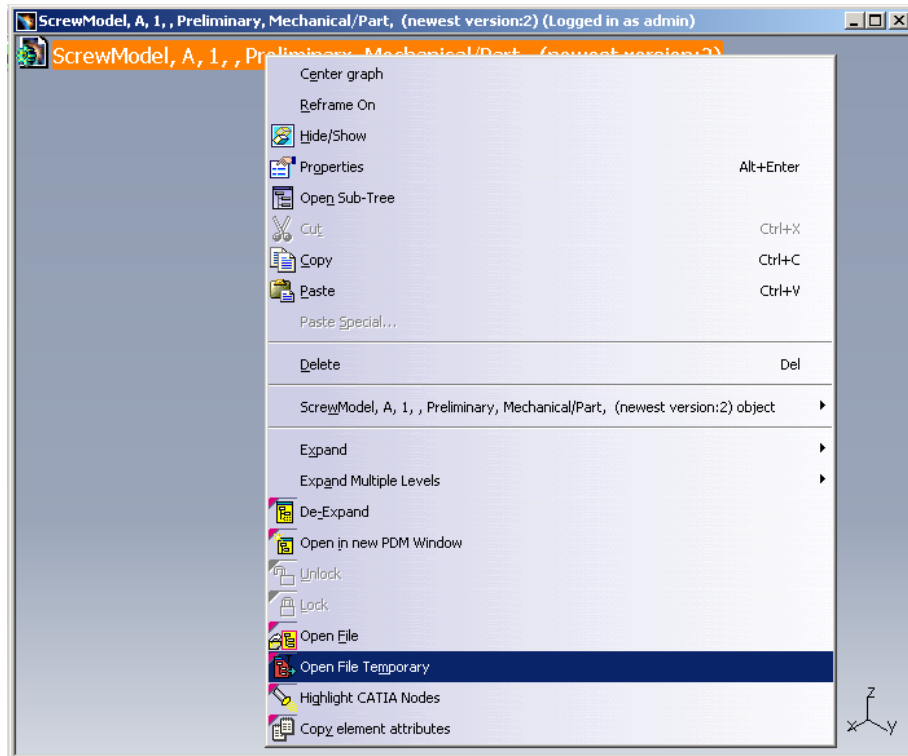

Picture 56: Action “Open File Temporary”

The version "1" of the file is opened temporary in CATIA V5 (see *Picture 57: Temporary opened file*).

The Part Number and the File Name of the temporarily opened geometry are prefixed with “TMP#_”, where “#” is a counter in CATIA V5, beginning with 1. Every action "Open File Temporary" will increase the counter. This prefix is customisable by the customer. For details please refer to the *PDM-Workbench Installation & Administration Manual*.

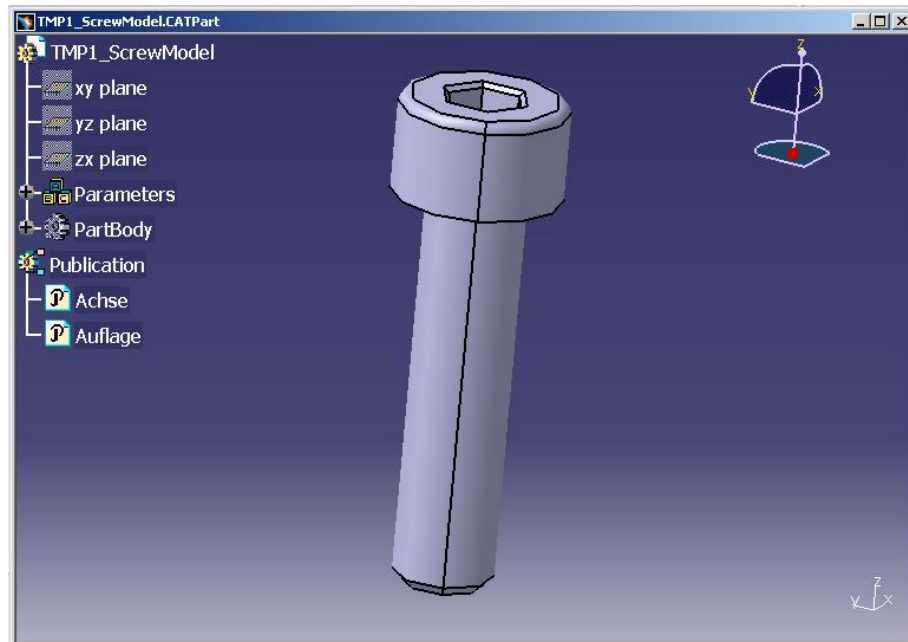

Picture 57: Temporary opened file

Now you can compare the both versions of the file.

Load

It is possible to load geometry corresponding to an expanded PDM product structure into a native CATIA V5 window in order to work on it, e.g. perform geometric transformations, geometry changes and so on.

To load the geometry in CATIA V5 you select the root PDM object wherefrom downward you want to get the geometry and click the right mouse button to open the context menu and you select the context action “Load” (see *Picture 58: Action “Load”*).

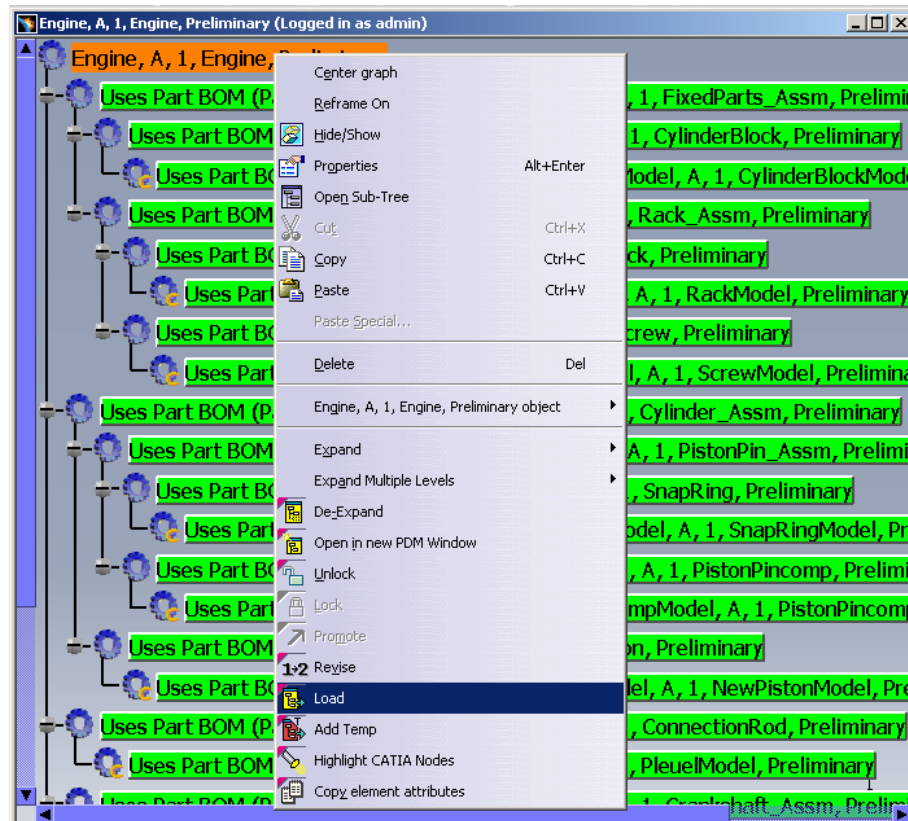

Picture 58: Action “Load”

The PDM-Workbench downloads the corresponding CAD files (CATParts, CATProducts, and CATDrawings) to the client’s PDM-Workbench exchange map. The download progress is indicated by the “Load” progress bar (see *Picture 59: Load - progress bar*).

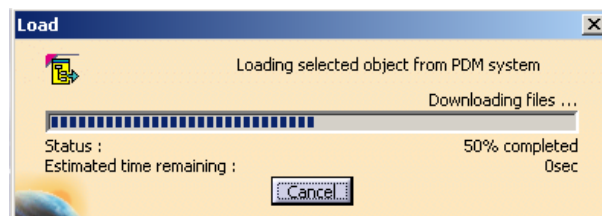

Picture 59: Load - progress bar

The geometry downloaded opens in a CATIA V5 native window (see *Picture 60: Split window after Load – PDM-Workbench and CATIA V5 nodes*).

In the left window (PDM-Workbench window) you see the expanded product structure wherefrom you opened the CATIA V5 native window presenting the geometry on the right. In the right window you see the loaded geometry.

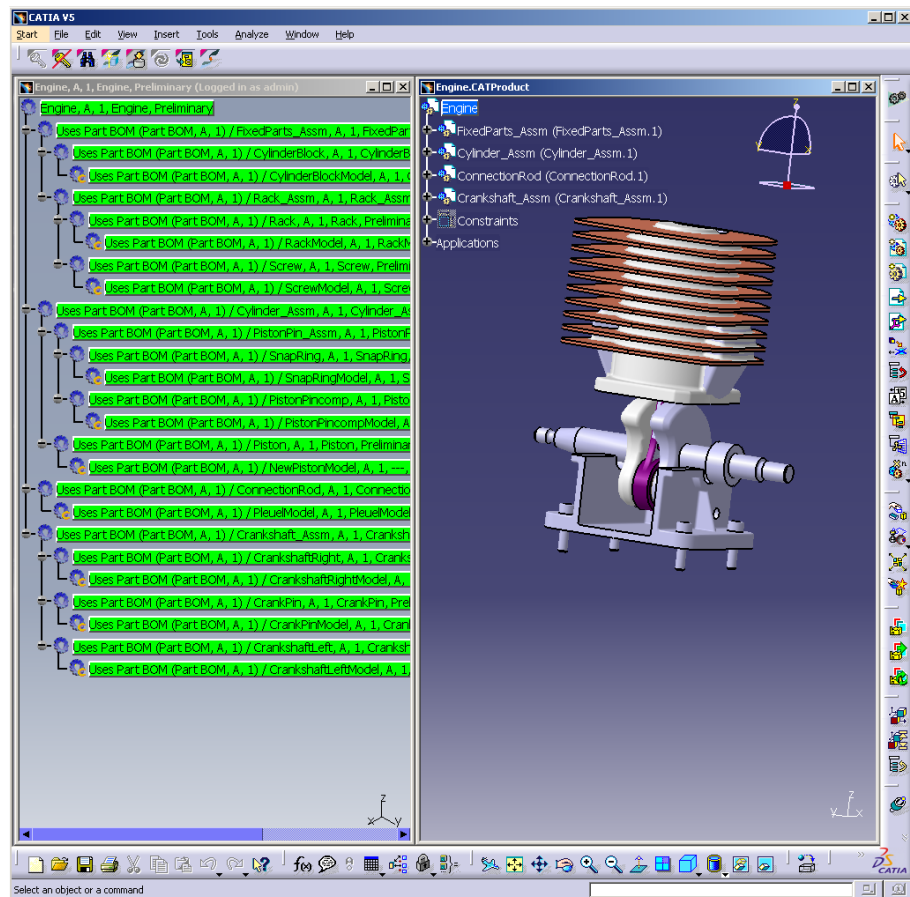

Picture 60: Split window after Load – PDM-Workbench and CATIA V5 nodes

Add Temp

The action "Add Temp" allows the user to visualize a temporary structure together with the working one.

In the first step you load the current version of the structure. In this example you open the revision "B" of the "Engine".

You select the object and click on the right mouse button. In the context menu you select the action "Load" (see *Picture 61: Action "Load"*).

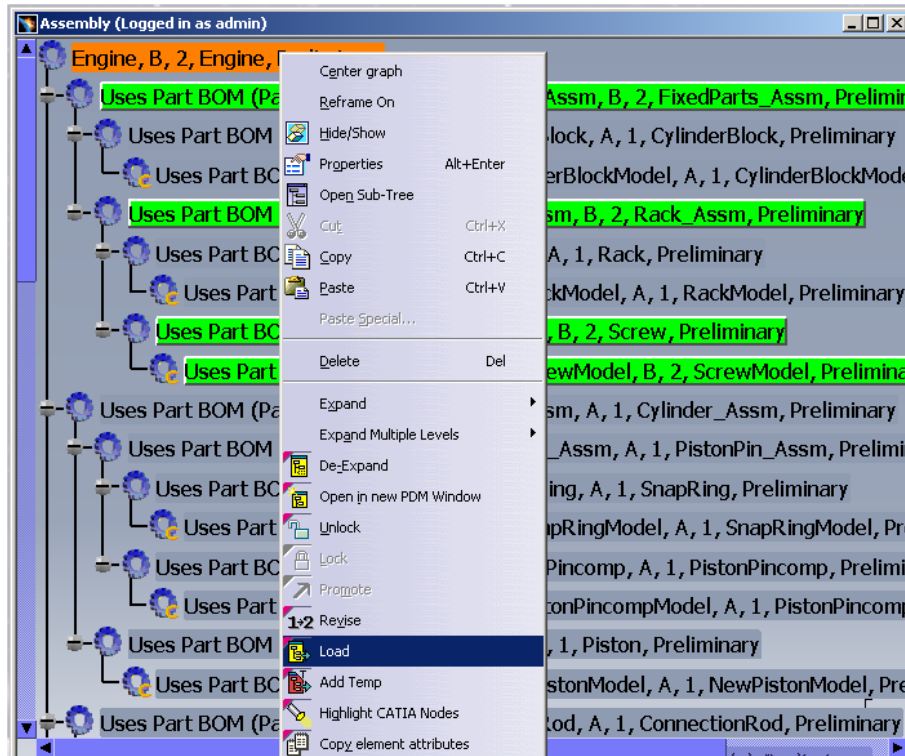

Picture 61: Action "Load"

The current version of the structure is loaded in CATIA V5, now (see *Picture 62: Loaded geometry for revision "B"*).

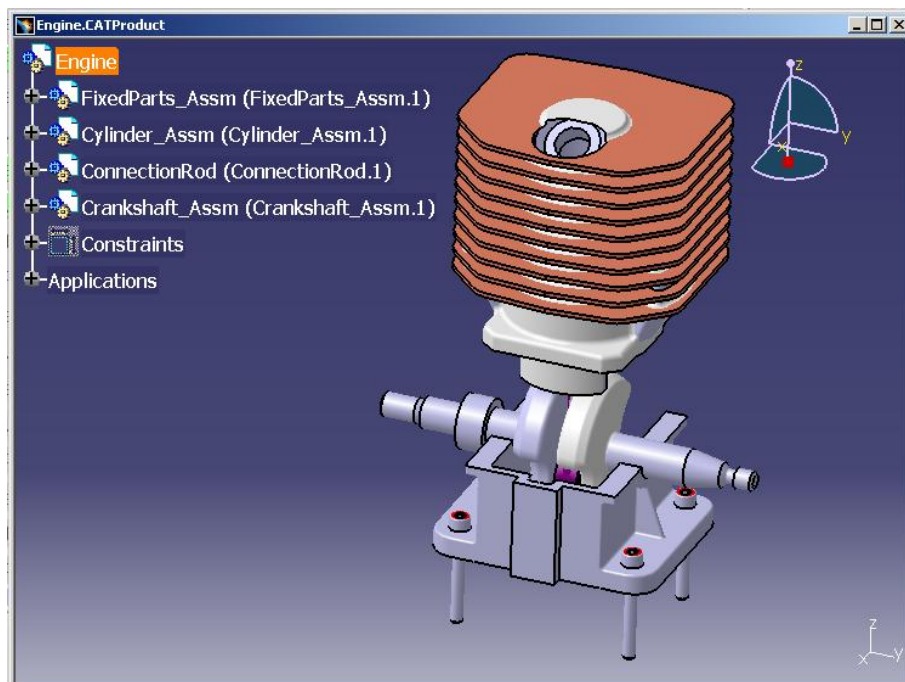

Picture 62: Loaded geometry for revision "B"

Then you query for a different version (in this case revision "A") and load the structure temporary.

You select the object and click on the right mouse button. In the context menu you select the action "Add Temp" (see *Picture 63: Action "Add Temp"*).

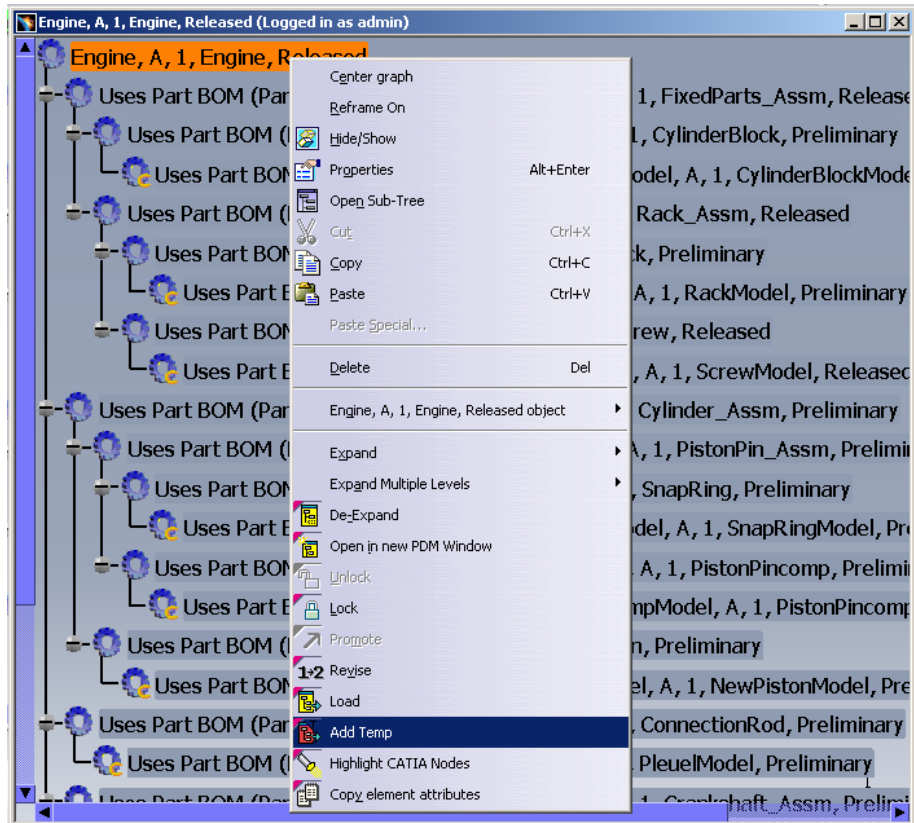

Picture 63: Action "Add Temp"

The CATProducts will not be loaded. Only the CATParts are loaded and positioned correctly (see *Picture 64: Loaded geometry for revision "A"*).

All Part Numbers and File Names in the temporarily added structure are prefixed with "TMP#_", where "#" is a counter in CATIA V5, beginning with 1. Every action "Add Temp" will increase the counter. This prefix is customisable by the customer. For details please refer to the *PDM-Workbench Installation & Administration Manual*.

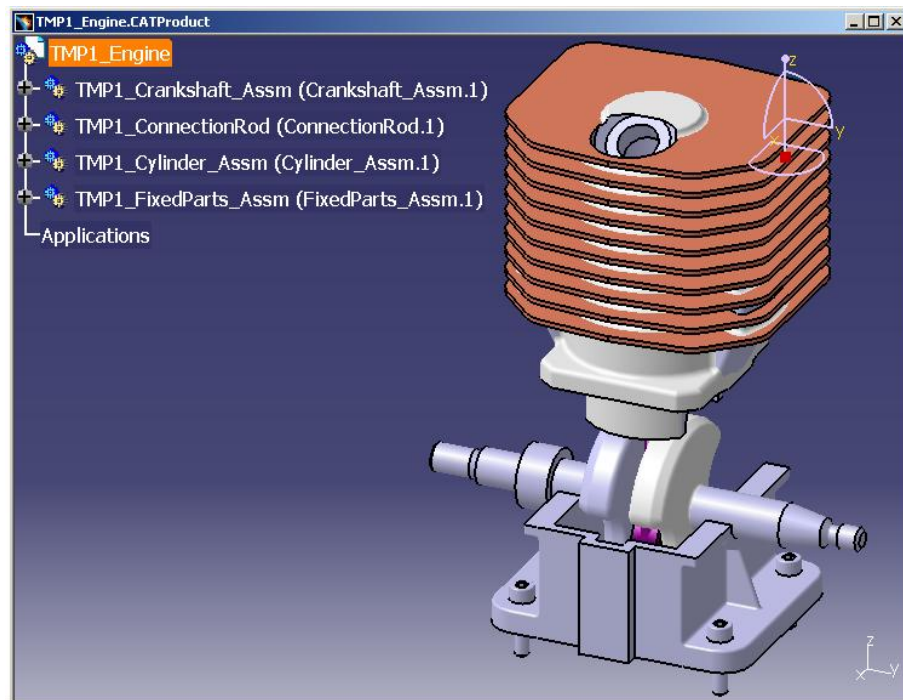

Picture 64: Loaded geometry for revision "A"

Now you can compare both geometry structures.

Duplicate

It is possible to duplicate existing CATProduct and CATPart objects.

You have to open the objects in CATIA V5 and click on the right mouse button in order to open the context menu. There you have to select the action "Duplicate" (see *Picture 65: Action "Duplicate"*).

For CATParts you have to use the "Duplicate" action in the "PDM-Workbench context commands" toolbar.

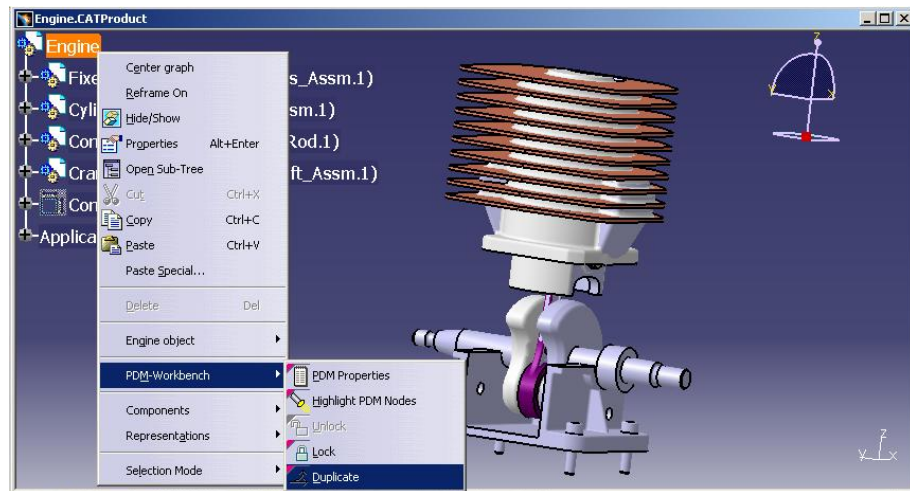

Picture 65: Action "Duplicate"

The "PDM Create" dialog will be opened. The correct type is already selected. The identifying name of the document is filled, too.

You have to fill or change the attributes (see *Picture 66: "PDM Create" dialog for duplicate*). The CATIA object has the temporary suffix "-DUPLICATE".

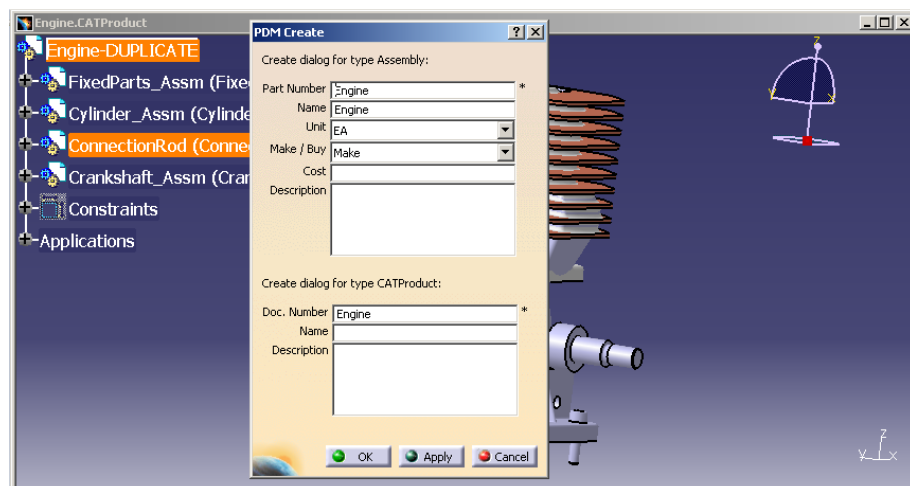

Picture 66: "PDM Create" dialog for duplicate

When you close the dialog with "OK" (see *Picture 67: Filled "PDM Create" dialog for duplicate*) the CATIA document will be renamed to the new part number and created in the PDM system (see *Picture 68: Duplicated CATProduct object*).

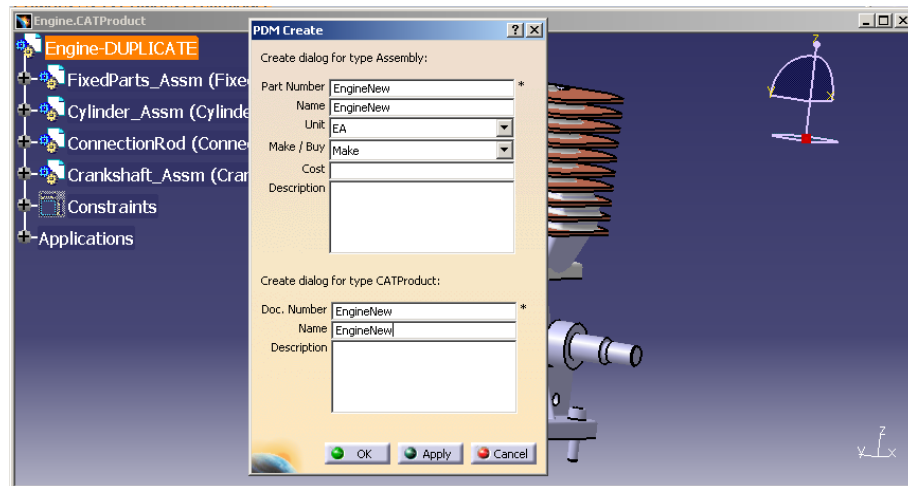

Picture 67: Filled "PDM Create" dialog for duplicate

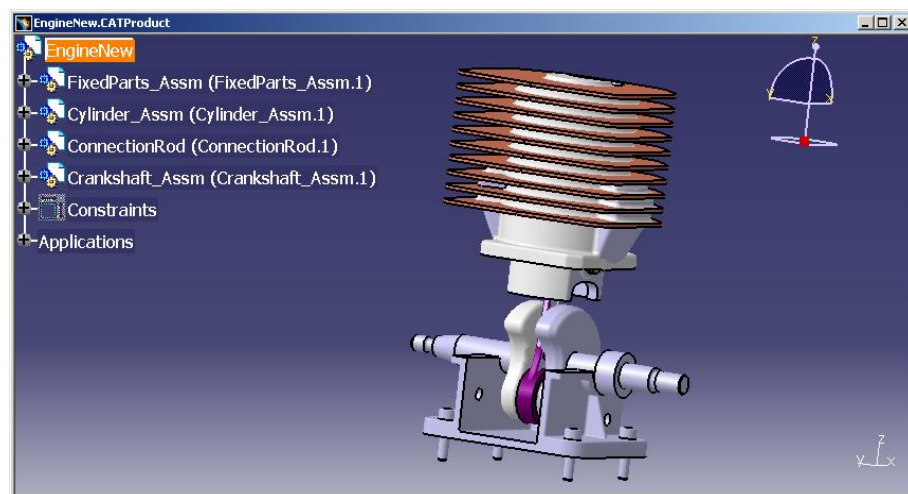

Picture 68: Duplicated CATProduct object

When a CATDrawing object is related to the CATProduct and the file name and the document name of the CATDrawing ("Product-No-100-Drawing.CATDrawing ") includes the part number of the CATProduct ("Product-No-100") as prefix then the CATDrawing can be duplicated and related to the CATProduct.

You load the product structure with the drawing. They are opened in two CATIA windows. Then you select the top product and open the context menu and select the action "Duplicate". The product will be renamed with the suffix "-DUPLICATE" and the "PDM Create" dialog will be opened. The document name is filled (see *Picture 69: "PDM Create" dialog for Assembly and CATProduct*).

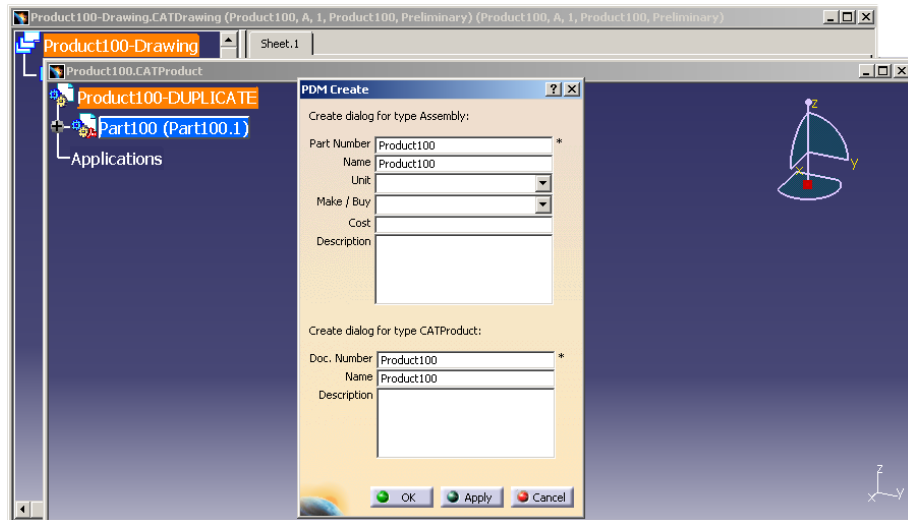

Picture 69: "PDM Create" dialog for Assembly and CATProduct

You change and fill the dialog and select the "OK" button (see *Picture 70: Filled "PDM Create" dialog for Assembly and CATProduct*).

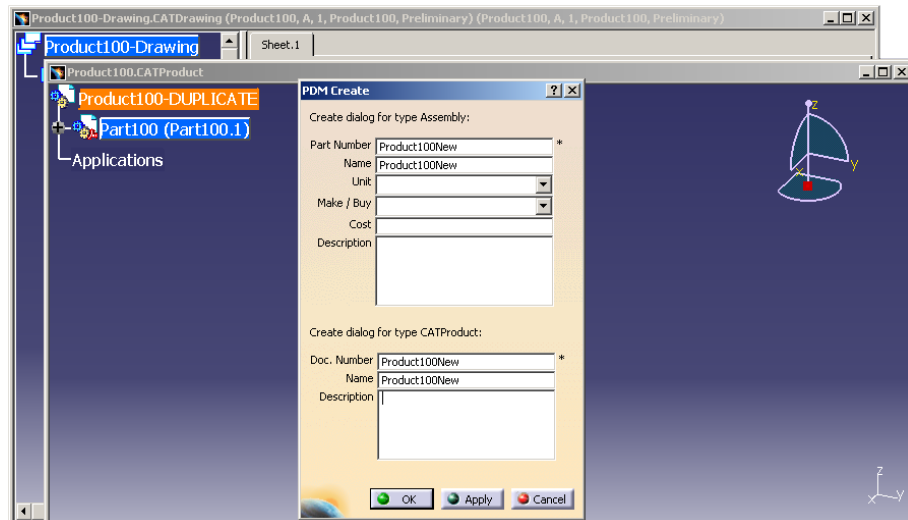

Picture 70: Filled "PDM Create" dialog for Assembly and CATProduct

The CATProduct will be renamed to the desired name and created in the PDM system. The "PDM Create" dialog for the CATDrawing will be opened. The part number and the name of the assembly are filled. The action is set to "Duplicate Part" (see *Picture 71: "PDM Create" dialog for Assembly and CATDrawing*).

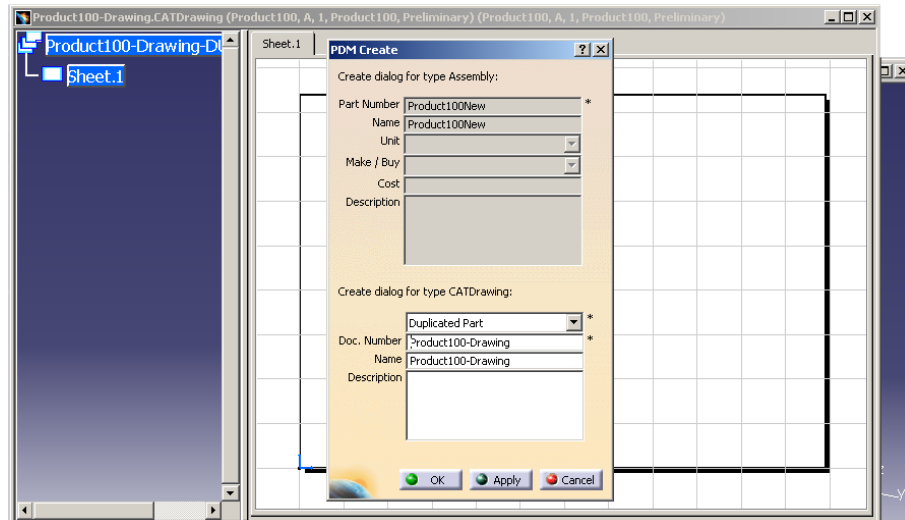

Picture 71: "PDM Create" dialog for Assembly and CATDrawing

You change and fill the dialog. The Document Name should have the Part Number of the Assembly as prefix. Then you start the process with the "OK" button (see *Picture 72: Duplicated CATProduct object*).

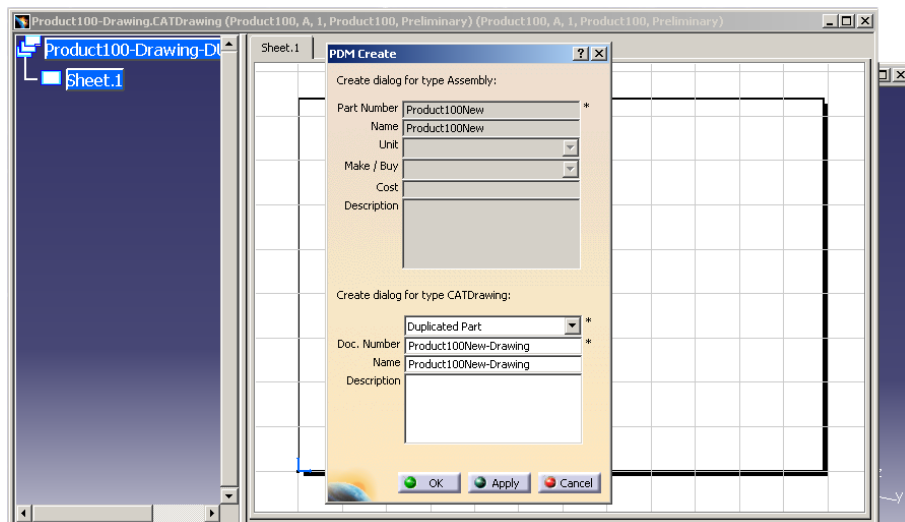

Picture 72: Duplicated CATProduct object

The drawing document will be created in the PDM system and related to the assembly object. Analogous you can duplicate a CATPart with its CATDrawing.

Create Relation between windows

You might modify the product structure by adding existing objects from several PDM-Workbench windows to the structure in another PDM-Workbench window.

You select the object you want to copy and click the right mouse button to get the context menu. Then you select the context action "Copy" (see *Picture 73: Action "Copy" between windows*). Of course you also can use the short cut "CTRL+C".

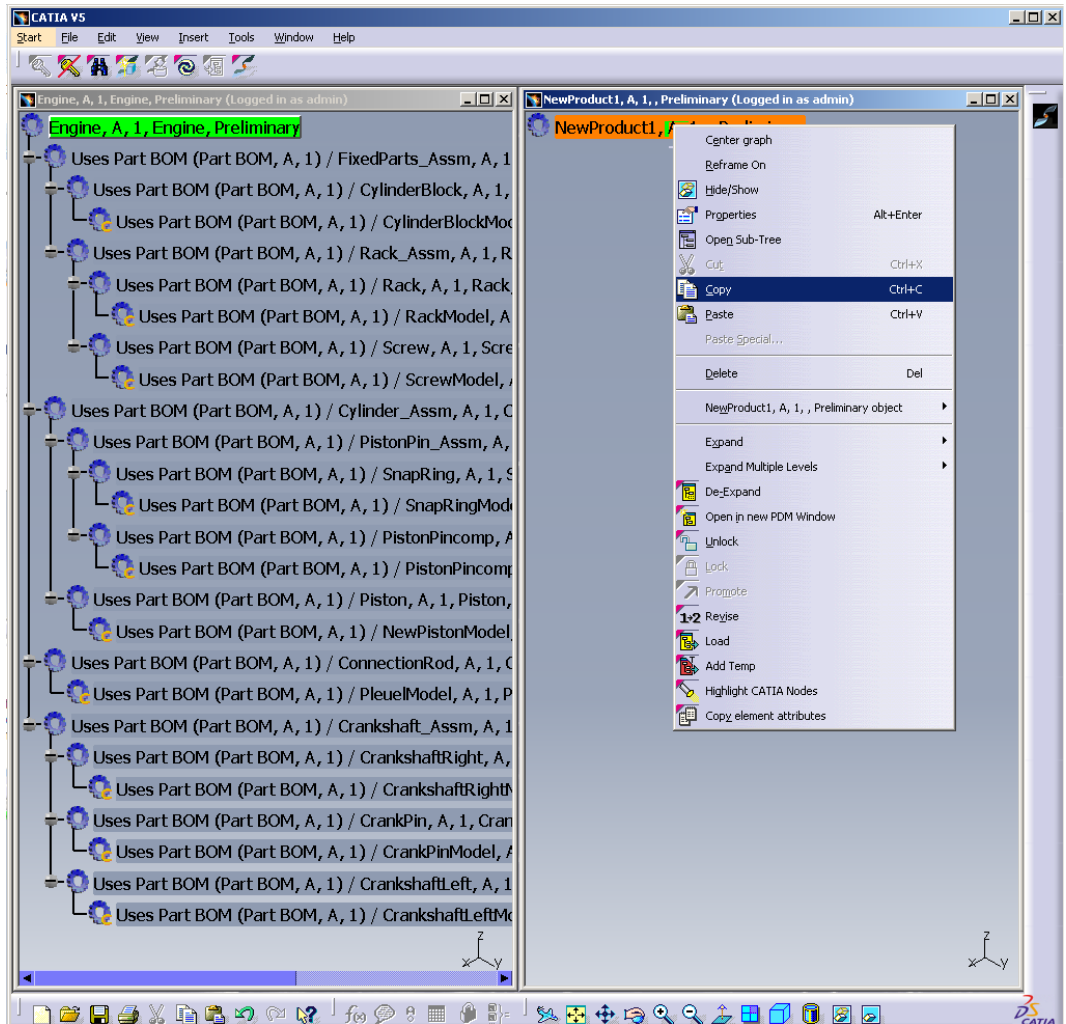

Picture 73: Action “Copy” between windows

Then you select the object where you want to add the copied object to and click the right mouse button to open the context menu. You select the context action “Paste” (see *Picture 74: Action “Paste” between windows*). Of course you also can use the short cut “CTRL+V”.

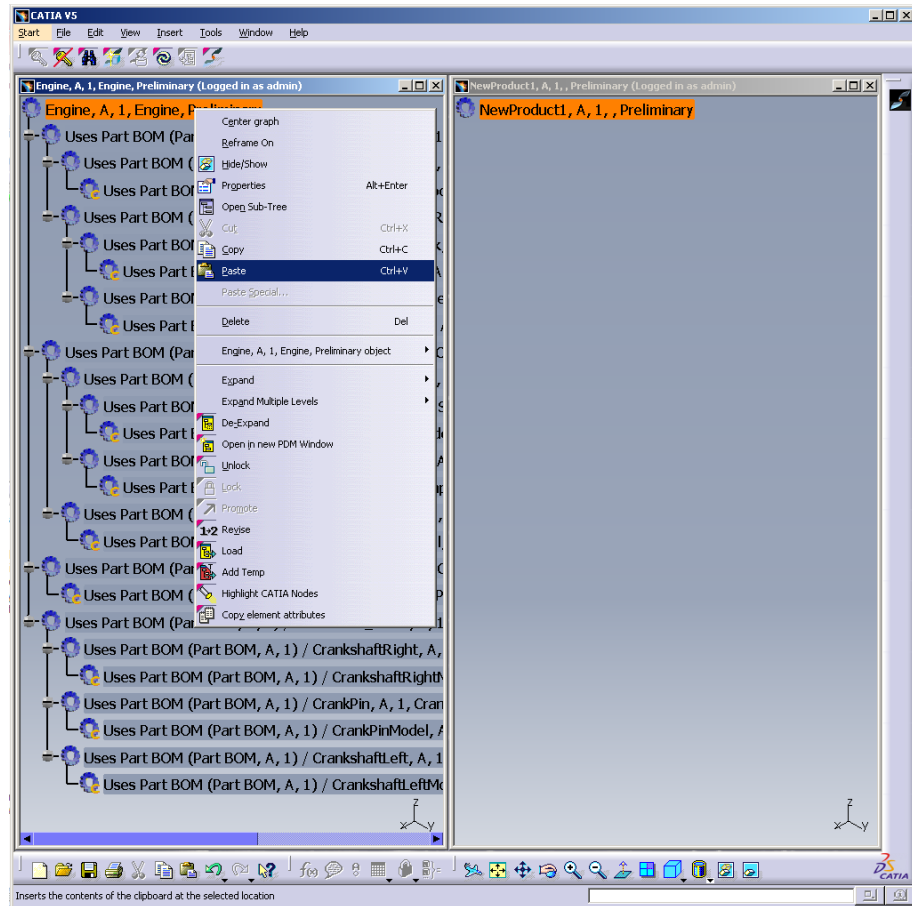

Picture 74: Action “Paste” between windows

You specify the relation you want to create in the structure between the two objects (see *Picture 75: Select the new relation*) once there is more than one relation type available. In the dialog window you see all relations possible between the two objects. In case you want to add the Assembly object in the structure to another Assembly object then you might choose the “Part BOM” relation for example. The dialog will not appear if there is only one relation type available.

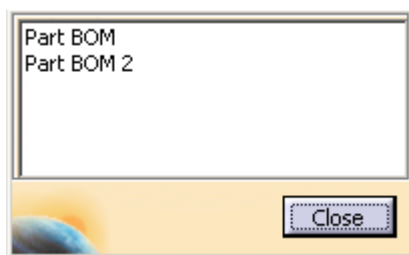

Picture 75: Select the new relation

The instance object gets inserted into the existing product structure tree and the new relation gets created in the PDM system (see *Picture 76: Product Structure with inserted object*).

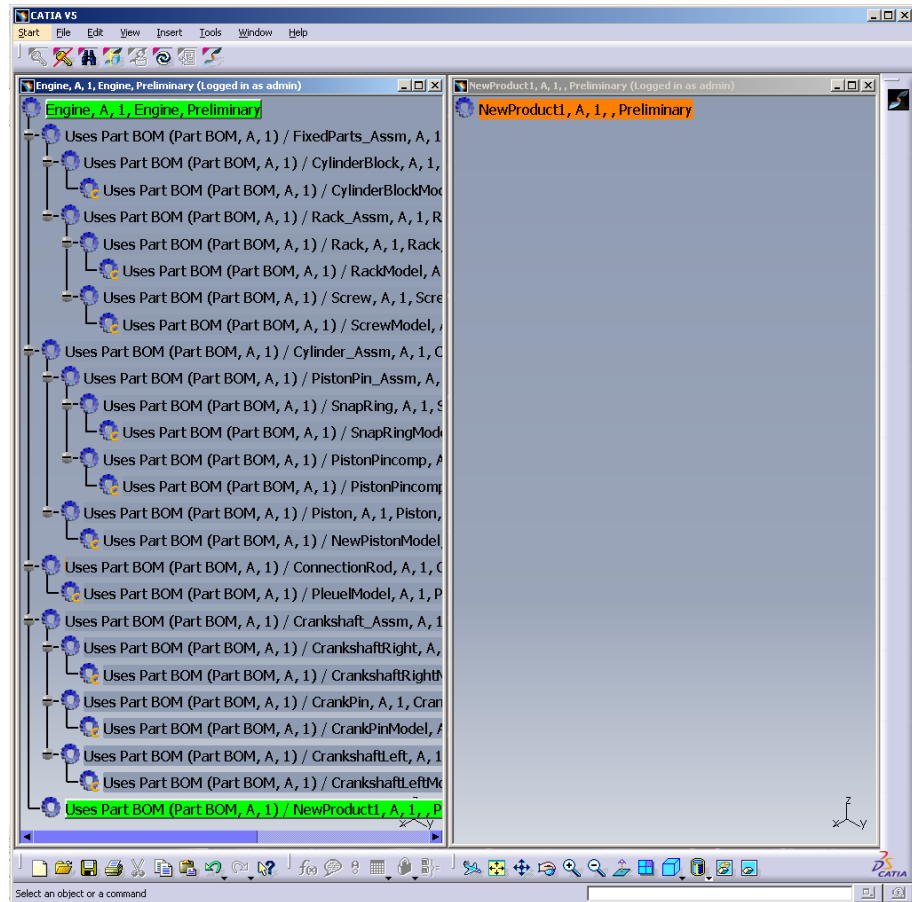

Picture 76: Product Structure with inserted object

Update

The Update functionality can be used to create, to complete, or to update the product structure in the PDM system based on the geometry in the CATIA V5 window.

You can start the Update process by clicking on the “Update” icon .

A dialog opens and asks to confirm the described actions. In this example the CATIA documents will be created (see *Picture 77: Confirm the Update (with Create) action*).

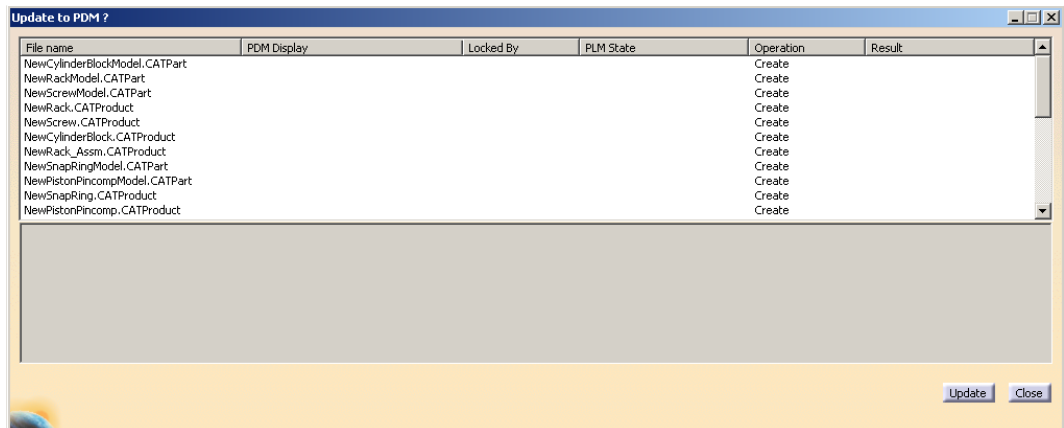

Picture 77: Confirm the Update (with Create) action

The progress of the Update will be shown with the progress bars (see *Picture 78: Progress bars for Update action*).

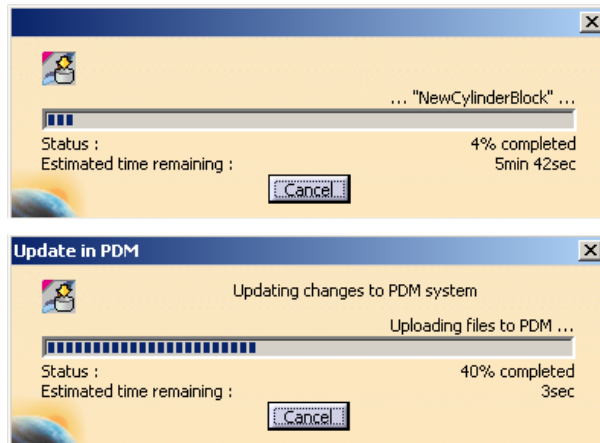

Picture 78: Progress bars for Update action

When the Update process has finished you are informed about the actions that have been performed. The related instances and the created objects are reported in the information window (see *Picture 79: Information window when Update (with Create) is finished*).

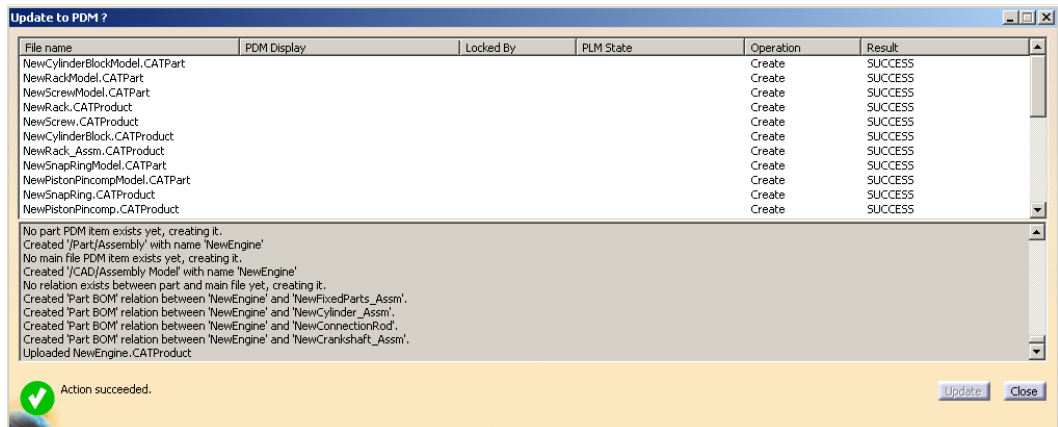

Picture 79: Information window when Update (with Create) is finished

If there are no objects to be created then it will only be asked if you want to update (see *Picture 80: Confirm the Update action*).

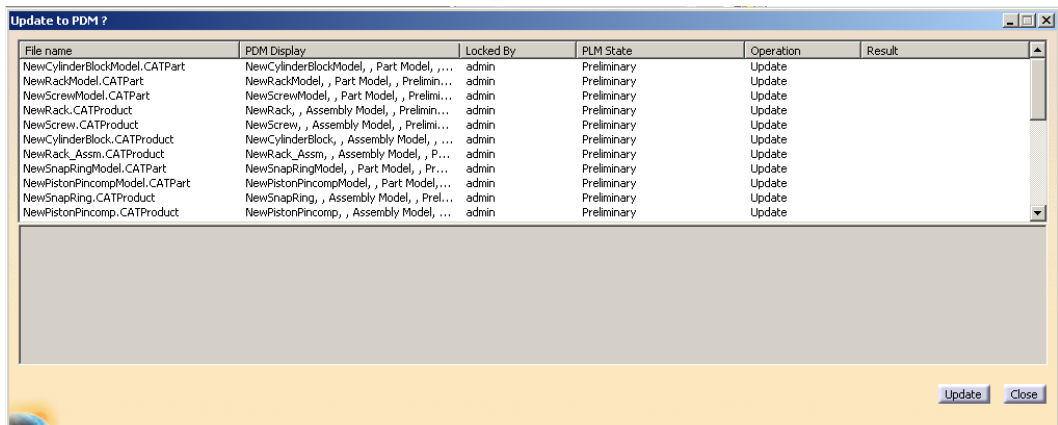

Picture 80: Confirm the Update action

When the Update process has finished you are informed about the actions that have been performed (see *Picture 81: Information window when Update is finished*).

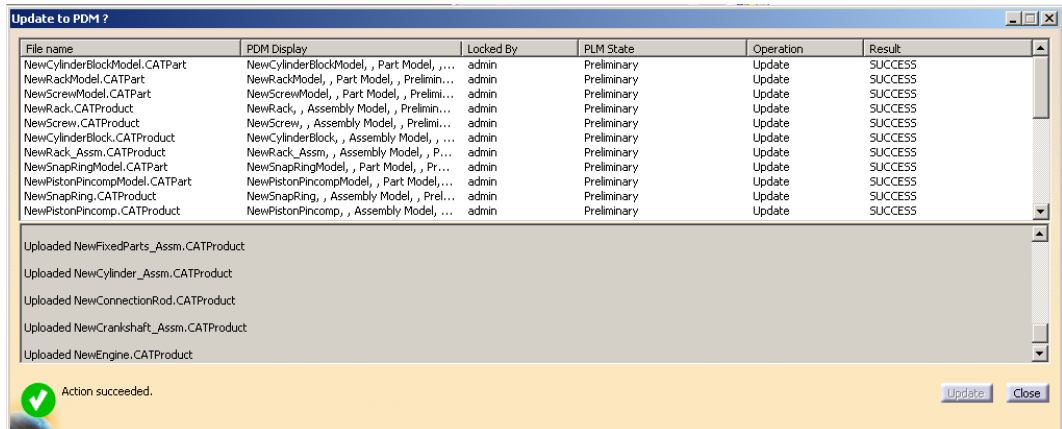

Picture 81: Information window when Update is finished

Show PDM Structure

When you have opened the geometry in CATIA V5 you have the possibility to show the corresponding PDM product structure.

For this you have to click on the “PDM Structure” icon . Then a PDM-Workbench window with the PDM product structure will be opened (see *Picture 82: PDM Structure for geometry*).

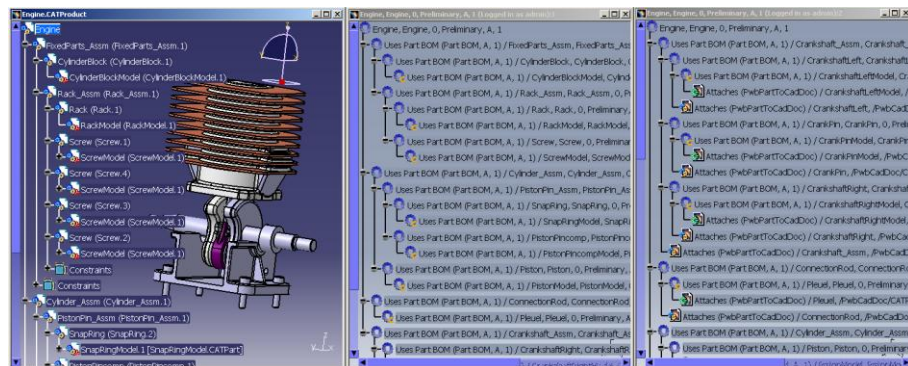

Picture 82: PDM Structure for geometry

Please note that with BOM-part structures, the expanded part structure (window in the middle) usually does not contain the related CATIA files, but the structure displayed by “Show PDM Structure” does (right window).

Refresh PDM Structure

When you have made some actions on the geometry that have an impact on the status of the objects in the PDM product structure, that are not displayed automatically, then you have to update the status display manually.

After the load of the geometry the status of the objects of the PDM product structure is in the default state.

There are the following possible states:

- No background color: not owned by session user, no changes
- Green: owned by session user, no changes
- Yellow: owned by session user, dirty because of changes
- Red: not owned by session user, dirty because of changes
- Black: the object is finalized in the PDM (for example: released state)
- White: the object does not have the file in the PDM

The CATIA Part is owned by the session user and no changes. It is marked in green (see *Picture 83: PDM Structure and geometry in CATIA V5*).

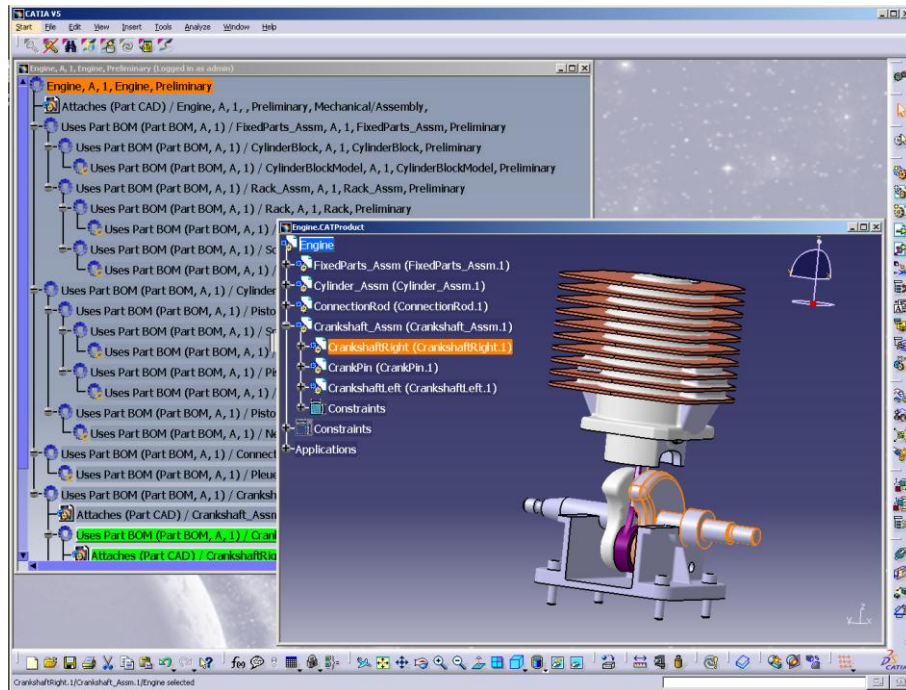

Picture 83: PDM Structure and geometry in CATIA V5

In the CATIA V5 you can make some changes in the geometry (see *Picture 84: Making changes in the geometry*) that make the objects in the PDM product structure dirty. This state change will not be displayed automatically.

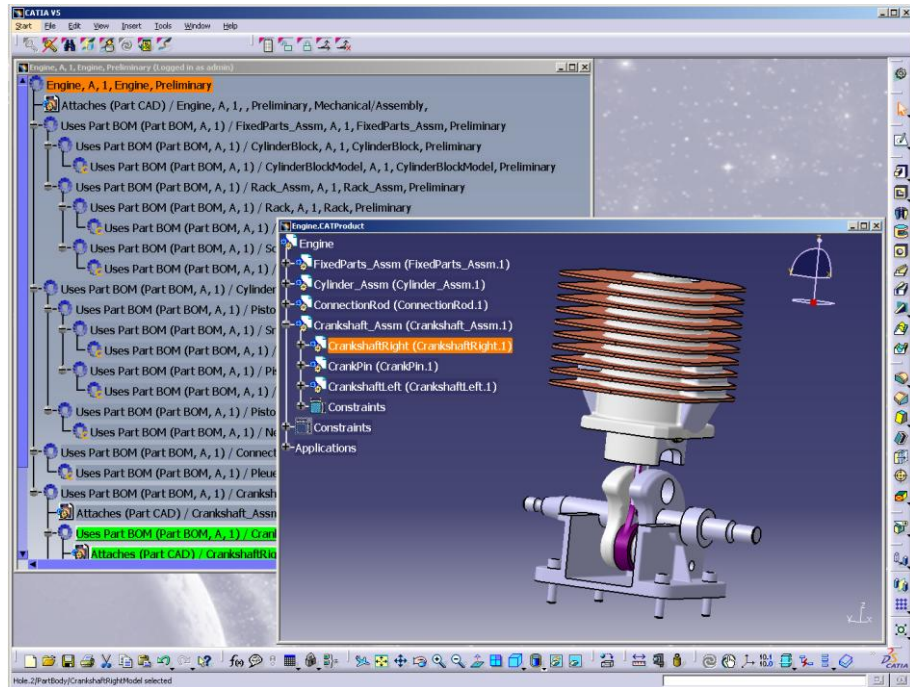

Picture 84: Making changes in the geometry

In order to display the changes you have to click on the “Refresh PDM Structure” icon . Then the status of the changed objects in the PDM product structure will be updated.

Now e.g. the dirty object owned by the session user will be displayed in yellow in the PDM product structure. The dirty objects on the way to the root are displayed in red because they are not owned by the session user (see *Picture 85: Refreshed PDM Structure*).

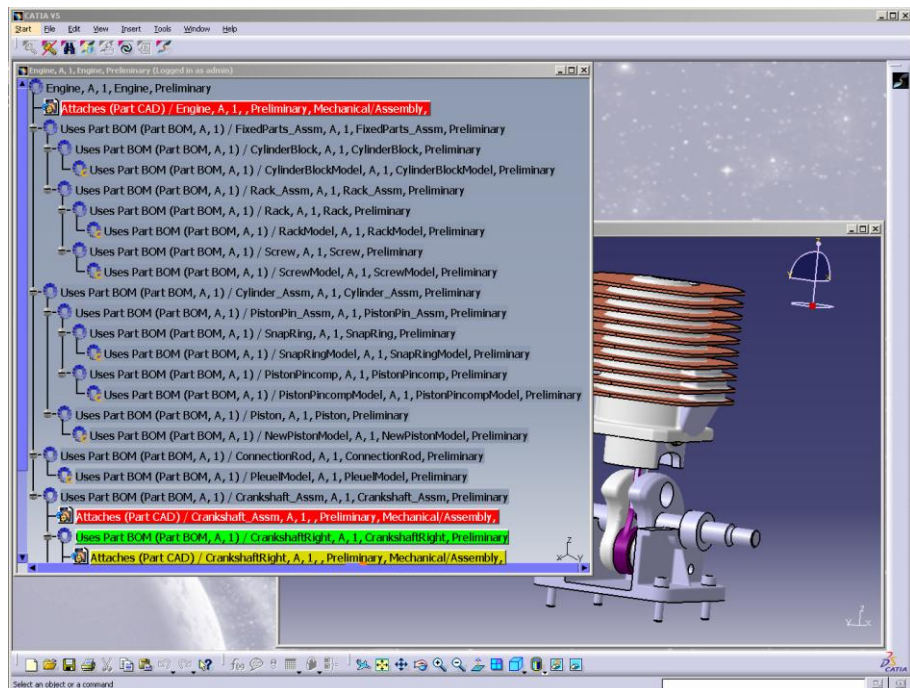

Picture 85: Refreshed PDM Structure

Force Load CATPart

When you have loaded the CATIA node into the structure via the Desk command because the file could not be loaded then you can load the CATIA data with the required PDM-Workbench information. For this you have to select the CATIA node and open the context menu. Then choose “PDM-Workbench→Force Load CATPart” (see *Picture 86: Action "Force Load CATPart"*).

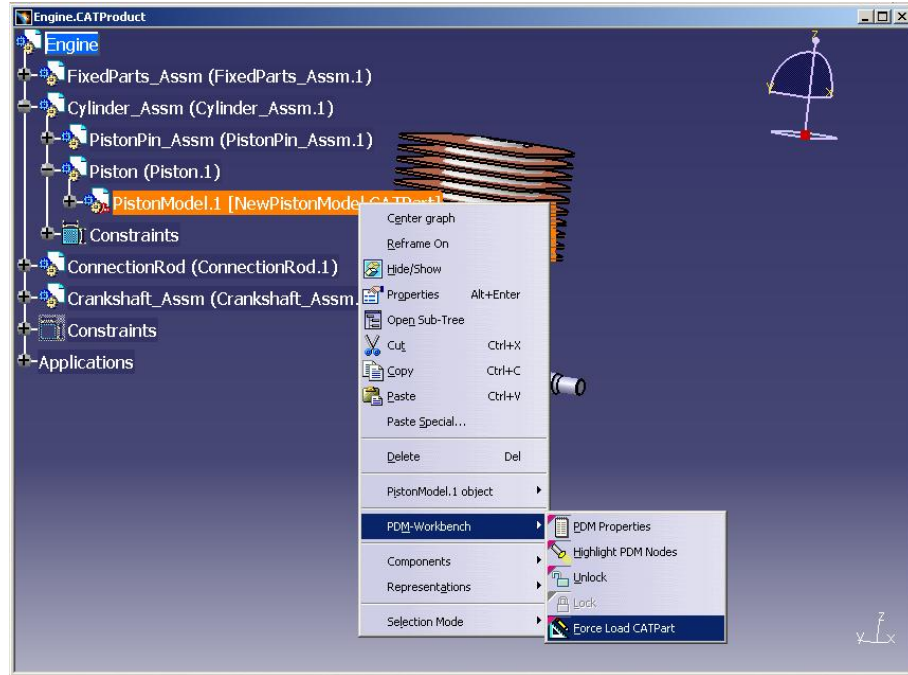

Picture 86: Action "Force Load CATPart"

Highlight PDM Nodes

Sometimes it is important to find a PDM node when you are working on the corresponding object in the geometry, e.g. in order to lock the PDM object. Or you have selected an object in the PDM product structure and want to see the corresponding object in the geometry.

For this you can select an object in the geometry and click on the right mouse button. The context menu opens and you have to choose “PDM-Workbench→Highlight PDM Nodes” (see *Picture 87: Action "Highlight PDM Nodes"*).

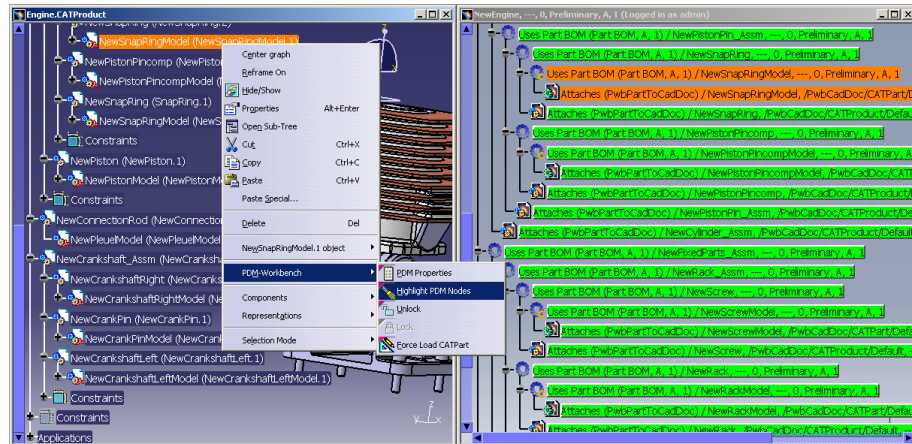

Picture 87: Action “Highlight PDM Nodes”

The PDM-Workbench window will be displayed in the foreground and the objects that correspond to the selection in the geometry will be highlighted (marked) (see *Picture 88: Highlighted nodes in PDM Structure*). If there is no PDM-Workbench window opened you will get a warning that you have to open the PDM structure first. It is important that you have only one PDM Structure window for this Part Number.

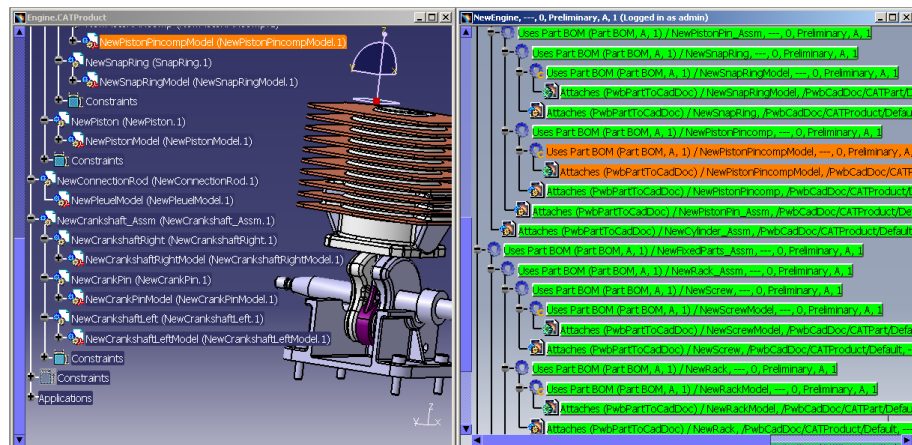

Picture 88: Highlighted nodes in PDM Structure

This works in the opposite direction, too (see *Highlight CATIA Nodes*).

Highlight CATIA Nodes

Sometimes it is important to find a CATIA node when you are working on the corresponding object in the product structure, e.g. in order to lock the PDM object. Or you have selected an object in the geometry and want to see the corresponding object in the PDM product structure.

For this you can select an object in the PDM product structure and click on the right mouse button. The context menu opens and you have to choose “PDM-Workbench→Highlight CATIA Nodes” (see *Picture 89: Action “Highlight CATIA Nodes”*).

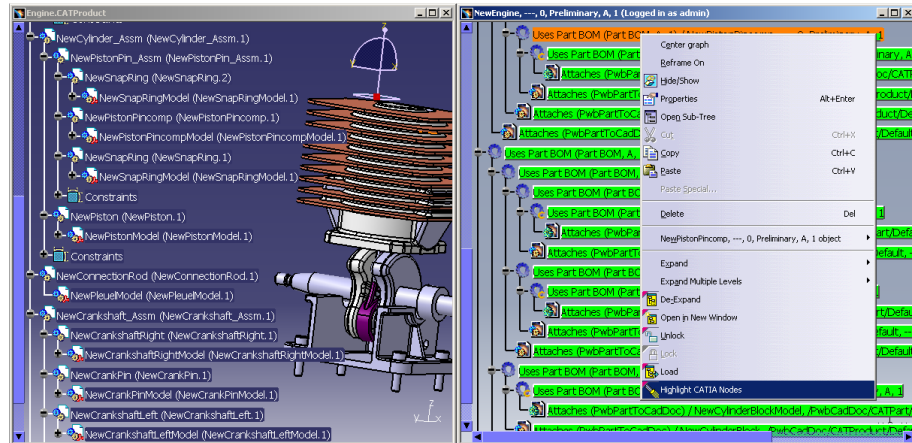

Picture 89: Action “Highlight CATIA Nodes”

The CATIA V5 geometry window will be displayed in the foreground and the objects that correspond to the selection in the PDM product structure will be highlighted (marked) (see *Picture 90: Highlighted nodes in CATIA geometry*). If there is no CATIA V5 geometry window opened you will get a warning that you have to open the CATIA V5 geometry window.

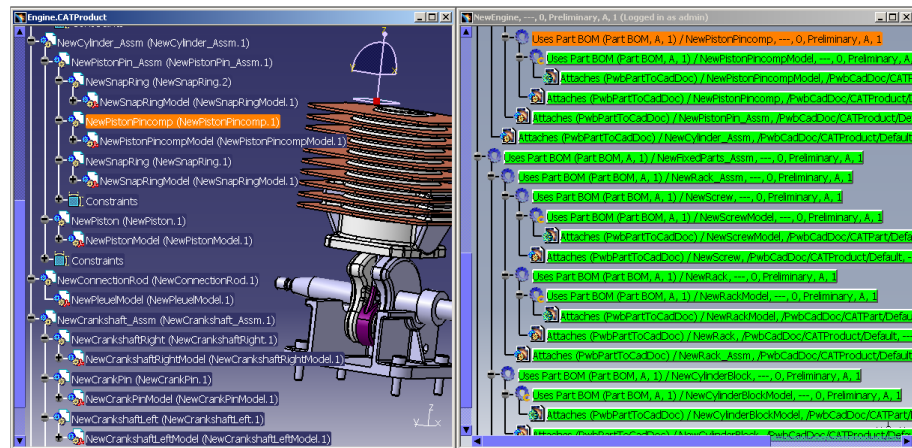

Picture 90: Highlighted nodes in CATIA geometry

This works in the opposite direction, too (see *Highlight PDM Nodes*).

Open in New Window

When you have a lot of objects in one window, e.g. received by query or expand then it can be necessary to open a subset of them in a new window.

You select the objects you want to open in a new window. In the context menu you select the action “Open in New Window” (see *Picture 91: Action “Open in New Window”*).

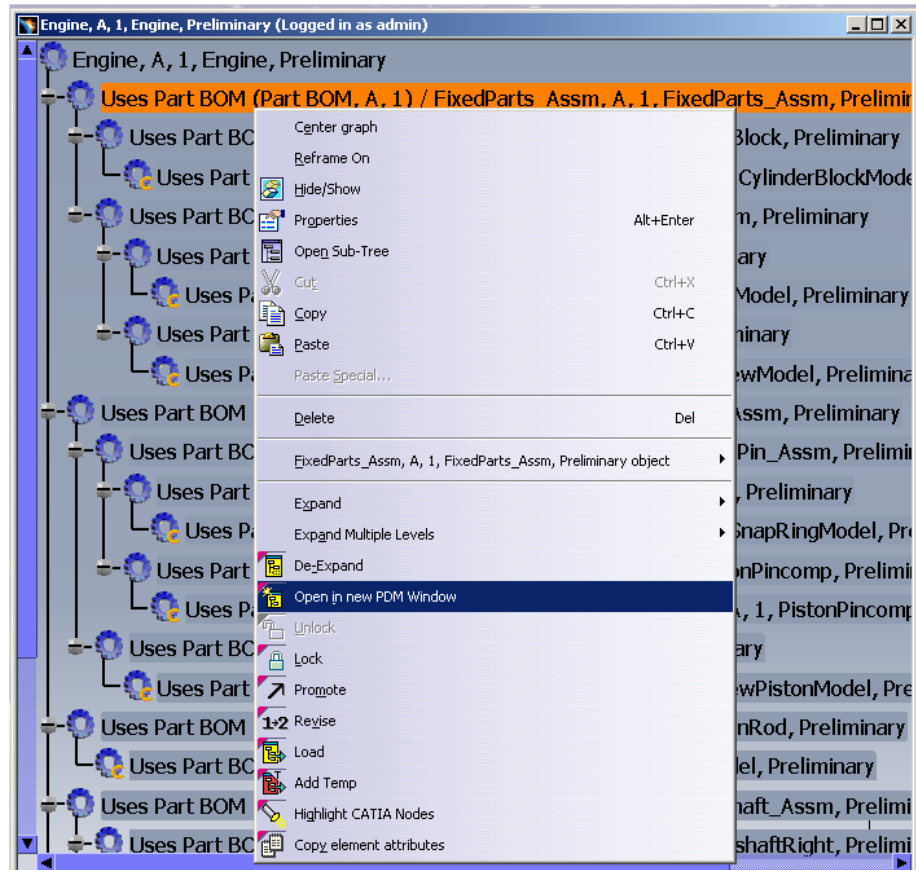

Picture 91: Action “Open in New Window”

The selected objects will be opened in a new window (see *Picture 92: The selected objects in the new window*).

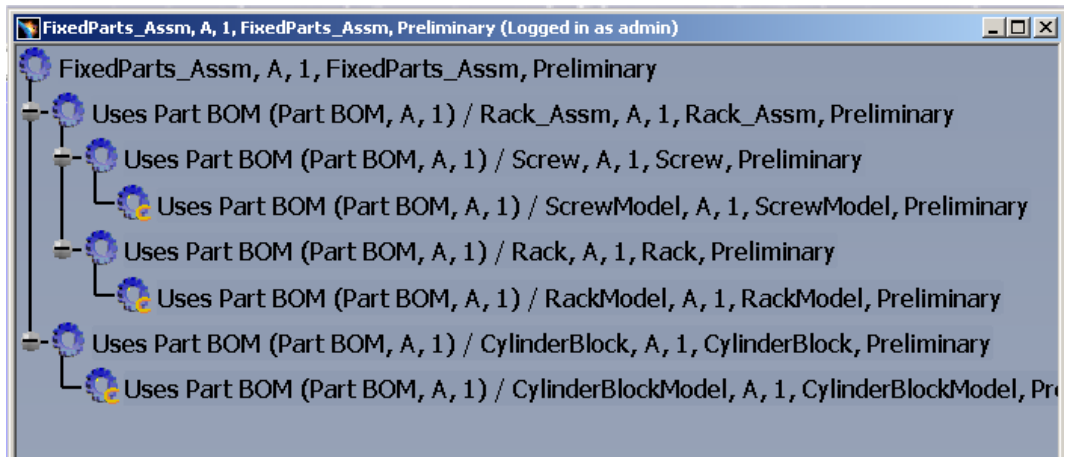

Picture 92: The selected objects in the new window

Attribute mapping functionality

CATIA standard and user-defined properties can be mapped to PDM attributes.

In the following example the standard CATIA attributes “Nomenclature” and “Description” are mapped to the attributes “name” and “description” of the Aras Innovator part object (see *Picture 93: Standard attributes in the “Properties” dialog* and *Picture 94: Configuration of standard attributes in Aras Innovator*).

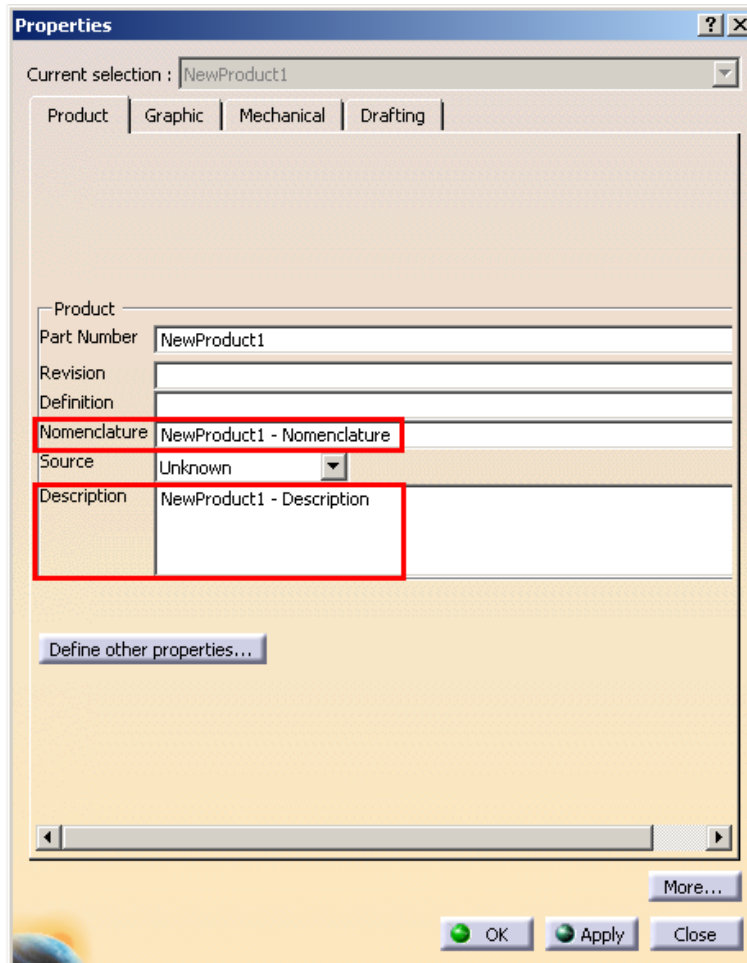

Picture 93: Standard attributes in the “Properties” dialog

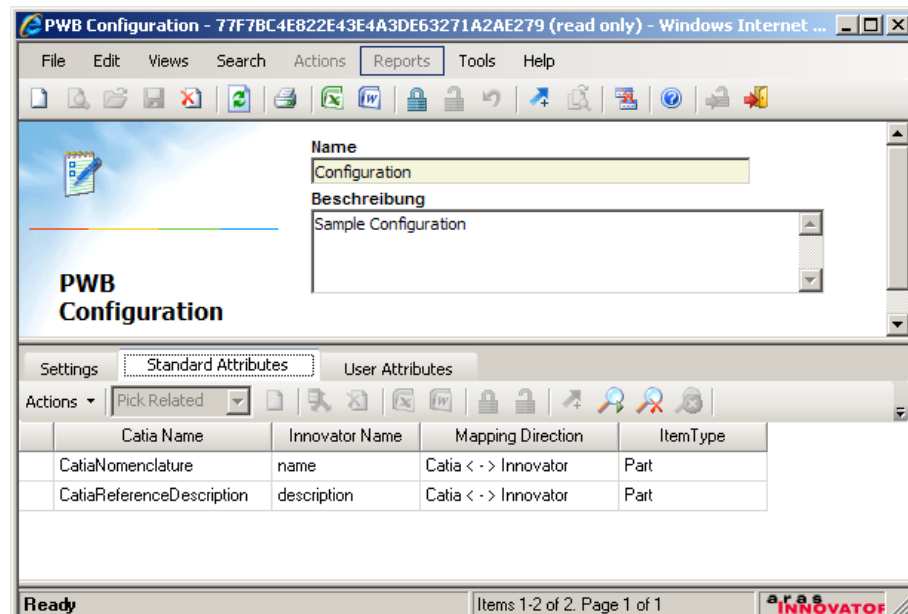

Picture 94: Configuration of standard attributes in Aras Innovator

After creating the part with Update the defined CATIA attribute values have been written to the PDM part object (see *Picture 95: Standard attributes in the “Properties” dialog of the PDM node* and *Picture 96: Standard attributes in Aras Innovator window*).

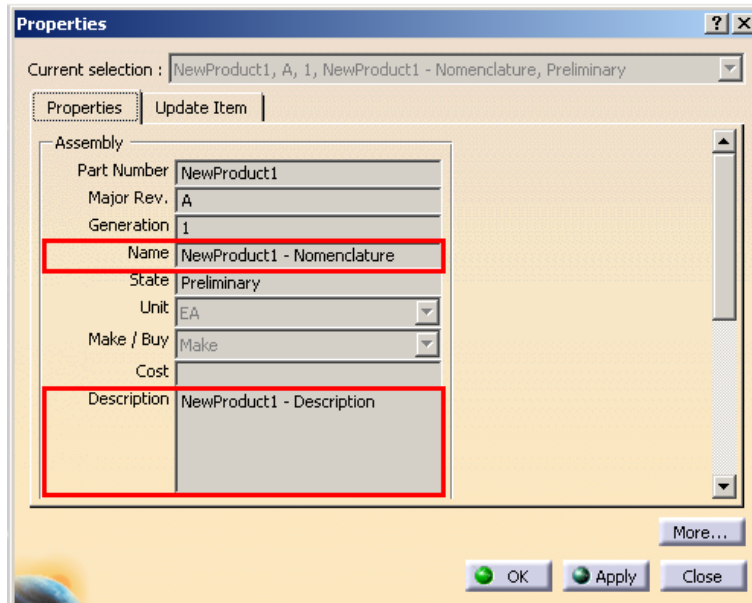

Picture 95: Standard attributes in the “Properties” dialog of the PDM node

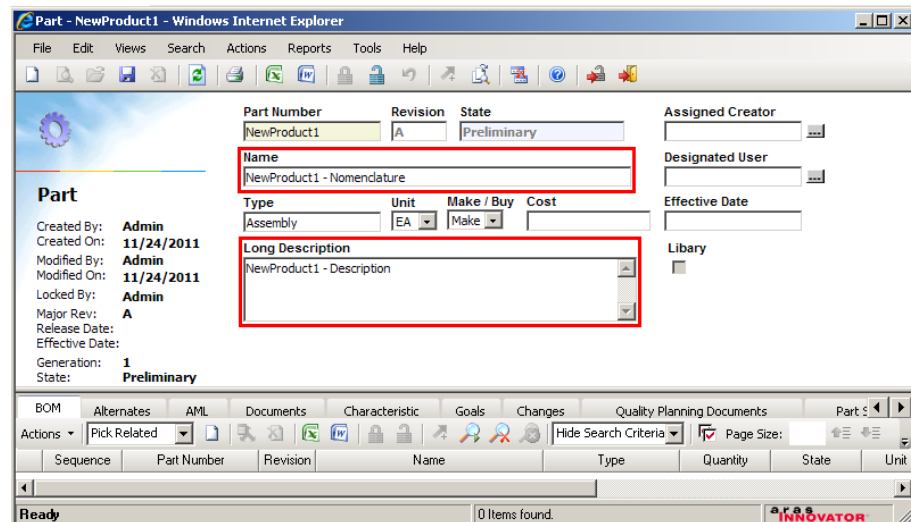

Picture 96: Standard attributes in Aras Innovator window

User-defined CATIA properties can also be mapped (see *Picture 97: Configuration of user-defined attributes in Aras Innovator*).

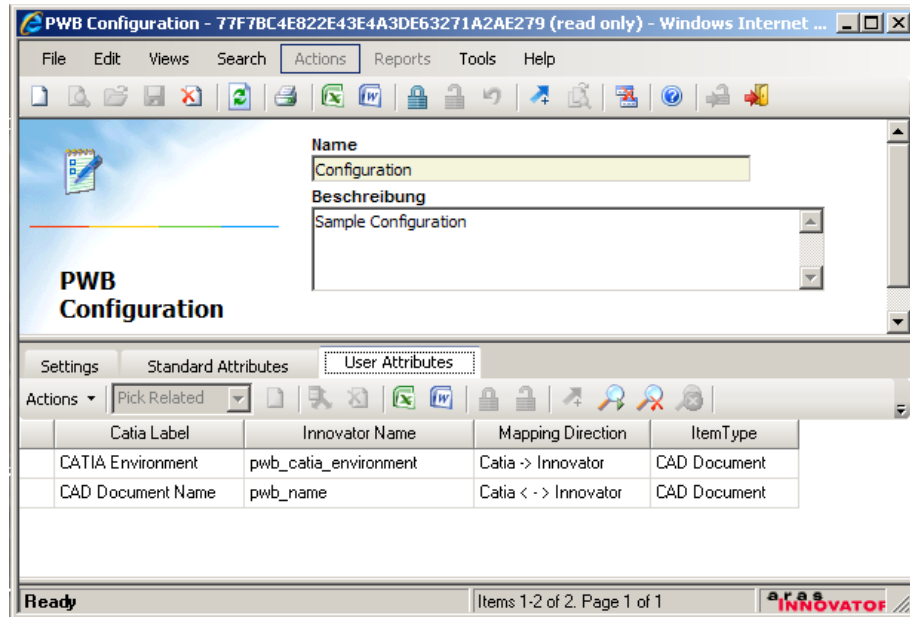

Picture 97: Configuration of user-defined attributes in Aras Innovator

While the structure is imported the values are written to the defined attributes of the Aras Innovator CAD document object (see *Picture 98: User-defined attributes in the "Properties" dialog of the PDM node* and *Picture 99: User-defined attributes in Aras Innovator window*).

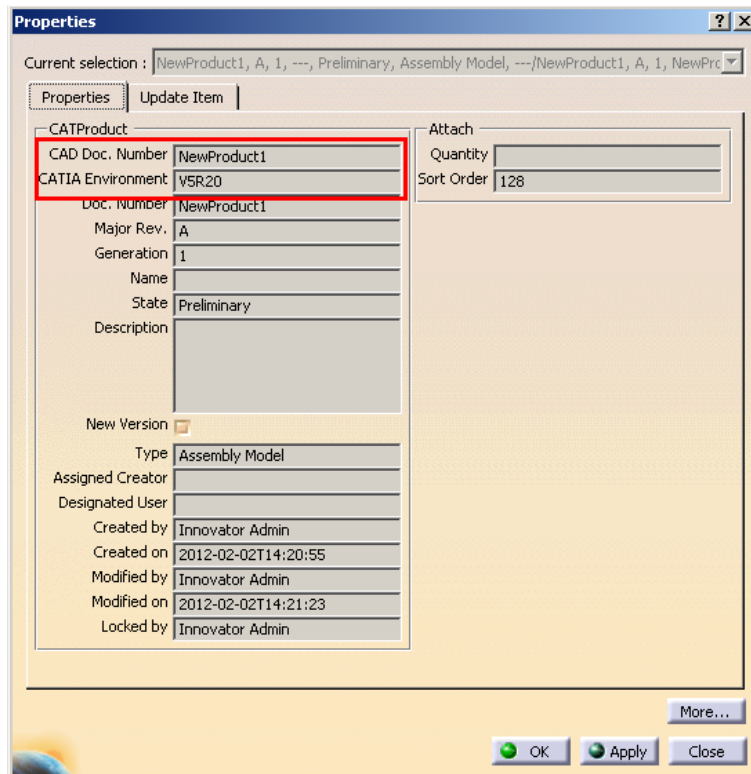

Picture 98: User-defined attributes in the "Properties" dialog of the PDM node

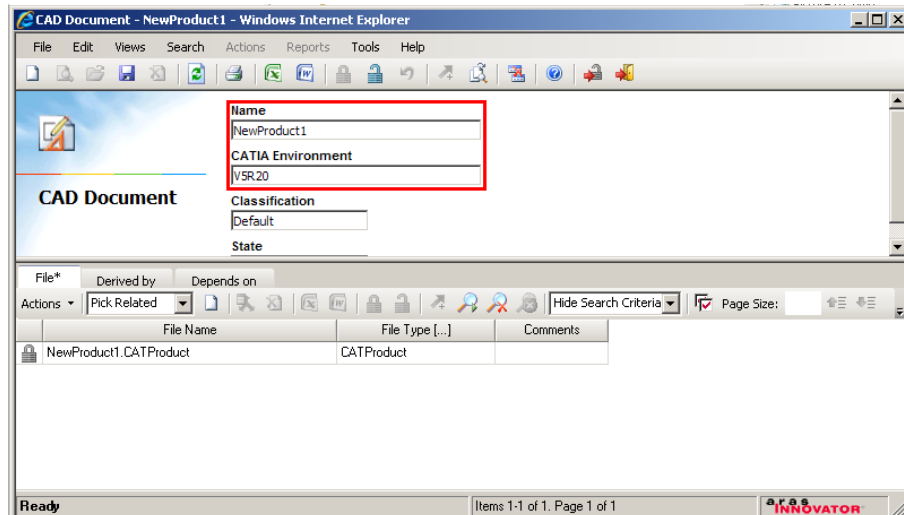

Picture 99: User-defined attributes in Aras Innovator window

After the import or after loading the structure it can be shown that the values are written from the PDM attributes into the CATIA files (see *Picture 100: User-defined attributes in the "Properties" dialog*).

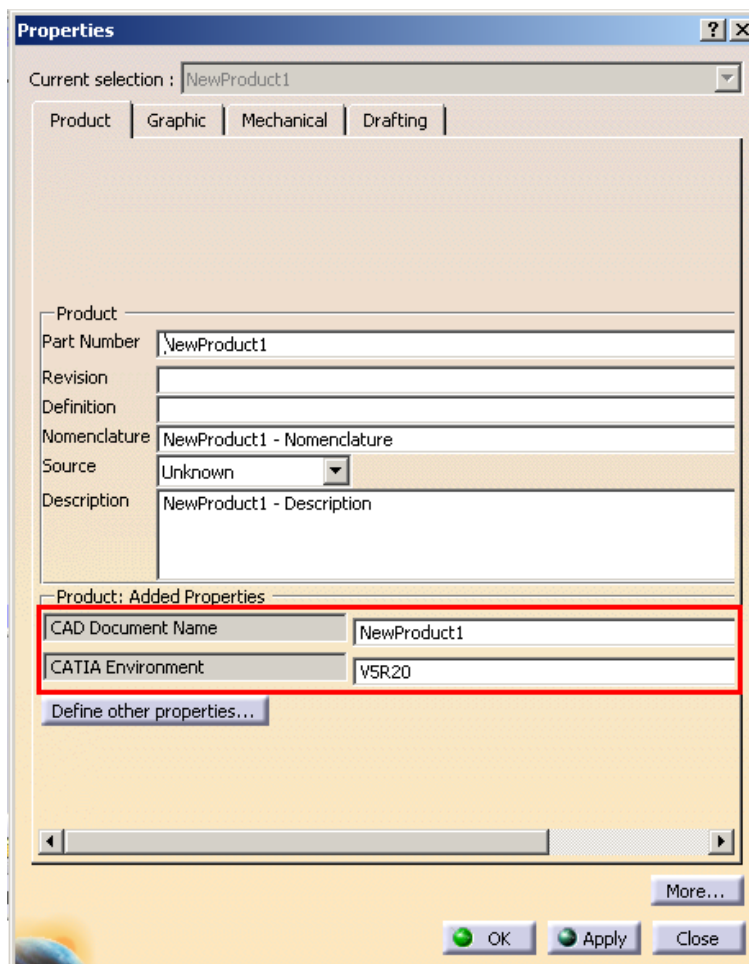

Picture 100: User-defined attributes in the "Properties" dialog

Internal CATIA information can be written to user-defined CATIA properties

If they are defined this way then the corresponding current values are written into the user-defined CATIA properties (see *Picture 101: User-defined attributes with internal CATIA information in the “Properties” dialog*).

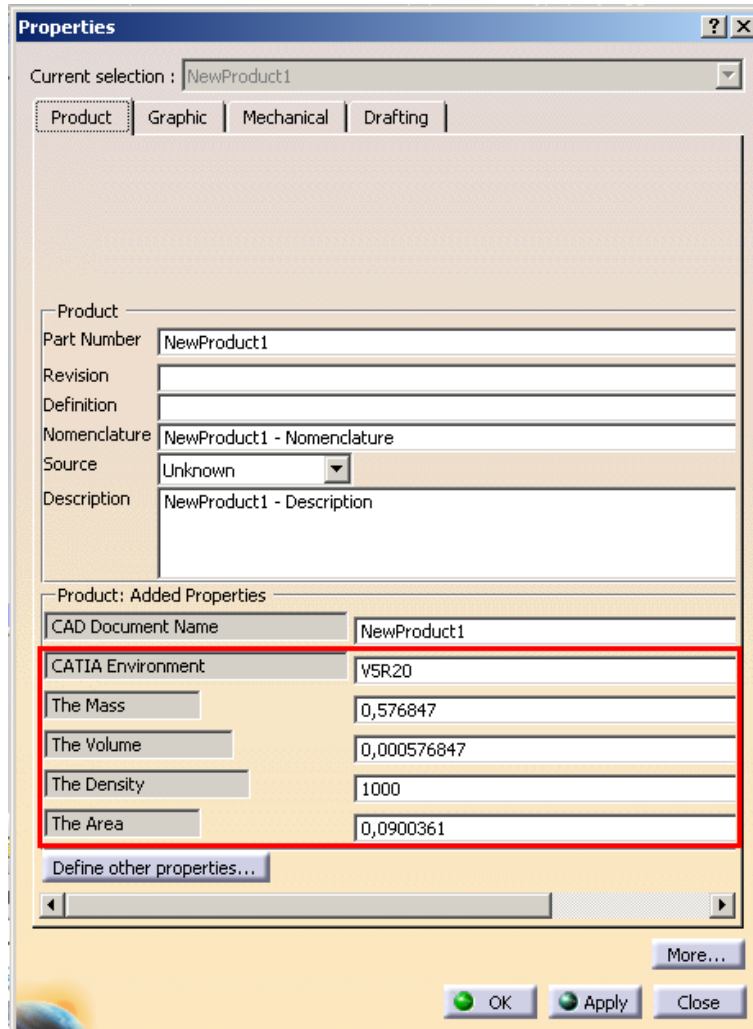

Picture 101: User-defined attributes with internal CATIA information in the “Properties” dialog

If these values are configured correspondingly, like for instance “CATIA Environment” in the picture below, then the values are automatically written to the mapped attributes of the PDM object (see *Picture 102: Configuration of user-defined attributes in Aras Innovator*).

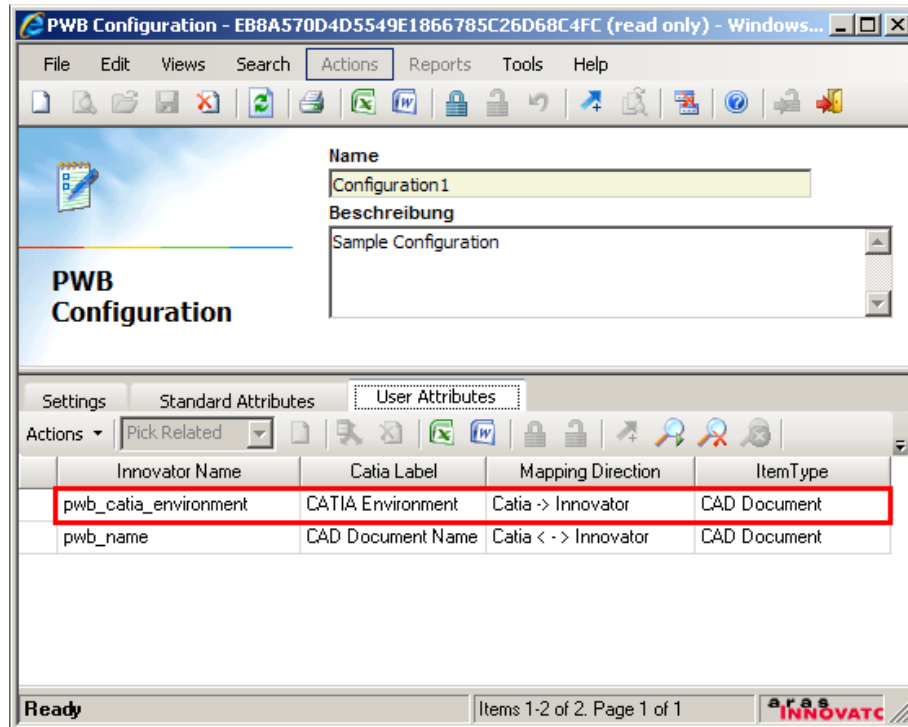

Picture 102: Configuration of user-defined attributes in Aras Innovator

Template-based CAD document and part creation

In the dialog which appears after the user clicks on the toolbar action “Create”  the type of the new object can be selected (see *Picture 103: Select a PDM type for the “Create” dialog*).

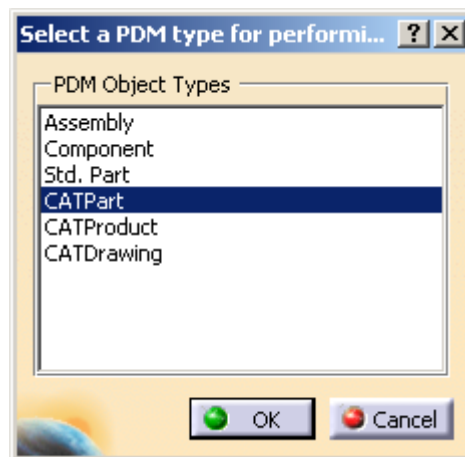

Picture 103: Select a PDM type for the “Create” dialog

If one of those types is selected then the next dialog opens. You have to select the template for the new object from a dropdown list. The template names are defined in the PDM-Workbench Schema File. If you do not select a template an empty CATIA file is opened (see *Picture 104: “Create” dialog for CATPart – Select Template*).

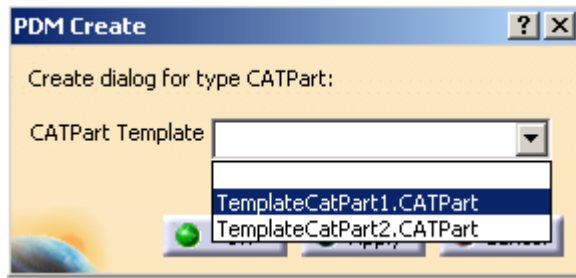

Picture 104: “Create” dialog for CATPart – Select Template

When you confirm the dialog with "OK" the template file or the empty file is opened in CATIA and the "Update to PDM?" dialog is opened. You have to type in the attribute values of the item object and the document object to be created (see *Picture 105: “Create” dialog for CATPart*).

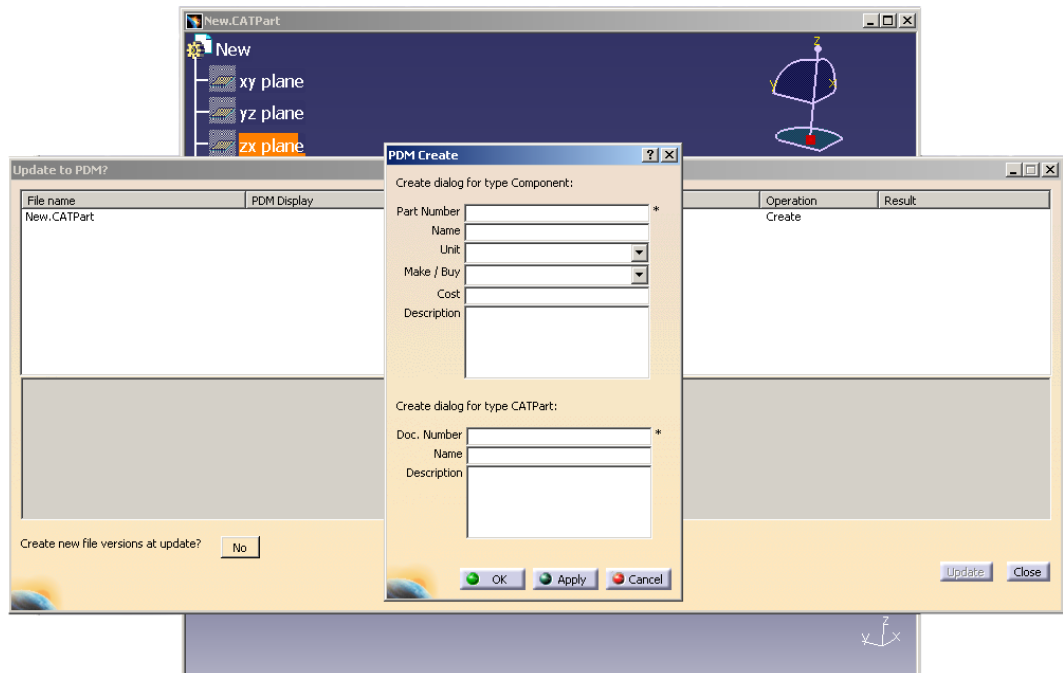

Picture 105: “Create” dialog for CATPart

Then you have to click on the “OK” button. A normal update is performed, which creates a part with the corresponding CAD document in the PDM system and uploads the file (see *Picture 106: Created Part*).

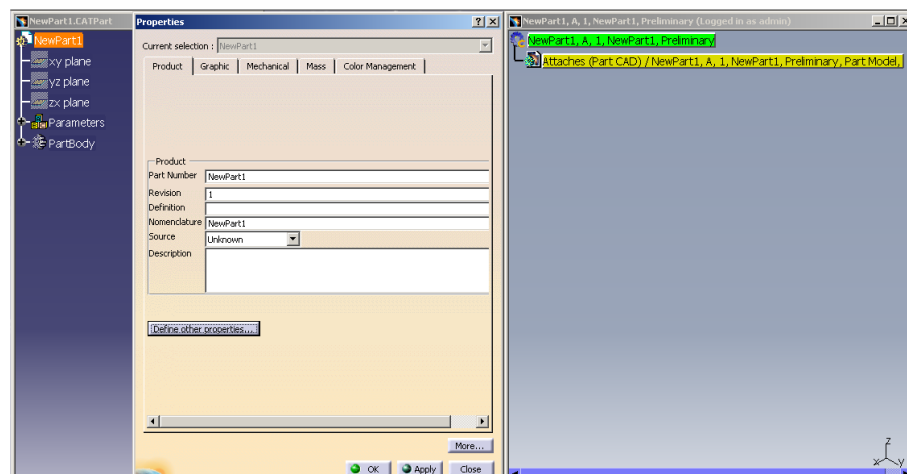

Picture 106: Created Part

Copy element attributes

It is possible to copy the attributes from a PDM object in order to use them in a create dialog.

You can select a PDM object in the PDM window and click on the right mouse button. Then you select the action "Copy element attributes" (see *Picture 107: Action "Copy element attributes"*).

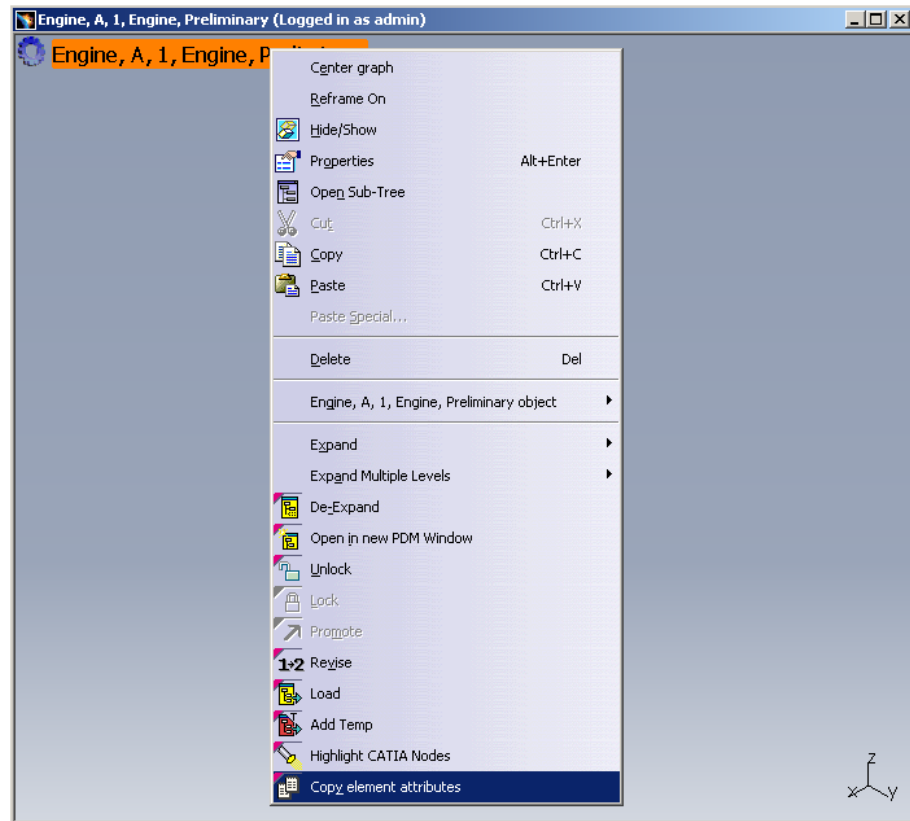

Picture 107: Action "Copy element attributes"

The attributes will be copied to the clipboard.

In the next step you select the action "Create" from the toolbar and select the corresponding class for the object to be created, in this case "Assembly" for the copied attributes of the "Engine". The create dialog will be opened. It has the button "Insert attribute values" (see *Picture 108: "Create" dialog for Assembly*).

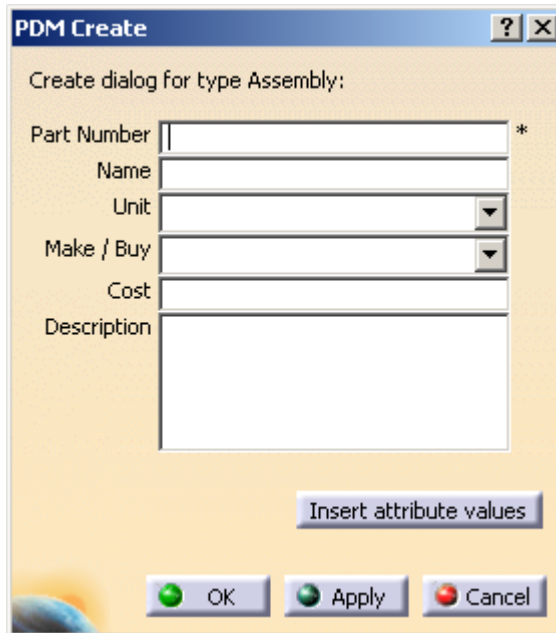

Picture 108: "Create" dialog for Assembly

When you click on the button "Insert attribute values" the attributes of the dialog will be filled (see *Picture 109: "Create" dialog for Assembly- Inserted attribute values*).

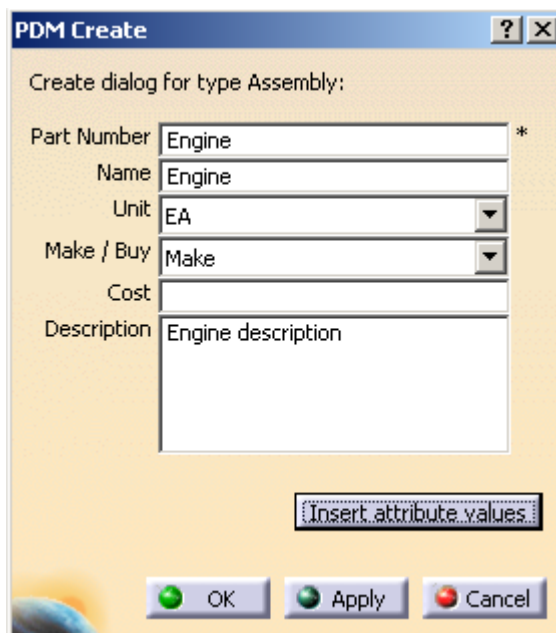

Picture 109: "Create" dialog for Assembly- Inserted attribute values

You can change the attribute values and start the create process by clicking on the "OK" button.

CATIA documents are set to read-only if corresponding PDM node is not modifiable

Loading a structure sets the corresponding CATIA files to read only (see *Picture 110: Save Management*).

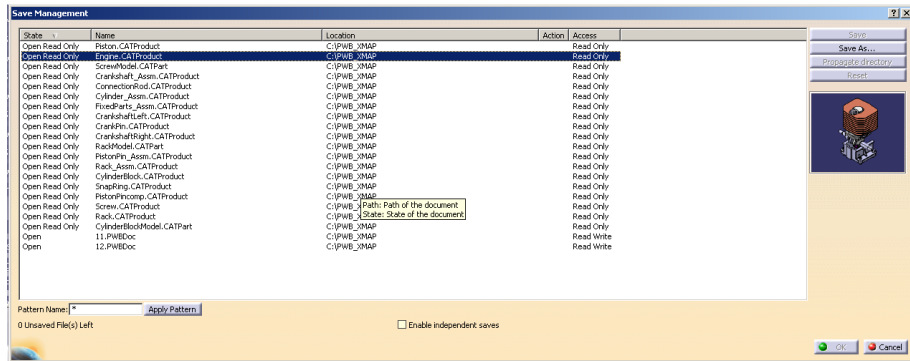

Picture 110: Save Management

Added check whether CATIA structure is valid before update

Before the structure will be created in the PDM system it will be checked if it is valid (see *Picture 111: Check if CATIA structure is valid*).

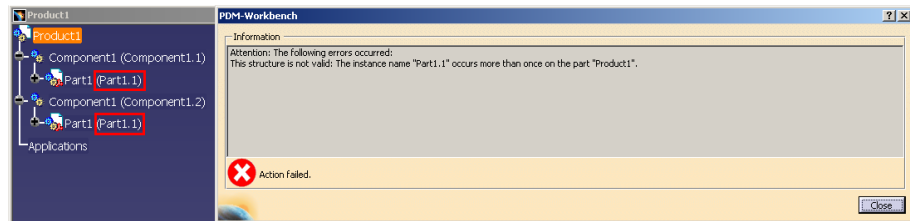

Picture 111: Check if CATIA structure is valid

Thumbnails

In the properties dialog for part and drawing documents a thumbnail will be shown.

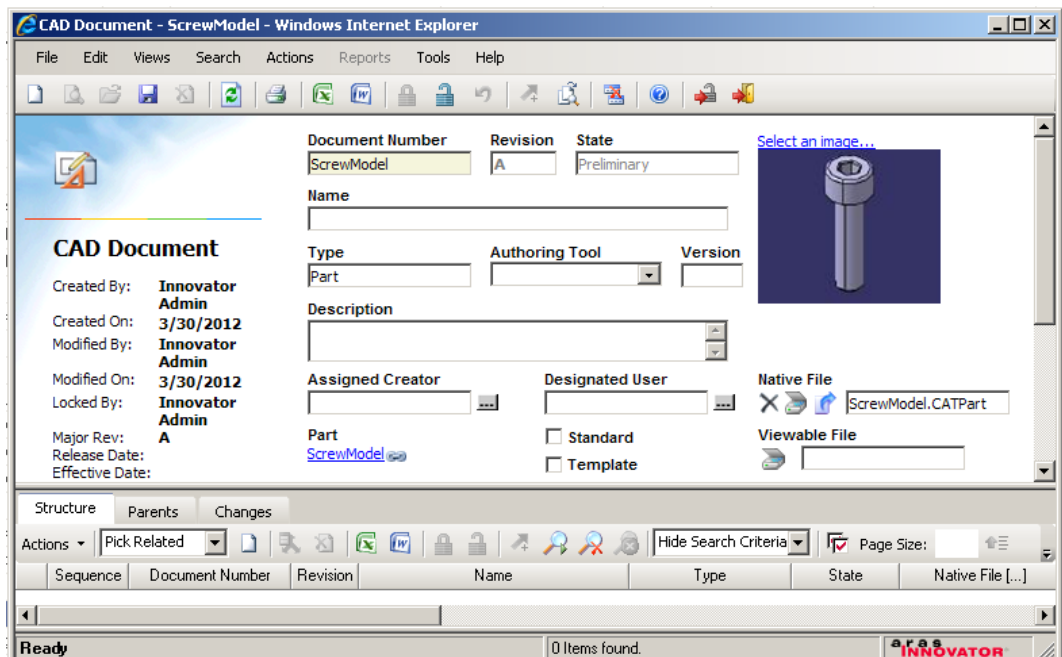

Picture 112: CAD Document properties in Aras Innovator

PDM Session Configuration

No configuration has to be set currently from CATIA for the Aras integration.

The configuration has to be made directly in the Aras Innovator application. For details please refer to the *PDM-Workbench Installation & Administration Manual*.

Logout

Once you finished your work in PDM-Workbench you do a Logout from the PDM system.

You select the “Logout” icon  within the PDM-Workbench toolbar (see *Picture 113: The PDM-Workbench toolbar after the login*) in CATIA V5 ...



Picture 113: The PDM-Workbench toolbar after the login

... and the session in the PDM system will be closed.

All PDM-Workbench windows get closed. Please consider that CATIA native windows resulting from a “Load” or “Open File” PDM-Workbench context action remain opened but that they are now out of synchronization with the PDM system. So we recommend you to close them, too.

Options

Once you are logged in into the PDM-Workbench you can set some options for the PDM-Workbench.

You open the options dialog with *Tools*→*Options* in CATIA V5. In the slider “PDM-Workbench” you can set the options for the PDM-Workbench (see *Picture 114: The PDM-Workbench options*).

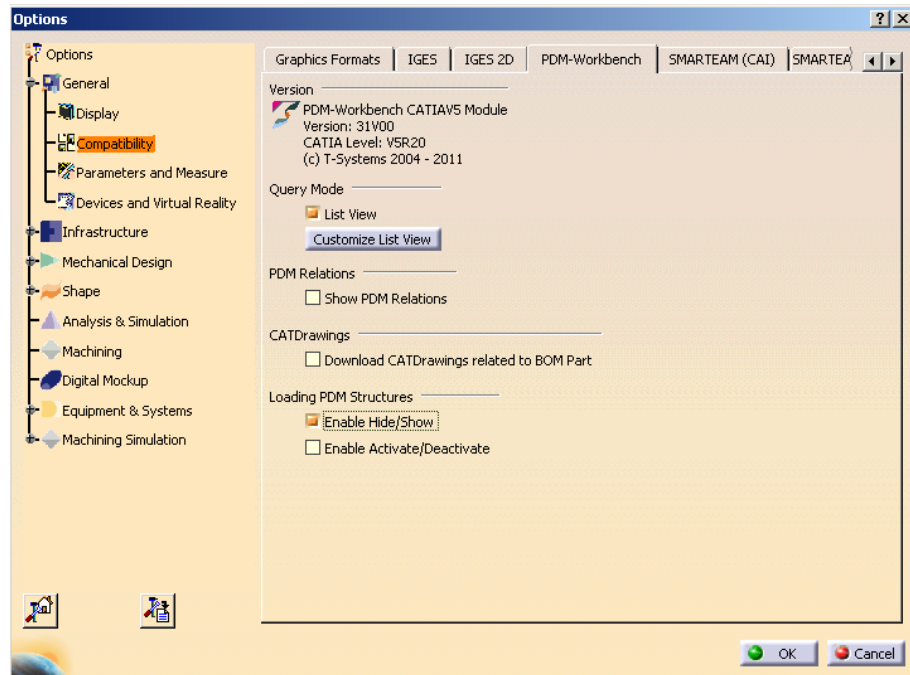

Picture 114: The PDM-Workbench options

Query Mode

When you set "List View" for the Query Mode the query result will be opened in a list view window.

You can customize the columns to be used in the list view window.

Please click "Customize List View" to open the "Customize List View" dialog (see *Picture 115: "Customize List View" dialog*).

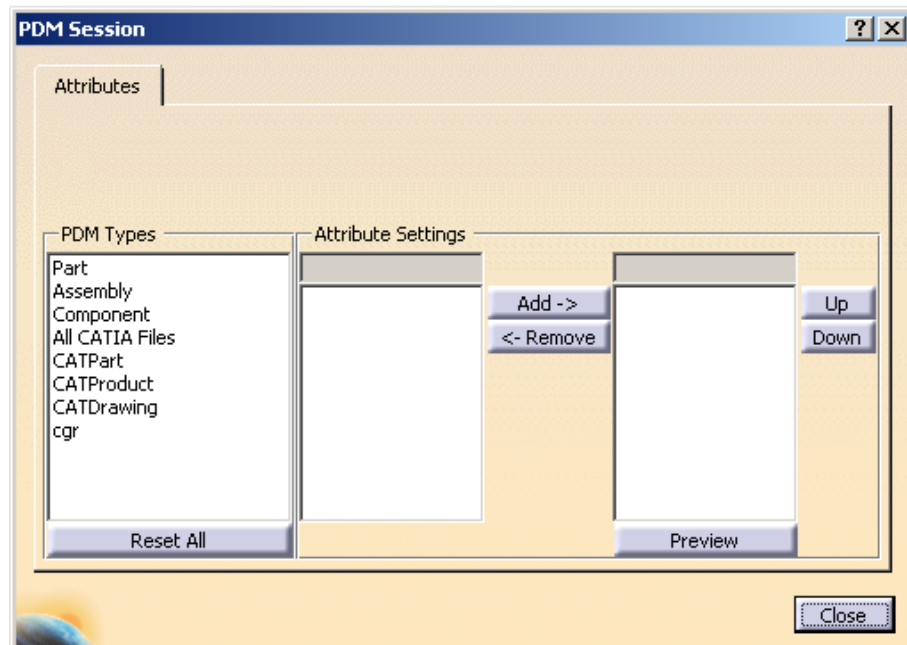

Picture 115: "Customize List View" dialog

When you are using a new PDM-Workbench Schema File then you have to reset the column settings by clicking on "Reset All".

In order to customize the columns for an object type you have to select the object type. In the example in *Picture 116: "Customize List View" dialog - for "Assembly"* the object type "Assembly" has been selected. In the right part of the dialog the attributes to be shown as columns are displayed. In the middle part of the dialog the attributes not to be shown as columns are displayed. In this case no attribute is hidden.

You can select an attribute on the right and remove it by clicking on the "Remove" button. Or you can select an attribute in the middle and by clicking on the "Add" button you can add it to the columns to be shown.

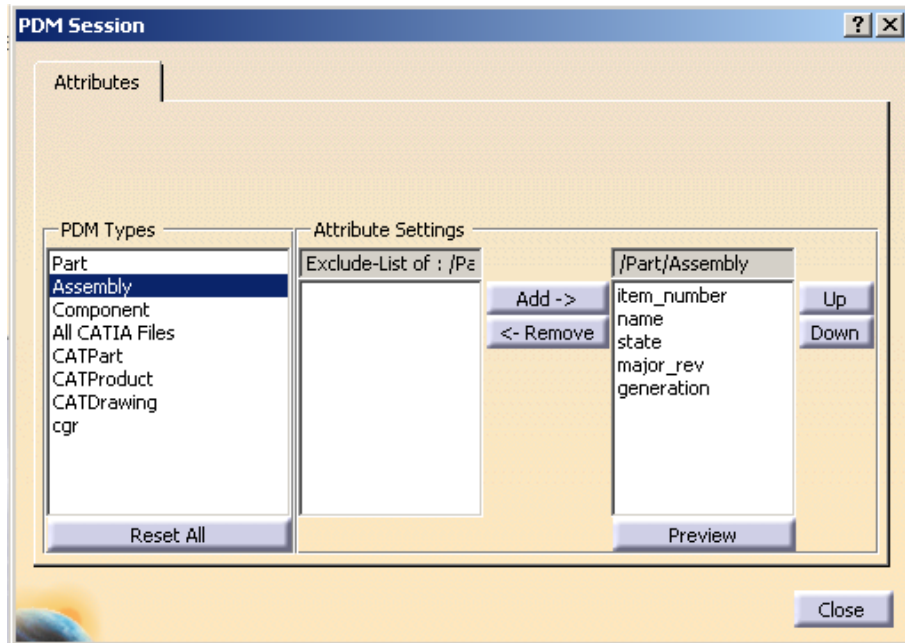

Picture 116: "Customize List View" dialog - for "Assembly"

By clicking on the "Preview" button you can see a preview of the list view (see *Picture 117: Preview of the "List View" dialog*).

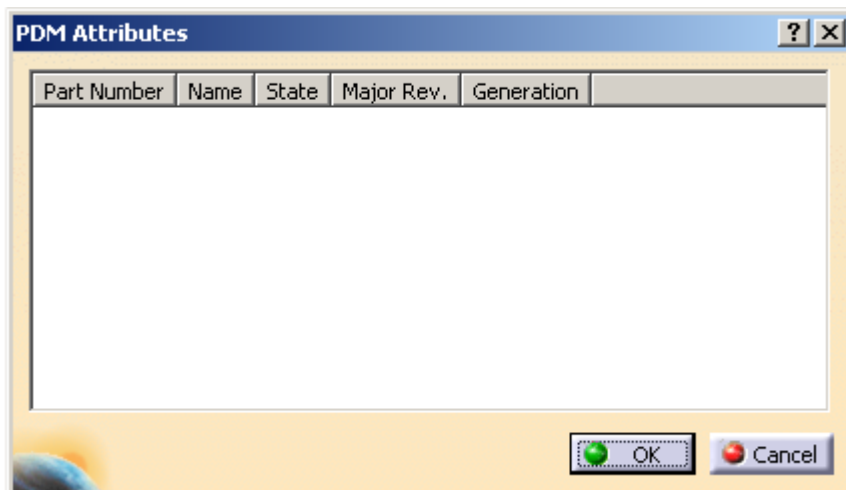

Picture 117: Preview of the "List View" dialog

PDM Relations

You have the possibility to hide or to show the PDM relations in the PDM product structure.

CATDrawings

CATDrawing files that are related to the root part of a part structure can be automatically downloaded when the part structure is loaded to CATIA.

Loading PDM Structures

When a PDM structure is loaded to CATIA sub-structures in the CATProduct tree can be hidden or deactivated if their corresponding PDM structures are not expanded.

Glossary

Unlock

Action withdrawing the right to update a work item. Normally this corresponds with publishing the work item to a larger number of people getting read access on this object.

Lock

Action giving the user the exclusive right to update a work item.

Context Menu

The menu that appears when the user selects an *icon* and holds the right mouse button pressed.

Dialog Window

Window in which the user enters information.

GII

Graphics Interactive Interface. The GII is a powerful programming tool, which completes the Open System Access to the CATIA environment.

Icon

Graphical representation of an *object*.

Object

An item or a relationship.

Query

To search the database for *objects* that match specific criteria.